

MICHELIN XDR2 S **IT WORKS AT YOUR SPEED.**



MORE UPTIME FOR YOUR TRUCK⁽¹⁾
+7% TIRE LIFE⁽¹⁾

(1) Compared to the MICHELIN 59/80 R 63 XDR S tire



MICHELIN

A better way forward

■ **MORE UPTIME FOR YOUR TRUCK⁽¹⁾**

■ **+7% TIRE LIFE⁽¹⁾**

BETTER BEAD AREA ENDURANCE

■ **Michelin B2 technology:** a 20% wider bead bundle and a better rim contact surface⁽¹⁾. It improves the **pressure distribution**, thus **reducing damages**.

■ **At 3 bar** the tire is already fitted properly⁽²⁾

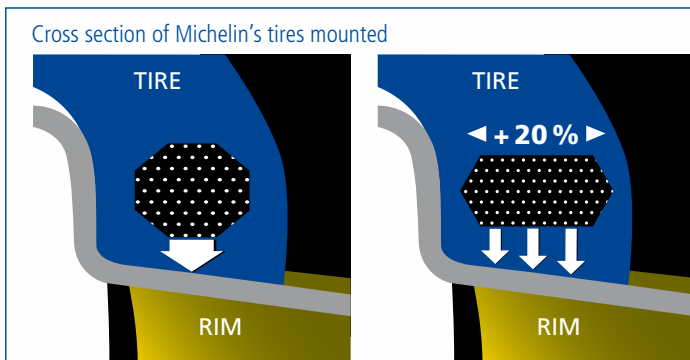

Standard bead

B2 technology bead

BETTER TREAD ENDURANCE

■ **A new tread pattern design**

Better crown protection:
46% larger central lug⁽¹⁾

Better thermal properties:
smaller tread blocks⁽¹⁾

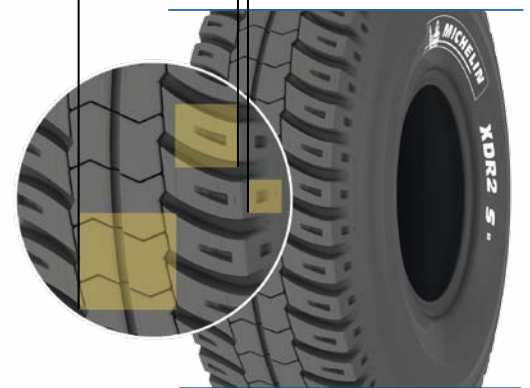

BETTER RESISTANCE TO AGGRESSIONS AND CORROSION

■ **New corrosion isolating cables design:** Encapsulated steel with rubber prevents extension of corrosion, which increase the tire life and facilitate repairs.



■ **New high resistance steel for stronger cables & plies**

+ 60% stronger steel cables to provide better shielding effect⁽¹⁾

New high tensile steel cables that provide more puncture resistant working plies.⁽¹⁾



MICHELIN XDR S

MICHELIN XDR2 S

MICHELIN 59/80 R 63 XDR2 S B E3 TL **
MICHELIN 59/80 R 63 XDR2 S C4 E3 TL **

CAI 532463
CAI 416409

(1) Compared to the MICHELIN 59/80 R 63 XDR S tire - (2) Internal mounting tests done at the Michelin's Almeria test center (2012) - Michelin RCS 855 200 507 Clermont Ferrand - Photos credits: Michelin, Thinkstock - Mai 2015