

# MICHELIN X-QUARRY



**Optimised productivity for your rigid dump trucks  
in all cycles and in total safety during quarry work**

**Productivity gains**

**Operating cost control**

**Safety**

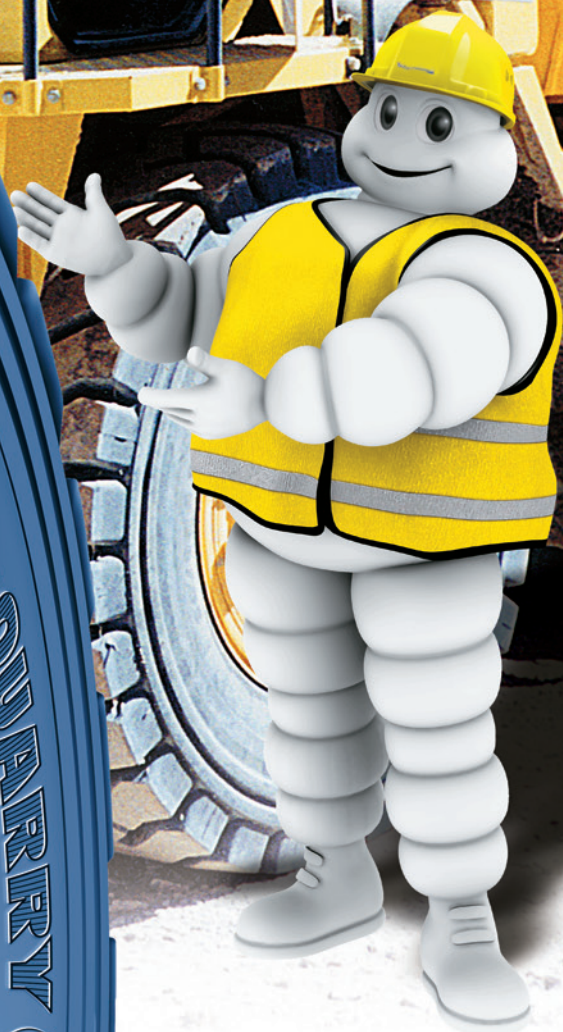

# MICHELIN X-QUARRY



Optimised productivity for your rigid dump trucks in all cycles and in total safety during quarry work

SIZES	TREAD DEPTH			
	mm	32 <sup>nd</sup> inch	TKPH	TMPH
16.00 R 25 E4R TL** (#)	48	61	93	64
18.00 R 33 E4R TL**	62	78.1	166	114
21.00 R 35 E4R TL**	68	86	220	151
24.00 R 35 E4R TL**	70	88.2	281	193

(#) in X-QUARRY

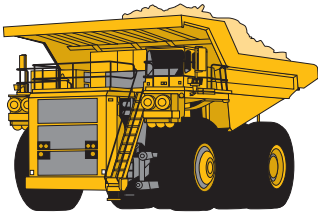

## ➤ PRODUCTIVITY GAINS AND OPERATING COST CONTROL

- Multipurpose tyre on cycles up to **19 km in an hour**, due to a new crown design, C2 technology + adapted under tread layer.
- Strong tyre with longer service life:
  - improved shock-absorption capacity (sidewall protection rib);
  - even wear;
  - wide tread pattern in the centre and squarer at the shoulders.
- Design and rubber mixes give full wear life in harshest conditions.

## ➤ SAFETY

- High traction potential on slippery surfaces. Makes machine easier to drive, reduces vibrations, provides excellent lateral grip and allows precise steering.
- Optimised tread pattern with an oblique design and a massive, continuous central tread.

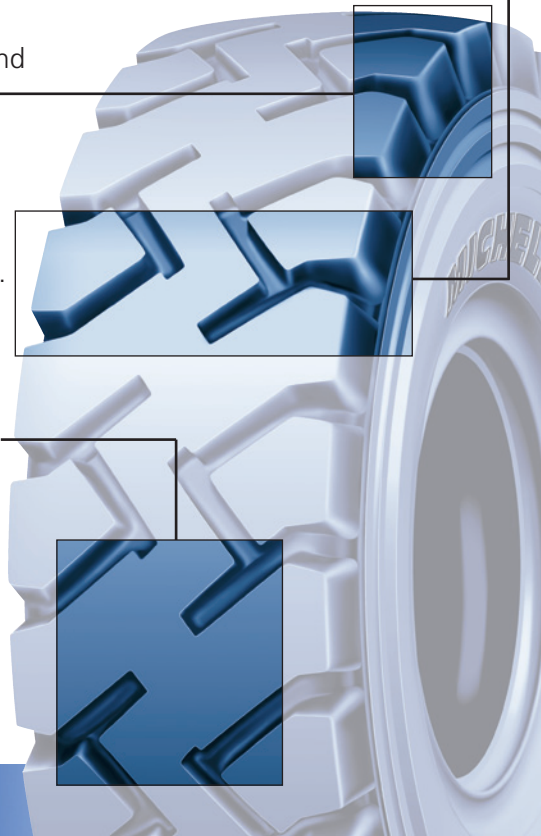

REPAIRABILITY AND RETREADABILITY MAXIMIZED THANKS TO THE EXTREME RELIABILITY OF THE CASING (##)

(##) provided that the worn tyre answers criteria of retreading and/or repair.

### BENEFITS OF THE MICHELIN® RADIAL TECHNIQUE

- longer tyre life
- better traction on all types of surface
- lower fuel consumption
- improved comfort
- increased resistance to punctures / flats
- increased heat resistance

