

DOCUMENTATION PROFESSIONNELLE DES PNEUMATIQUES **AGRICULTURE**

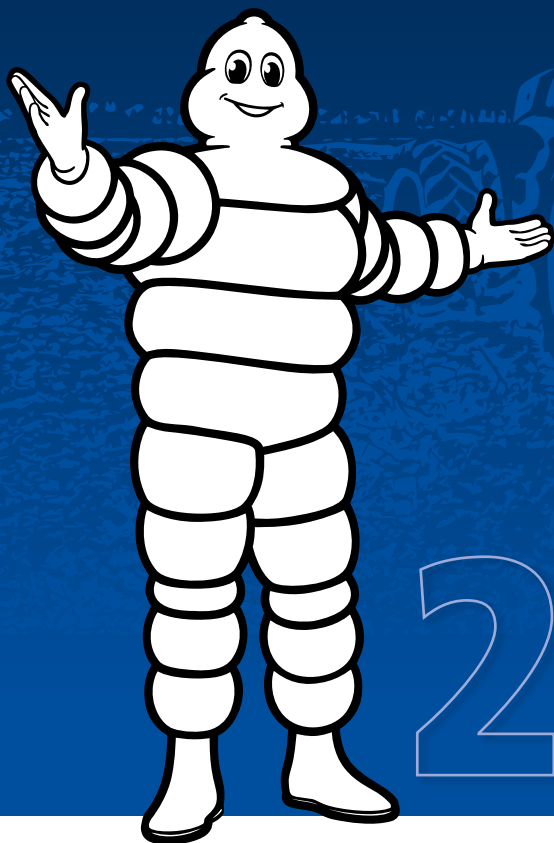

2021

MARS 2021

 [AGRO.MICHELIN.COM](https://www.agro.michelin.com)

 [@MICHELINAGRIFR](https://twitter.com/MICHELINAGRIFR)

 [MICHELIN AGRICULTURE](https://www.youtube.com/MICHELIN AGRICULTURE)

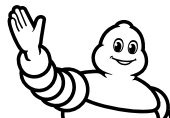

MICHELIN

GARANTIES COMMERCIALES



NOUVELLES GARANTIES COMMERCIALES*

en complément de toutes garanties légales
Les seules qui couvrent aussi vos machines équipées de télégonflage !



Fabrication

ANNÉE D'UTILISATION	PNEUS MICHELIN AGRICOLES	PNEUS MICHELIN COMPACT LINE
POURCENTAGE DU PNEU RESTANT À LA CHARGE DU CLIENT UTILISATEUR⁽¹⁾		
1 ^{RE}	Aucun frais. Pneu remplacé gratuitement ⁽²⁾ et frais de montage/déplacement à la charge de Michelin	
2 ^E	Aucun frais. Pneu remplacé gratuitement ⁽²⁾ et frais de montage/déplacement à la charge de Michelin	
3 ^E	30%	50%
4 ^E	40%	75%
5 ^E	50%	100%
6 ^E	60%	
7 ^E	70%	
8 ^E	80%	
9 ^E	90%	
10 ^E	100%	

Pour bénéficier des garanties commerciales ci-contre, consultez les modalités complètes sur <http://agricole.michelin.fr> ou contactez votre revendeur.

⁽¹⁾ Le montant du pneu restant à la charge du client utilisateur sera calculé sur la base d'un pourcentage défini, selon les indications des tableaux ci-dessus ou ci-contre, multiplié par le « prix de vente au détail » du pneu neuf en vigueur à la date du remplacement. L'ensemble des frais de montage, de déplacement et connexes seront à la charge du client.

⁽²⁾ Ce pneu devra être le même que le pneu démonté. Si ce pneu n'est plus disponible à la vente, il se sera remplacé par un pneu de même marque, de taille équivalente et de mêmes indices de charge et de vitesse. S'il n'existe plus de solution de substitution, contactez le Groupe Michelin pour plus de détails.



Dommages accidentels

Domage isolé, non répétitif, et non réparable - Pneumatique ne pouvant être maintenu en roulage

ANNÉE D'UTILISATION	PNEUS MICHELIN ULTRAFLEX TECHNOLOGIES	PNEUS MICHELIN AGRICOLES STANDARDS	PNEUS MICHELIN COMPACT LINE
POURCENTAGE DU PNEU RESTANT À LA CHARGE DU CLIENT UTILISATEUR⁽¹⁾			
1 ^{RE}	Aucun frais. Pneu remplacé gratuitement ⁽²⁾ et frais de montage/déplacement à la charge de Michelin	25%	Aucun frais. Pneu remplacé gratuitement ⁽²⁾ et frais de montage/déplacement à la charge de Michelin
2 ^E	25%	50%	100%
3 ^E	50%	75%	
4 ^E	75%	100%	
5 ^E	100%		



Spéciale usage Décapeuses (Scraper)⁽³⁾

ANNÉE D'UTILISATION	PNEUS MICHELIN AXIOBIB, MACHXBIB, MULTIBIB, OMNIBIB ET XM28
POURCENTAGE DU PNEU RESTANT À LA CHARGE DU CLIENT UTILISATEUR⁽¹⁾	
1 ^{RE}	25%
2 ^E	50%
3 ^E	75%
4 ^E	100%

⁽³⁾ Tracteur + benne équipée d'une lame pour décapage du sol et récupération des matériaux.

* pour les pneus MICHELIN AGRICOLE et COMPACT LINE.



Stubble (dommages dûs aux chaumes)

ANNÉE D'UTILISATION	PNEUS MICHELIN AVEC MARQUAGE STUBBLE SHIELD	PNEUS MICHELIN SANS MARQUAGE STUBBLE SHIELD
POURCENTAGE DU PNEU RESTANT À LA CHARGE DU CLIENT UTILISATEUR⁽¹⁾		
1 ^{RE}	Aucuns frais. Pneu remplacé gratuitement ⁽²⁾ et frais de montage/déplacement à la charge de Michelin	25%
2 ^E	25%	50%
3 ^E	50%	75%
4 ^E	75%	100%
5 ^E	100%	

SOMMAIRE

GARANTIES COMMERCIALES	2
LIRE LES DONNÉES TECHNIQUES	4
ÉQUIVALENCES DIMENSIONNELLES	5
PNEUMATIQUES PAR TAILLES	7
CIRCONFÉRENCES DE ROULEMENT	12
INDICES DE CHARGE	20
NOUVEAUX TABLEAUX CHARGES/PRESSIONS	21
ZEN@TERRA	22
MICHELIN ULTRAFLEX TECHNOLOGIES	23
Liste des pneus dont la fabrication a été arrêtée	24

TRACTEURS 25

MICHELIN EVOBIB	25
MICHELIN ROADBIB	27
MICHELIN AXIOBIB 2	31
MICHELIN AXIOBIB	38
MICHELIN MACHXBIB	44
MICHELIN XEOBIB	52
MICHELIN MULTIBIB	56
MICHELIN OMNIBIB	64
MICHELIN YELDBIB	71
MICHELIN AGRIBIB 2	75
MICHELIN AGRIBIB	83

RÉCOLTE 96

MICHELIN CEREXBIB 2	96
MICHELIN CEREXBIB	102
MICHELIN FLOATXBIB	107
MICHELIN MEGAXBIB 2	110
MICHELIN MEGAXBIB	115

TRAITEMENT 122

MICHELIN SPRAYBIB	122
MICHELIN AGRIBIB ROW CROP	126

TRANSPORT 131

MICHELIN TRAILXBIB	131
MICHELIN CARGOXBIB HIGH FLOTATION	135
MICHELIN CARGOXBIB HEAVY DUTY	140
MICHELIN CARGOXBIB	142
MICHELIN XP 27	145
MICHELIN XS	147

COMPACT LINE 149

MICHELIN XMCL	149
MICHELIN BIBLOAD HARD SURFACE	156
MICHELIN CROSSGRIP	161
MICHELIN XF	166
MICHELIN XM 47	168
MICHELIN BIBSTEEL ALL TERRAIN	171
MICHELIN BIBSTEEL HARD SURFACE	174
MICHELIN POWER CL	176
ÉQUIVALENCES DIMENSIONNELLES	182
GAMMES PAR USAGES	184

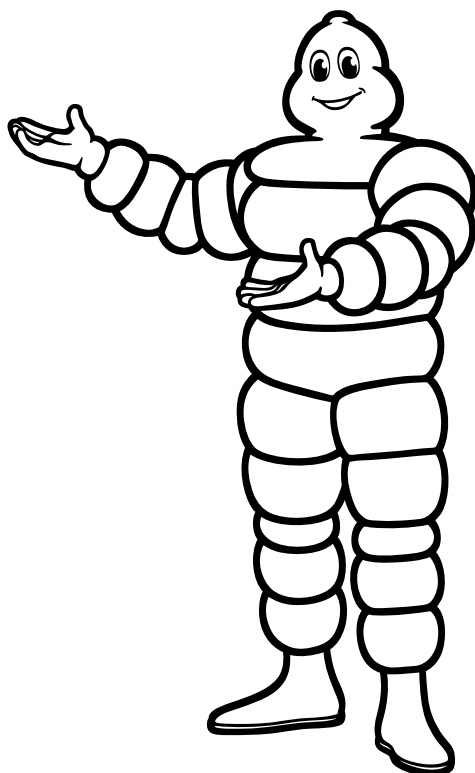

LIRE LES DONNÉES TECHNIQUES

Ø pouces	Description	CAI	e mm	D mm	R' mm	Cdr. mm	Jante(s) recommandée(s)	Jante(s) tolérée(s)	Chambre à air (Code)	Volume interne 75% (litres)	Profond. de sculpture (mm)
30	VF 540/65 R30 158D/155E TL	296638	536	1460	641	4316	W18L	W16L (NRO)	754	332	48

(TL) Tubeless
(IND) Industrial

Un marquage spécifique pour des pneus de très haute technologie

- **IF : Improved Flexion**
(Pneus conçus pour porter 20% de charge en plus à la même pression)
- **VF : Very High Flexion**
(Pneus conçus pour porter 40% de charge en plus à la même pression)
- **CFO** : Pneus conçus pour des conditions cycliques de charge
- **CFO+** : Cyclic Field Operation autorisant un bonus pour charge cyclique au champ sur une distance de 1,5km maximum

	Échelle pression exprimée en bar et psi														
Bar	0,40	0,60	0,80	0,90	1,00	1,10	1,20	1,30	1,40	1,50	1,60	1,70	1,80	1,90	2,00
Psi	6	9	12	13	15	16	17	19	20	22	23	25	26	28	29
65 km/h		2180	2500	2690	2875	3065	3250	3405	3565	3720	3875	3970	4065	4155	4250
70 km/h		2000	2295	2470	2640	2815	2985	3130	3270	3415	3555	3640	3730	3815	3900
65 km/h Dual		1920	2180	2310	2440	2570	2700	2830	2960	3090	3220	3350	3480	3610	3740

Vitesse d'usage en km/h

Charge par pneu exprimée en kg



A la fin des pages des données techniques de chaque gamme, figurent des annotations importantes pour l'utilisation des pneumatiques

ÉQUIVALENCES DIMENSIONNELLES

ÉTAPE 1

Déterminer le SRI correspondant à partir de la dimension d'origine.

Speed Radius Index (SRI) est un paramètre utilisé pour le calcul de la vitesse théorique des véhicules lors des procédures d'homologation dans l'Union Européenne et pour l'interchangeabilité des différentes dimensions de pneus.

Ø	DIMENSIONS	SRI	Ø	DIMENSIONS	SRI	Ø	DIMENSIONS	SRI	Ø	DIMENSIONS	SRI	
16	6.50R16	360	26	480/70R26	650	32	210/95R32 (8.3R32)	575	38	650/85R38	975	
	7.50R16	390		23.1-26	750		230/95R32 (9.5R32)	600		680/75R38	925	
	250/80R16	390		520/80R26	700		270/95R32 (11.2R32)	625		710/60R38	875	
	260/70R16	360		540/65R26	650		320/85R32 (12.4R32)	650		710/70R38	925	
	280/65R16	360		580/70R26	675		650/75R32 (24.5R32)	825		710/85R38	1025	
	280/70R16	390		620/70R26	725		680/75R32 (30.5LR32)	825		750/65R38	925	
18	320/65R16	390	28	620/75R26	750	34	680/85R32	975	42	800/70R38	975	
	7.50R18	410		750/50R26	675		800/65R32	875		900/60R38	975	
	280/70R18	410		750/65R26	750		800/70R32	925		40	230/95R40 (9.5R40)	700
	320/65R18	410		9.5R28	550		900/60R32	925			270/95R42 (11.2R42)	750
	340/65R18	425		250/85R28	550		1000/55R32	875			300/95R42 (12.4R42)	800
	20	7.50R20		425	280/85R28 (11.2R28)		575	1050/50R32			875	320/90R42
9.5R20		450	320/70R28	575	320/85R34	675	480/80R42 (18.4R42)	875				
11.2R20		475	320/85R28 (12.4R28)	600	380/85R34	725	520/85R42 (20.8R42)	925				
12.4R20		500	340/65R28	550	420/85R34 (16.9R34)	750	580/85R42	975				
13.6R20		525	340/85R28 (13.6R28)	625	440/80R34	750	620/70R42	925				
14.9LR20		525	360/70R28	600	460/85R34 (18.4R34)	775	650/65R42	925				
24	260/80R20	450	30	380/70R28	625	36	480/70R34	750	44	650/85R42	1025	
	280/70R20	425		380/85R28 (14.9R28)	650		480/80R34	775		710/60R42	925	
	280/85R20	475		420/65R28	600		520/70R34	775		710/70R42	975	
	300/70R20	450		420/70R28	650		520/75R34	775		710/75R42	1025	
	320/70R20	475		420/75R28	650		540/65R34	750		900/50R42	925	
	320/85R20	500		420/85R28 (16.9R28)	675		600/60R34	750		900/60R42	1025	
25	340/65R20	450	32	440/65R28	625	38	600/65R34	775	46	210/95R44 (8.3R44)	725	
	340/75R20	500		480/60R28	625		620/75R34	825		230/95R44 (9.5R44)	750	
	360/70R20	500		480/65R28	650		650/60R34	775		270/95R44 (11.2R44)	775	
	380/70R20	525		480/70R28	675		650/65R34	825		750/70R44	1025	
	380/75R20	525		520/60R28	650		650/75R34	875		270/95R46 (11.2R46)	800	
	420/65R20	500		540/65R28	675		710/60R34	825		300/95R46 (12.4R46)	825	
28	440/65R20	525	34	600/60R28	675	40	710/75R34	925	48	320/90R46	825	
	8.3R24	475		600/65R28	700		210/95R36 (8.3R36)	625		340/85R46 (13.6R46)	825	
	250/85R24 (9.5R24)	500		600/70R28	725		230/95R36 (9.5R36)	650		380/90R46	875	
	280/85R24 (11.2R24)	525		380/85R30 (14.9R30)	675		270/95R36 (11.2R36)	675		420/80R46	875	
	300/70R24	500		420/70R30	675		320/85R36 (12.4R36)	700		480/80R46	925	
	320/70R24	525		420/85R30 (16.9R30)	700		340/85R36 (13.6R36)	725		520/85R46 (20.8R46)	975	
30	320/85R24 (12.4R24)	550	36	420/90R30	725	42	270/95R38 (11.2R38)	700	50	620/70R46	975	
	340/85R24 (13.6R24)	575		460/85R30 (18.4R30)	725		320/85R38 (12.4R38)	725		750/75R46	≥ 1075	
	360/70R24	550		480/70R30	700		340/85R38 (13.6R38)	750		900/65R46	≥ 1075	
	360/80R24	575		480/75R30	700		380/80R38	750		230/95R48 (9.5R48)	800	
	380/70R24	575		520/70R30	725		380/95R38	800		270/95R48 (11.2R48)	825	
	380/85R24 (14.9R24)	600		520/85R30	775		400/75R38 (15.5R38)	750		340/85R48 (13.6R48)	875	
32	400/70R24	575	38	540/65R30	700	44	420/85R38 (16.9R38)	800	52	320/90R50	875	
	420/65R24	550		600/60R30	700		460/85R38 (18.4R38)	825		380/90R50	925	
	420/70R24	600		600/65R30	725		480/70R38	800		420/95R50	975	
	420/85R24 (16.9R24)	625		600/70R30	750		520/70R38	825		480/80R50	975	
	440/65R24	575		620/70R30	775		520/85R38 (20.8R38)	875		480/95R50	1025	
	460/70R24	600		620/75R30	800		540/65R38	800		54	300/95R52 (12.4R52)	925
480/65R24	600	650/70R30	800	540/80R38	875	270/95R54 (11.2R54)	925					
480/70R24	625	650/75R30	800	600/60R38	800	320/90R54	925					
500/70R24	625	710/55R30	725	600/65R38	825	380/90R54	975					
540/65R24	625	710/60R30	750	650/60R38	825							
1000/50R25	750			580/70R38	875							
				620/70R38	875							
				650/65R38	875							
				650/75R38	925							

ÉQUIVALENCES DIMENSIONNELLES

ÉTAPE 2

A partir du SRI obtenu, déterminer les équivalences dimensionnelles possibles.

IMPORTANT :

- En aucun cas le SRI ne correspond à une valeur précise de la circonférence de roulement. Il n'est utilisé dans ces tableaux qu'à titre indicatif. Une vérification par mesure est nécessaire.
- Toute transformation nécessite de calculer le rapport de pont et d'évaluer le taux de prépondérance, de vérifier que les largeurs et les diamètres des jantes sont compatibles (voir pages techniques).

SRI	ÉQUIVALENCES
360	6.50R16
	260/70R16
	280/65R16
390	7.50R16
	250/80R16
	280/70R16
410	320/65R16
	7.50R18
	280/70R18
425	320/65R18
	7.50R20
	280/70R20
450	340/65R18
	9.5R20
	260/80R20
475	300/70R20
	340/65R20
	11.2R20
500	280/85R20
	320/70R20
	8.3R24
525	250/85R24 // 9.5R24
	300/70R24
	320/85R20 // 12.4R24
550	340/75R20
	360/70R20
	420/65R20
575	280/85R24 // 11.2R24
	320/70R24
	380/70R20
600	380/75R20 // 13.6R20
	14.9LR20
	440/65R20
625	250/85R28 // 9.5R28
	320/85R24 // 12.4R24
	340/65R28
650	360/70R24
	420/65R24
	210/95R32 // 8.3R32
675	280/85R28 // 11.2R28
	320/70R28
	340/85R24 // 13.6R24
700	360/80R24
	380/70R24
	400/70R24
725	440/65R24
	230/95R32 // 9.5R32
	320/85R28 // 12.4R28
750	360/70R28
	380/85R24 // 14.9R24
	420/65R28
775	420/70R24
	460/60R28
	500/70R24
800	540/65R24
	540/65R26
	230/95R36 // 9.5R36
825	320/85R32 // 12.4R32
	380/85R28 // 14.9R28
	420/70R28
850	480/60R28
	420/75R28
	480/65R28
875	480/70R26
	520/60R28
	520/65R26
900	540/65R28
	540/65R30
	1000/50R25
925	270/95R44 // 11.2R44
	460/85R34 // 18.4R34
	480/80R34
950	520/85R30
	520/70R34
	520/75R34
975	600/65R34
	620/70R30
	650/60R34
1000	230/95R48 // 9.5R48
	270/95R46 // 11.2R46
	300/95R42 // 12.4R42
1025	320/90R42
	380/95R38
	420/85R38 // 16.9R38
1050	480/70R38
	540/65R38
	600/60R38
1075	620/75R30
	650/70R30
	650/75R30
1100	270/95R48 // 11.2R48
	300/95R46 // 12.4R46
	320/90R46
1125	340/85R46 // 13.6R46
	460/85R38 // 18.4R38
	520/70R38
1150	620/75R32 // 24.5R32
	650/65R34
	650/60R38
1175	710/60R34
	270/95R54 // 11.2R54
	300/95R52 // 12.4R52
1200	320/90R54
	380/90R50
	480/80R46
1225	520/85R42 // 20.8R42
	620/70R42
	650/65R42
1250	650/75R38
	680/75R38
	680/85R32
1275	710/60R42
	710/70R38
	710/75R34
1300	750/65R38
	800/70R32
	900/50R42
1325	900/60R32
	380/90R54
	420/95R50
1350	480/80R50
	520/85R46 // 20.8R46
	580/85R42
1375	620/70R46
	650/85R38
	710/70R42
1400	800/70R38
	900/60R38
	480/95R50
1425	650/85R42
	650/85R42
	710/75R42
1450	710/85R38
	750/70R44
	900/60R42
1475	900/65R46
	750/75R46
	900/65R46

SRI	ÉQUIVALENCES
625	210/95R36 // 8.3R36
	270/95R32 // 11.2R32
	340/85R28 // 13.6R28
650	380/70R28
	420/85R24 // 16.9R24
	440/65R28
675	480/60R28
	480/70R24
	500/70R24
700	540/65R24
	230/95R36 // 9.5R36
	320/85R32 // 12.4R32
725	380/85R28 // 14.9R28
	420/70R28
	420/75R28
750	480/65R28
	480/70R26
	520/60R28
775	540/65R26
	270/95R36 // 11.2R36
	320/85R34 // 12.4R34
800	380/85R30 // 14.9R30
	420/70R30
	420/85R28 // 16.9R28
825	480/70R28
	540/65R28
	580/70R26
850	600/60R28
	750/50R26
	230/95R40 // 9.5R40
875	320/95R38 // 11.2R38
	370/95R36 // 12.4R36
	420/85R30 // 16.9R30
900	480/70R30
	480/75R30
	520/80R26
925	540/65R30
	600/60R30
	600/65R28
950	210/95R44 // 8.3R44
	320/85R38 // 12.4R38
	340/85R36
975	380/85R34
	420/90R30
	460/85R30 // 18.4R30
1000	520/70R30
	600/65R30
	600/70R28
1025	620/70R26
	710/55R30
	230/95R44 // 9.5R44
1050	270/95R42 // 11.2R42
	340/85R38 // 13.6R38
	380/80R38
1075	400/75R38
	420/85R34 // 16.9R34
	440/80R34
1100	480/70R34
	540/65R34
	600/60R34
1125	600/70R30
	650/75R30
	270/95R44 // 11.2R44
1150	460/85R34 // 18.4R34
	480/80R34
	520/85R30
1175	520/70R34
	520/75R34
	600/65R34
1200	620/70R30
	650/60R34
	230/95R48 // 9.5R48
1225	270/95R46 // 11.2R46
	300/95R42 // 12.4R42
	320/90R42
1250	380/95R38
	420/85R38 // 16.9R38
	480/70R38
1275	540/65R38
	600/60R38
	620/75R30
1300	650/70R30
	650/75R30
	270/95R48 // 11.2R48
1325	300/95R46 // 12.4R46
	320/90R46
	340/85R46 // 13.6R46
1350	460/85R38 // 18.4R38
	520/70R38
	620/75R32 // 24.5R32
1375	650/65R34
	650/60R38
	710/60R34

SRI	ÉQUIVALENCES
750	230/95R44 // 9.5R44
	270/95R42 // 11.2R42
	340/85R38 // 13.6R38
825	380/80R38
	400/75R38 // 15.5R38
	420/85R34 // 16.9R34
875	440/80R34
	480/70R34
	540/65R34
925	600/60R34
	600/70R30
	620/75R26 // 23.1R26
975	710/60R30
	750/65R26
	1000/50R25
1025	270/95R44 // 11.2R44
	460/85R34 // 18.4R34
	480/80R34
1075	520/85R30
	520/70R34
	520/75R34
1125	600/65R34
	620/70R30
	650/60R34
1175	230/95R48 // 9.5R48
	270/95R46 // 11.2R46
	300/95R42 // 12.4R42
1225	320/90R42
	380/95R38
	420/85R38 // 16.9R38
1275	480/70R38
	540/65R38
	600/60R38
1325	620/75R30
	650/70R30
	650/75R30
1375	270/95R48 // 11.2R48
	300/95R46 // 12.4R46
	320/90R46
1425	340/85R46 // 13.6R46
	460/85R38 // 18.4R38
	520/70R38
1475	620/75R32 // 24.5R32
	650/65R34
	650/60R38
1525	710/60R34
	270/95R54 // 11.2R54
	300/95R52 // 12.4R52
1575	320/90R54
	380/90R50
	480/80R46
1625	520/85R42 // 20.8R42
	620/70R42
	650/65R42
1675	650/75R38
	680/75R38
	680/85R32
1725	710/60R42
	710/70R38
	710/75R34
1775	750/65R38
	800/70R32
	900/50R42
1825	900/60R32
	380/90R54
	420/95R50
1875	480/80R50
	520/85R46 // 20.8R46
	580/85R42
1925	620/70R46
	650/85R38
	710/70R42
1975	800/70R38
	900/60R38
	480/95R50
2025	650/85R42
	650/85R42
	710/75R42
2075	710/85R38
	750/70R44
	900/60R42
2125	900/65R46
	750/75R46
	900/65R46

SRI	ÉQUIVALENCES
360	320/90R50
	340/85R48 // 13.6R48
	380/90R46
390	420/80R46
	480/80R42 // 18.4R42
	520/85R38 // 20.8R38
410	540/80R38
	580/70R38
	620/70R38
425	650/65R38
	650/75R34
	680/75R32 // 30.5LR32
450	710/60R38
	800/65R32
	1000/55R32
475	1050/50R32
	270/95R54 // 11.2R54
	300/95R52 // 12.4R52
500	320/90R54
	380/90R50
	480/80R46
525	520/85R42 // 20.8R42
	620/70R42
	650/65R42
550	650/75R38
	680/75R38
	680/85R32
575	710/60R42
	710/70R38
	710/75R34
600	750/65R38
	800/70R32
	900/50R42
625	900/60R32
	380/90R54
	420/95R50
650	480/80R50
	520/85R46 // 20.8R46
	580/85R42
675	620/70R46
	650/85R38
	710/70R42
700	800/70R38
	900/60R38
	480/95R50
725	650/85R42
	650/85R42
	710/75R42
750	710/85R38
	750/70R44
	900/60R42
775	900/65R46
	750/75R46
	900/65R46

PNEUMATIQUES PAR TAILLES

DIAM	DIMENSION	EVOBIB	ROADBIB	AXIOBIB	AXIOBIB 2	MACHXBIB	XEOBIB	MULTIBIB	OMNIBIB	YIELDIBIB	AGRIBIB	AGRIBIB 2	AGRIBIB RC	CEREXBIB	CEREXBIB 2	FLOATXBIB	MEGAXBIB	MEGAXBIB 2	SPRAXBIB	TRAILXBIB	CARGOXBIB	CARGOXBIB HF	CARGOXBIB 2	CARGOXBIB HD	X P27	XS	
16	270/65 R16																								S		
16	280/70 R16								S																		
16	320/65 R16							S																			
18	270/65 R18																									S	
18	320/65 R18							S																			
18	340/65 R18							S																		S	
20	280/70 R20								S																		
20	420/65 R20							S																			
20	440/65 R20							S																			
20.5	24/70 R20.5																										S
22.5	500/60 R22.5																				VF			S			
22.5	560/45 R22.5																				VF			S			
22.5	560/60 R22.5																				VF			S			
22.5	600/50 R22.5																				VF	S		S			
22.5	710/45 R22.5																				VF		S				
24	9.5 R24										S																
24	11.2 R24									S																	
24	12.4 R24									S																	
24	13.6 R24									S																	
24	14.9 R24									S																	
24	16.9 R24									S																	
24	320/70 R24								S																		
24	360/70 R24								S																		
24	380/70 R24								S																		
24	420/65 R24							S																			
24	420/70 R24								S																		
24	440/65 R24							S																			
24	480/65 R24							S																			
24	480/70 R24								S																		
24	540/65 R24							S																			
25	1000/50 R25															VF	S										
26	28LR26																									S	
26	480/80 R26									S																	
26	520/80 R26														VF												
26	620/70 R26														VF												
26	620/75 R26																S										

PNEUMATIQUES PAR TAILLES

DIAM	DIMENSION	EVOBIB	ROADBIB	AXIOBIB	AXIOBIB 2	MACFXBIB	XEOBIB	MULTIBIB	OMNIBIB	YELDBIB	AGRIBIB	AGRIBIB 2	AGRIBIB RC	CEREXBIB	CEREXBIB 2	FLOATXBIB	MEGAXBIB	MEGAXBIB 2	SPRANBIB	TRAILXBIB	CARGOXBIB	CARGOXBIB HF	CARGOXBIB 2	CARGOXBIB HD	XPZT	XS	
26	750/50 R26															VF		S									
26	750/65 R26														VF		S										
26.5	600/55 R26.5																				VF		VF				
26.5	650/55 R26.5																				VF		VF				
26.5	710/50 R26.5																				VF		VF				
26.5	800/45 R26.5																						S				
28	12.4 R28											S															
28	13.6 R28											S															
28	14.9 R28											S															
28	16.9 R28											S															
28	280/85 R28											S															
28	380/70 R28								S																		
28	420/65 R28							S																			
28	420/70 R28								S																		
28	420/85 R28											S															
28	440/65 R28							S																			
28	480/60 R28						VF																				
28	480/65 R28							S																			
28	480/70 R28								S																		
28	520/60 R28						VF																				
28	540/65 R28							S																			
28	600/60 R28						VF																				
28	600/65 R28					S																					
28	600/70 R28					S																					
30	16.9 R30											S															
30	18.4 R30											S															
30	380/85 R30											S															
30	420/85 R30											S															
30	420/90 R30											S															
30	480/70 R30								S																		
30	520/85 R30														VF												
30	540/65 R30		S		VF			S																			
30	600/60 R30				VF		VF																				
30	600/70 R30	VF	S	IF	VF	S																					
30	620/70 R30														VF												
30	620/75 R30				IF	VF																			S		
30	650/75 R30				IF																						

PNEUMATIQUES PAR TAILLES

DIAM	DIMENSION	EVOBIB	ROADBIB	AXIOBIB	AXIOBIB 2	MACFXBIB	XEOBIB	MULTIBIB	OMNIBIB	YELDBIB	AGRIBIB	AGRIBIB 2	AGRIBIB RC	CEREXBIB	CEREXBIB 2	FLOATXBIB	MEGAXBIB	MEGAXBIB 2	SPRAXBIB	TRAILXBIB	CARGOXBIB	CARGOXBIB HF	CARGOXBIB 2	CARGOXBIB HD	XPZ7	XS
30	710/55 R30					S																				
30	710/65 R30														VF											
30.5	600/60 R30.5																				S					
30.5	650/65 R30.5																			VF		S				
30.5	710/50 R30.5																					S				
30.5	750/60 R30.5																			VF		VF				
30.5	800/45 R30.5																					S				
30.5	850/50 R30.5																					S				
32	650/75 R32										S						S	S								
32	680/85 R32													IF												
32	800/60 R32																						S			
32	800/65 R32														IF			S								
32	800/70 R32														IF		S	S								
32	900/60 R32														VF			S								
32	1000/55 R32													IF		IFVF										
32	1050/50 R32																S	S								
34	18.4 R34										S															
34	320/85 R34											S														
34	380/85 R34									VF		S														
34	420/85 R34									VF																
34	420/85 R34											S														
34	480/70 R34			IF				S																		
34	500/85 R34														VF											
34	520/70 R34							S																		
34	540/65 R34							S																		
34	600/60 R34						VF																			
34	600/65 R34							S																		
34	620/75 R34																S									
34	650/60 R34	S	IF	VF	S																					
34	650/65 R34	S	IF	VF	S																					
34	710/60 R34			IF	VF																					
34	710/75 R34																S	S								
36	12.4 R36										S															
38	12.4 R38										S															
38	13.6 R38										S															
38	18.4 R38										S															
38	20.8 R38										S															

PNEUMATIQUES PAR TAILLES

DIAM	DIMENSION	EVOBIB	ROADBIB	AXIOBIB	AXIOBIB 2	MACFXBIB	XEOBIB	MULTIBIB	OMNIBIB	YELDBIB	AGRIBIB	AGRIBIB 2	AGRIBIB RC	CEREXBIB	CEREXBIB 2	FLOATXBIB	MEGAXBIB	MEGAXBIB 2	SPRANBIB	TRAILXBIB	CARGOXBIB	CARGOXBIB HF	CARGOXBIB 2	CARGOXBIB HD	XPZT	XS
38	320/85 R38												SIF													
38	380/80 R38									VF	S								VF							
38	380/95 R38									VF	S															
38	420/85 R38											S														
38	480/70 R38							S																		
38	520/70 R38							S																		
38	520/85 R38											S														
38	540/65 R38							S																		
38	580/70 R38							S																		
38	600/60 R38						VF																			
38	600/65 R38							S																		
38	620/70 R38																S	S								
38	650/60 R38				VF		VF																			
38	650/65 R38			IF				S																		
38	650/75 R38					S																				
38	650/85 R38			IF	VF	S											S									
38	680/75 R38													IF												
38	680/80 R38														IF											
38	710/60 R38			IF			VF																			
38	710/70 R38					S																				
38	710/85 R38			IF																						
38	800/70 R38			IF	VF	S									IF											
38	900/60 R38														VF	VF										
42	320/90 R42												SIF							VF						
42	480/80 R42											S								VF						
42	520/85 R42											S			VF		S									
42	580/85 R42														VF											
42	620/70 R42							S									S									
42	650/60 R42						VF																			
42	650/65 R42		S		VF			S																		
42	650/85 R42				VF																					
42	710/60 R42				VF		VF																			
42	710/70 R42	VF	S	IF	VF	S									VF											
42	710/75 R42		S	IF	VF	S																				
42	800/70 R42															IF										
42	900/50 R42					S																				
42	900/60 R42			IF	VF											VF										

PNEUMATIQUES PAR TAILLES

DIAM	DIMENSION	EVOBIB	ROADBIB	AXIOBIB	AXIOBIB 2	MACFXBIB	XEOBIB	MULTIBIB	OMNIBIB	YELDBIB	AGRIBIB	AGRIBIB 2	AGRIBIB RC	CEREXBIB	CEREXBIB 2	FLOATXBIB	MEGAXBIB	MEGAXBIB 2	SPRANBIB	TRAILXBIB	CARGOXBIB	CARGOXBIB HF	CARGOXBIB 2	CARGOXBIB HD	XPZ7	XS
44	750/70 R44				VF																					
46	320/90 R46																			VF						
46	340/85 R46												S/IF													
46	380/90 R46												S/IF							VF						
46	420/80 R46											S														
46	480/80 R46									VF										VF						
46	480/80 R46											S														
46	520/85 R46											S														
46	620/70 R46					S																				
46	750/75 R46			IF																						
46	900/65 R46			IF																						
50	320/90 R50												S/IF							VF						
50	380/90 R50												S/IF							VF						
50	420/95 R50																			VF						
50	480/80 R50									VF	S									VF						
50	480/95 R50									VF	S															
54	320/90 R54												S/IF							VF						
54	380/90 R54											S								VF						

Information

- IF = Improved Flexion
- VF = Very High Flexion
- S = Standard

CIRCONFÉRENCES DE ROULEMENT

DIMENSION ET GAMME	CAI	Entraxe minimum	Diamètre	Circonférence de roulement	RCI	SRI
		mm	mm	mm		
270/65R16 IMP 134A8/122A8 TL X P27	184332	381	755	2300		360
280/70R16 112D TL OMNIBIB	747196	389	805	2400		390
320/65R16 107D TL MULTIBIB	494658	434	827	2452		390
270/65R18 IMP 136A8/124A8 TL X P27	133069	381	810	2472		390
11LR16 122A8 TL X M27	123207	386	850	2515		
320/65R18 109A8/106B TL MULTIBIB	123898	434	875	2594		410
280/70R20 116D TL OMNIBIB	263806	389	904	2690	32	450
340/65R18 113A8/110B TL MULTIBIB	123888	462	911	2719	32	425
340/65R18 149A8/137A8 TL X P27	415969	462	891	2720	32	425
9.5R24 112A8/109B TL AGRIBIB	200987	340	1045	3117	35	500
420/65R20 125A8/125B TL MULTIBIB	122702	552	1064	3135	35	500
560/45R22.5 152D TL CARGOXBIB HEAVY DUTY	743789	702	1080	3191		525
405/70R20 136G TL X M47	123708	539	1076	3194		
440/65R20 128D TL MULTIBIB	675464	580	1090	3260		525
11.2R24 119A8/116B TL AGRIBIB	317247	392	1095	3269	36	525
320/70R24 116D TL OMNIBIB	415039	434	1101	3274		525
445/70R19.5 173A8/180A2 TL XF	489102	585	1110	3331		
425/75R20 148G TL X M47	123706	556	1147	3398		
420/65R24 126D TL MULTIBIB	171560	552	1156	3416		550
360/70R24 122D TL OMNIBIB	198698	479	1153	3418	37	550
12.4R24 119A8/116B TL AGRIBIB	123788	429	1149	3420	37	550
420/65R24 126A8/126B TL MULTIBIB	122712	552	1160	3425		550
500/60R22.5 155D TL CARGOXBIB HEAVY DUTY	441880	654	1172	3454		550
600/50R22.5 159D TL CARGOXBIB	048429	760	1181	3478		550
440/65R24 128D TL MULTIBIB	426389	580	1187	3519		575
380/70R24 125D TL OMNIBIB	085816	507	1188	3520	38	575
710/45R22.5 165D TL CARGOXBIB HIGH FLOTATION	723051	910	1208	3545		575
280/85R28 123A8/120D TL AGRIBIB 2	392931	389	1192	3563		575
445/70R22.5 175A8/182A2 TL XF	073522	585	1192	3582		
13.6R24 124A8/121B TL AGRIBIB	262831	465	1200	3583	38	575
VF 560/60R22.5 IMP 166D TL TRAILXBIB	103824	728	1242	3612		600
525/65R20.5 173F TL XS	109421	687	1200	3640		575
560/60R22.5 161D TL CARGOXBIB HEAVY DUTY	102433	728	1242	3650		600
480/65R24 133D TL MULTIBIB	531721	626	1240	3667	38	600
420/65R28 135D TL MULTIBIB	778211	552	1238	3680		600
445/70R24 151G TL X M47	123642	585	1239	3689		
420/70R24 130D TL OMNIBIB	829095	552	1251	3702	39	600

CIRCONFÉRENCES DE ROULEMENT

DIMENSION ET GAMME	CAI	Entraxe minimum	Diamètre	Circonférence de roulement	RCI	SRI
		mm	mm	mm		
14.9R24 130A8/127B TL AGRIBIB	601563	504	1265	3769		600
12.4R28 126A8/123B TL AGRIBIB	738964	429	1265	3778		600
VF 480/60R28 134D TL XEOBIB	312875	639	1298	3831	39	625
440/65R28 131D TL MULTIBIB	386212	580	1291	3833	39	625
380/70R28 127D TL OMNIBIB	118587	507	1294	3842	39	625
540/65R24 140D TL MULTIBIB	097057	711	1312	3873		625
495/70R24 155G TL X M47	123620	650	1311	3883		
13.6R28 123A8/120B TL AGRIBIB	123782	465	1308	3893	39	625
480/70R24 138D TL OMNIBIB	375821	626	1327	3916		625
VF 600/55R26.5 IMP 170D TL CARGOXBIB HIGH FLOTATION	377726	760	1341	3923		625
16.9R24 134A8/131B TL AGRIBIB	123854	566	1330	3935		625
VF 520/60R28 138D TL XEOBIB	510495	670	1338	3942	40	650
600/55R26.5 165D TL CARGOXBIB HIGH FLOTATION	550621	760	1341	3954		625
480/65R28 136D TL MULTIBIB	897574	626	1339	3970		650
420/70R28 133D TL OMNIBIB	532215	552	1354	4012	40	650
VF 710/50R26.5 IMP 176D TL CARGOXBIB HIGH FLOTATION	343405	910	1380	4022		650
710/50R26.5 170D TL CARGOXBIB HIGH FLOTATION	892516	910	1380	4061		650
14.9R28 134A8/131B TL AGRIBIB	112235	504	1365	4072	40	650
VF 650/55R26.5 IMP 174D TL TRAILXBIB	054878	825	1402	4082		725
VF 650/55R26.5 IMP 174D TL CARGOXBIB HIGH FLOTATION	776393	825	1402	4084		725
800/45R26.5 174D TL CARGOXBIB	248959	1008	1395	4097		675
24R20.5 176F TL XS	109174	778	1374	4148		650
VF 750/50R26 CFO 174D/170E TL FLOATXBIB	982905		1405	4155		675
650/55R26.5 169D TL CARGOXBIB HIGH FLOTATION	693431	825	1402	4158		725
750/50R26 160A8/154D TL MEGAXBIB	478428	956	1404	4162	41	675
750/50R26 160A8/154D TL MEGAXBIB 2	236906	956	1406	4171		675
380/85R30 135A8/135B TL AGRIBIB	836509	507	1416	4194	41	675
VF 600/60R28 146D TL XEOBIB	665184	767	1429	4198	41	675
480/70R28 140D TL OMNIBIB	570026	626	1427	4217	41	675
380/85R30 140A8/140B TL AGRIBIB 2	151572	507	1416	4219	41	675
540/65R28 142D TL MULTIBIB	792274	711	1427	4223	41	675
320/85R34 133A8/130B TL AGRIBIB	122760	434	1420	4239	41	675
320/85R34 133A8/133B TL AGRIBIB 2	908266	434	1421	4243	41	675
16.9R28 141A8/138B TL AGRIBIB	984997	566	1435	4278		675
VF 540/65R30 158D/155E TL AXIOBIB 2	296638	710	1460	4316		700
VF 600/60R30 162D/159E TL AXIOBIB 2	371968	767	1468	4336		700
540/65R30 143D TL MULTIBIB	223153	711	1472	4353		700
12.4R36 124A8 TL AGRIBIB	123952	429	1460	4363	41	700

CIRCONFÉRENCES DE ROULEMENT

DIMENSION ET GAMME	CAI	Entraxe minimum	Diamètre	Circonférence de roulement	RCI	SRI
		mm	mm	mm		
VF 600/60R30 147D TL XEOBIB	065253	767	1493	4379	42	700
540/65R30 150D/146E TL ROADBIB	274757	711	1464	4382		700
480/70R30 141D TL OMNIBIB	599351	626	1482	4388	42	700
16.9R30 137A8/134B TL AGRIBIB	123870	566	1480	4395	42	700
VF 520/80R26 CFO 168A8 TL CEREXBIB	972024	670	1491	4397		700
VF 520/80R26 CFO+ 168A8 TL CEREXBIB 2	850494	670	1491	4400		700
710/50R30.5 173D TL CARGOXBIB	002786	910	1495	4408		700
800/45R30.5 176D TL CARGOXBIB	932951	1008	1495	4408		725
600/65R28 154A8/154B TL MACHXBIB	135288	760	1485	4415	42	700
600/60R30.5 169D TL CARGOXBIB	236518	767	1496	4417		700
VF 620/70R26 CFO 173A8 TL CEREXBIB	656967	790	1513	4458	42	725
380/85R34 137A8/137B TL AGRIBIB	122781	507	1503	4461	42	725
VF 620/70R26 CFO+ 173A8 TL CEREXBIB 2	228272	790	1513	4461	42	725
600/65R28 154D/150E TL MACHXBIB	429970	760	1494	4465	42	700
VF 380/85R34 149A8/149B TL YIELDBIB	305457	510	1510	4471	43	725
12.4R38 131A8/128B TL AGRIBIB	258138	429	1500	4484	42	725
710/55R30 153D TL MACHXBIB	992342	910	1518	4489		725
420/90R30 147A8/147B TL AGRIBIB 2	508522	552	1518	4513	42	725
320/85R38 143A8/143B TL AGRIBIB RC	758001	434	1508	4514	42	725
380/85R34 142A8/142B TL AGRIBIB 2	009860	507	1516.4	4519	42	725
420/90R30 147A8/147B TL AGRIBIB	953332	552	1533	4556	42	725
18.4R30 142A8/139B TL AGRIBIB	123844	611	1550	4602		725
VF 600/70R30 165D TL EVOBIB	266793	774	1574	4616		750
600/70R30 158D/155E TL ROADBIB	217911	774	1569	4630		750
600/70R28 157D/154E TL MACHXBIB	211033	760	1571	4652		725
540/65R34 145D TL MULTIBIB	712064	711	1574	4655	43	750
VF 600/70R30 168D/165E TL AXIOBIB 2	426719	774	1579	4659	43	750
VF 420/85R34 154A8/154B TL YIELDBIB	012445	554	1582	4682	43	750
IF 600/70R30 159D TL AXIOBIB	280086	774	1585	4683	43	750
28LR26 175D TL CARGOXBIB HIGH FLOTATION	224829	907	1581	4685		
600/70R28 157A8/157B TL MACHXBIB	395016	760	1586	4694		725
VF 600/60R34 149D TL XEOBIB	664777	767	1595	4699	43	750
13.6R38 128A8/125B TL AGRIBIB	123992	465	1565	4705	43	750
VF 380/80R38 167D TL SPRAYBIB	352109	510	1577	4712		750
540/65R34 152D TL MULTIBIB	214036	711	1590	4716	43	750
480/70R34 143D TL OMNIBIB	280033	626	1593	4728	43	750
420/85R34 147A8/147B TL AGRIBIB 2	183733	552	1589	4730	43	750
600/70R30 152D TL MACHXBIB	334318	774	1605	4745	43	750

CIRCONFÉRENCES DE ROULEMENT

DIMENSION ET GAMME	CAI	Entraxe minimum	Diamètre	Circonférence de roulement	RCI	SRI
		mm	mm	mm		
620/75R26 166A8/166B TL MEGAXBIB	614320	801	1602	4748	43	750
420/85R34 147A8/147B TL AGRIBIB	788910	552	1595	4751	43	750
380/80R38 142A8/139D TL AGRIBIB 2	187095	507	1595	4755	43	750
VF 620/70R30 CFO 172A8 TL CEREXBIB	886789	790	1615	4760		775
600/70R30 158D TL MACHXBIB	566557	774	1604	4760	43	750
VF 620/70R30 CFO+ 175A8 TL CEREXBIB 2	049288	790	1615	4765		775
650/65R30.5 176D TL CARGOXBIB HIGH FLOTATION	139310	825	1622	4776		775
850/50R30.5 182D TL CARGOXBIB	938016	1073	1628	4778		775
VF 750/65R26 CFO 177A8 TL CEREXBIB	811382	956	1623	4780		750
VF 750/65R26 CFO+ 180A8 TL CEREXBIB 2	132266	956	1623	4786		750
VF 520/85R30 CFO 172A8 TL CEREXBIB	795916	682	1624	4794	46	775
VF 520/85R30 CFO+ 172A8 TL CEREXBIB 2	188276	682	1624	4797		775
750/65R26 171A8/171B TL MEGAXBIB	983217	956	1621	4818		750
VF 1000/50R25 CFO 190D/186E TL FLOATXBIB	713716	1258	1636	4845		775
VF 380/80R38 149A8/149B TL YIELDBIB	870363	510	1592	4851	43	750
VF 750/60R30.5 IMP 187D TL CARGOXBIB HIGH FLOTATION	139588	956	1674	4875		800
520/70R34 148D TL OMNIBIB	939411	676	1651	4887	44	775
VF 320/90R42 163D TL SPRAYBIB	920383	438	1634.5	4890		800
VF 650/60R34 168D/165E TL AXIOBIB 2	202185	831	1653	4895		775
600/65R34 151D TL MULTIBIB	557189	760	1654	4897	44	775
1000/50R25 172A8/166D TL MEGAXBIB 2	852423	1233	1654	4907		750
320/90R42 147A8/147B TL AGRIBIB RC	425361	434	1638	4908	44	800
VF 620/75R30 172D/169E TL AXIOBIB 2	702894	814	1670	4919	44	800
IF 620/75R30 164D TL AXIOBIB	668406	790	1670	4927	44	800
IF 650/60R34 165D TL AXIOBIB	100511	831	1661	4933		775
650/60R34 159D/155E TL ROADBIB	556249	825	1651	4935		775
750/60R30.5 181D TL CARGOXBIB HIGH FLOTATION	101332	956	1675	4936		800
18.4R34 149A8/146B TL AGRIBIB	679786	611	1662	4940	44	775
650/60R34 159D/155E TL MACHXBIB	549996	825	1664	4950		775
VF 710/65R30 CFO+ 179A8 TL CEREXBIB 2	608814	876	1676	4952	44	800
VF 500/85R34 CFO+ 172A8 TL CEREXBIB 2	038009	642	1676	4961		825
540/65R38 147D TL MULTIBIB	114518	711	1675	4965	44	800
420/85R38 144A8/144B TL AGRIBIB	607820	552	1676	4975	44	800
VF 600/60R38 151D TL XEOBIB	349257	767	1698	5023	44	800
IF 710/60R34 164D TL AXIOBIB	712503	900	1696	5030		825
480/70R38 145D TL OMNIBIB	936570	626	1694	5030	44	800
380/95R38 147A8/147B TL AGRIBIB	836033	507	1689	5034		800
420/85R38 149A8/149B TL AGRIBIB 2	048439	552	1690	5035	44	800

CIRCONFÉRENCES DE ROULEMENT

DIMENSION ET GAMME	CAI	Entraxe minimum	Diamètre	Circonférence de roulement	RCI	SRI
		mm	mm	mm		
VF 380/95R38 154A8/154B TL YIELDBIB	873023	510	1703	5044	44	800
VF 650/65R34 170D/167E TL AXIOBIB 2	101906	831	1710	5061		825
IF 650/75R30 166D TL AXIOBIB	828322	838	1721	5071	45	825
620/75R30 168A8/168B TL MEGAXBIB	753673	801	1710	5083	44	800
VF 710/60R34 173D/169E TL AXIOBIB 2	757609	900	1727	5093		825
650/65R34 161D/157E TL ROADBIB	330378	825	1707	5098		825
IF 650/65R34 161D TL AXIOBIB	711975	831	1721	5099		825
VF 650/60R38 155D TL XEOBIB	454365	831	1735	5108	45	825
650/65R34 161D/157E TL MACHXBIB	817386	825	1726	5133		825
VF 650/60R38 170D/167E TL AXIOBIB 2	908973	831	1742	5145	45	825
340/85R46 150A8/150B TL AGRIBIB RC	846786	462	1747	5227	45	825
520/70R38 150D TL OMNIBIB	833744	670	1766	5229	45	825
600/65R38 153D TL MULTIBIB	228045	760	1768	5229	45	825
18.4R38 151A8/148B TL AGRIBIB	100097	611	1770	5267	45	825
800/60R32 IMP 185D TL CARGOXBIB HIGH FLOTATION	322432	1032	1800	5300		875
VF 320/90R46 165D TL SPRAYBIB	684579	438	1736	5350		825
VF 710/60R38 160D TL XEOBIB	324138	900	1814	5356	46	875
650/65R38 157D TL MULTIBIB	292904	825	1819	5380	46	875
650/75R32 167A8/167B TL AGRIBIB 2	533727	875	1827	5395	45	875
620/75R34 170A8/170B TL MEGAXBIB	325025	801	1814	5398		825
650/75R32 172A8/172B TL MEGAXBIB 2	642277	875	1817	5400		875
650/75R32 172A8/172B TL MEGAXBIB	468227	875	1825	5423	45	875
580/70R38 155D TL OMNIBIB	001240	743	1836	5440	46	875
VF 650/60R42 157D TL XEOBIB	220583	831	1840	5441		875
IF 650/65R38 169D TL AXIOBIB	508421	831	1826	5446		875
800/65R32 178A8/178B TL MEGAXBIB	521809	1008	1840	5459	46	875
480/80R42 156A8/156B TL AGRIBIB 2	539386	626	1840	5470	46	875
800/65R32 178A8/178B TL MEGAXBIB 2	135425	1008	1839	5471		875
VF 480/80R42 176D TL SPRAYBIB	929553	626	1838	5471	46	875
IF 710/60R38 172D TL AXIOBIB	220975	900	1844	5486		875
520/85R38 160A8/160B TL AGRIBIB 2	882358	670	1849	5493	46	875
IF 800/65R32 CFO 178A8/178B TL CEREXBIB	651074	1006	1855	5493	46	875
IF 800/65R32 CFO+ 181A8 TL CEREXBIB 2	987406	1006	1855	5501		875
20.8R38 159A8/156B TL AGRIBIB	813266	684	1850	5506	46	875
1050/50R32 184A8/184B TL MEGAXBIB	829536	1310	1856	5510	46	875
680/75R32 164A8/161B TL MACHXBIB	123582	862	1865	5512	46	875
VF 1000/55R32 CFO 197D/193E TL FLOATXBIB	946690	1258	1877	5520		925
420/80R46 151A8/151B TL AGRIBIB 2	885138	552	1854	5524	46	925

CIRCONFÉRENCES DE ROULEMENT

DIMENSION ET GAMME	CAI	Entraxe minimum	Diamètre	Circonférence de roulement	RCI	SRI
		mm	mm	mm		
520/85R38 155A8/155B TL AGRIBIB	303668	670	1855	5529	46	875
VF 380/90R46 173D TL SPRAYBIB	198604	510	1842	5530	46	925
VF 320/90R50 166D TL SPRAYBIB	946508	438	1844	5531		925
1050/50R32 178A8/172D TL MEGAXBIB 2	424273	1310	1866	5537		875
480/80R42 156A8/156B TL AGRIBIB	404096	626	1858	5538	46	875
320/90R50 150A8/150B TL AGRIBIB RC	130813	434	1847	5539	46	925
IF 1000/55R32 CFO 191D/188E TL FLOATXBIB	564739	1258	1877	5540		925
620/70R38 170A8/170B TL MEGAXBIB 2	126128	801	1857	5548		875
420/80R46 151A8/148B TL AGRIBIB	122770	552	1872	5555	46	925
620/70R38 170A8/170B TL MEGAXBIB	476088	801	1864	5557	46	875
VF 710/60R42 176D/173E TL AXIOBIB 2	941770	900	1885.3	5574		925
380/90R46 157A8/157B TL AGRIBIB RC	799905	507	1864	5583	46	925
VF 900/60R32 CFO+ 191A8 TL CEREXBIB 2	430737	1120	1903	5618		925
900/60R32 181A8/181B TL MEGAXBIB	824122	1114	1894	5626	46	925
900/60R32 181A8/181B TL MEGAXBIB 2	166896	1114	1899	5635		925
710/75R34 178A8/178B TL MEGAXBIB	543107	910	1900	5637	47	925
IF 900/60R32 CFO 185A8 TL CEREXBIB	752825	1120	1906	5643		925
1050/50R32 178A8 TL MEGAXBIB	236234	1310	1902	5649	46	875
710/75R34 178A8/178B TL MEGAXBIB 2	312036	910	1909	5671	47	925
VF 710/60R42 161D TL XEOBIB	144294	900	1920	5675	47	925
VF 650/65R42 174D/171E TL AXIOBIB 2	387916	831	1920	5680	47	925
650/65R42 165D/161E TL ROADBIB	075643	825	1932	5693		925
IF 680/85R32 CFO 179A8/179B TL CEREXBIB	932041	869	1935	5711	47	925
650/65R42 158D TL MULTIBIB	167733	825	1931	5722	47	925
800/70R32 181A8/181B TL MEGAXBIB	695992	1008	1936	5725		925
VF 480/80R46 164A8/164B TL YIELDBIB	842300	626	1933	5732	47	925
800/70R32 181A8/181B TL MEGAXBIB 2	366785	1008	1927	5737		925
IF 1000/55R32 CFO 188A8 TL CEREXBIB	131720	1258	1931	5758		925
650/75R38 169A8/169B TL MACHXBIB	219467	825	1948	5761	47	925
520/85R42 157A8/157B TL AGRIBIB	122791	670	1945	5771	47	925
620/70R42 160D TL OMNIBIB	989457	801	1953	5781	47	925
520/85R42 162A8/162B TL MEGAXBIB	645194	670	1937	5783	47	925
IF 800/70R32 CFO 182A8/182B TL CEREXBIB	525718	1004	1958	5788		925
VF 480/80R46 177D TL SPRAYBIB	159186	626	1943	5790	47	925
IF 800/70R32 CFO+ 185A8 TL CEREXBIB 2	789156	1004	1950	5800		925
710/70R38 171D TL MACHXBIB	708197	910	1973	5804	47	925
480/80R46 158A8/158B TL AGRIBIB 2	622709	626	1945	5804	47	925
VF 520/85R42 CFO 177A8 TL CEREXBIB	934265	682	1953	5807	47	925

CIRCONFÉRENCES DE ROULEMENT

DIMENSION ET GAMME	CAI	Entraxe minimum	Diamètre	Circonférence de roulement	RCI	SRI
		mm	mm	mm		
VF 520/85R42 CFO+ 177A8 TL CEREXBIB 2	270459	682	1953	5807		925
520/85R42 162A8/162B TL AGRIBIB 2	405859	670	1958	5810	47	925
380/90R50 151A8/151B TL AGRIBIB RC	036849	507	1935	5813	47	975
IF 680/75R38 180A8 TL CEREXBIB	833220	830	1965	5823		975
900/50R42 168D TL MACHXBIB	832458	1114	1970	5826	47	975
VF 380/90R50 175D TL SPRAYBIB	722276	510	1951	5836	47	975
IF 380/90R50 167A8/167B TL AGRIBIB RC	212359	510	1953	5841	47	975
VF 320/90R54 168D TL SPRAYBIB	044008	438	1950	5843	47	975
320/90R54 151A8/151B TL AGRIBIB RC	272304	434	1950	5852	47	975
620/70R42 166A8/166B TL MEGAXBIB	100268	801	1961	5857	47	925
480/80R46 158A8/158B TL AGRIBIB	637231	626	1948	5874	47	925
VF 900/60R38 CFO+ 193A8 TL CEREXBIB 2	439024	1144	2029	5993		975
VF 710/70R42 179D TL EVOBIB	363574	910	2042	6003		975
IF 900/60R38 CFO 188A8 TL CEREXBIB	853436	1144	2029	6017	48	975
IF 900/60R38 CFO 184A8 TL CEREXBIB	296920	1144	2033	6017	48	975
710/70R42 173D/170E TL ROADBIB	885975	910	2028	6025		975
IF 680/80R38 CFO+ 182A8 TL CEREXBIB 2	953912	870	2020	6030		975
VF 480/80R50 166A8/166B TL YIELDBIB	309830	626	2039	6034	48	975
VF 580/85R42 CFO+ 183A8 TL CEREXBIB 2	844076	754	2040	6040		975
VF 900/60R38 CFO 196D/192E TL FLOATXBIB	098689	1144	2033	6041		975
620/70R46 162D TL MACHXBIB	131721	801	2042	6055		975
IF 800/70R38 CFO 184A8/184B TL CEREXBIB	646846	1004	2048	6072	48	975
IF 650/85R38 179D TL AXIOBIB	084900	821	2050	6078	48	975
IF 800/70R38 CFO 187A8 TL CEREXBIB	445898	1004	2051	6079	48	975
IF 800/70R38 CFO+ 187A8 TL CEREXBIB 2	610997	1004	2051	6079	48	975
520/85R46 158A8/155B TL AGRIBIB	122780	670	2050	6088	48	975
VF 650/85R38 182D/179E TL AXIOBIB 2	655949	845	2063	6088		975
IF 800/70R38 179D TL AXIOBIB	528166	1004	2067	6089	48	975
650/85R38 173A8/173B TL MACHXBIB	118628	825	2063	6092	48	975
800/70R38 173D TL MACHXBIB	887730	1008	2066	6093	48	975
VF 800/70R38 187D/184E TL AXIOBIB 2	136377	1004	2072	6096		975
650/85R38 173A8/173B TL MEGAXBIB	173491	825	2048	6100	48	975
VF 480/80R50 179D TL SPRAYBIB	431251	626	2045	6101	48	975
VF 710/70R42 182D/179E TL AXIOBIB 2	523668	910	2066	6104	48	975
520/85R46 164A8/164B TL AGRIBIB 2	120922	670	2059	6110	48	975
IF 710/70R42 179D TL AXIOBIB	771752	910	2062	6115	48	975
480/80R50 159A8/159B TL AGRIBIB 2	263049	626	2050	6116	48	975
VF 420/95R50 177D TL SPRAYBIB	085405	554	2052	6118	48	1025

CIRCONFÉRENCES DE ROULEMENT

DIMENSION ET GAMME	CAI	Entraxe minimum	Diamètre	Circonférence de roulement	RCI	SRI
		mm	mm	mm		
620/70R46 162A8/162B TL MACHXBIB	122723	801	2061	6122	48	975
380/90R54 152A8/152B TL AGRIBIB 2	075615	507	2054	6129	48	1025
VF 380/90R54 176D TL SPRAYBIB	816598	510	2049	6131	48	1025
480/80R50 159A8/159B TL AGRIBIB	471947	626	2056	6135	48	975
710/70R42 173D TL MACHXBIB	790388	910	2088	6195	48	975
VF 710/70R42 CFO+ 188A8 TL CEREXBIB 2	499992	910	2097	6207		975
IF 710/70R42 CFO 182A8 TL CEREXBIB	003912	910	2097	6230		975
VF 900/60R42 CFO+ 195A8 TL CEREXBIB 2	856296	1108	2118	6281		1025
IF 900/60R42 186D TL AXIOBIB	111950	1144	2123	6304	49	1025
VF 900/60R42 189D/185E TL AXIOBIB 2	428922	1108	2158	6357	49	1025
IF 710/85R38 178D TL AXIOBIB	992951	918	2159	6365	49	1025
710/75R42 175D/171E TL ROADBIB	378080	910	2143	6368		1025
VF 710/75R42 184D/180E TL AXIOBIB 2	259635	910	2153	6370	49	1025
IF 800/70R42 CFO+ 189A8 TL CEREXBIB 2	818789	1004	2151	6387	49	1025
VF 650/85R42 183D/180E TL AXIOBIB 2	530764	845	2164	6393	49	1025
IF 710/75R42 176D TL AXIOBIB	037489	910	2161	6395	49	1025
710/75R42 175D/171E TL MACHXBIB	015540	910	2158	6408		1025
VF 750/70R44 186D/183E TL AXIOBIB 2	681569	941	2180	6438		1025
VF 480/95R50 170A8/170B TL YIELDBIB	252129	626	2186	6464	49	1075
480/95R50 164A8/164B TL AGRIBIB	491183	626	2175	6484		1075
IF 750/75R46 186D TL AXIOBIB	487001	941	2287	6819	50	1125
IF 900/65R46 190D TL AXIOBIB	162365	1108	2322	6888		1125

INDICES DE CHARGE

INDICE DE CHARGE	KG	LBS	INDICE DE CHARGE	KG	LBS	INDICE DE CHARGE	KG	LBS	INDICE DE CHARGE	KG	LBS
100	800	1 760	151	3 450	7 600	202	15 000	33 100	253	65 000	143 500
101	825	1 820	152	3 550	7 850	203	15 500	34 200	254	67 000	147 500
102	850	1 870	153	3 650	8 050	204	16 000	35 300	255	69 000	152 000
103	875	1 930	154	3 750	8 250	205	16 500	36 400	256	71 000	156 500
104	900	1 980	155	3 875	8 550	206	17 000	37 500	257	73 000	161 000
105	925	2 040	156	4 000	8 800	207	17 500	38 600	258	75 000	165 500
106	950	2 090	157	4 125	9 100	208	18 000	39 700	259	77 500	171 000
107	975	2 150	158	4 250	9 350	209	18 500	40 800	260	80 000	176 500
108	1 000	2 200	159	4 375	9 650	210	19 000	41 900	261	82 500	182 000
109	1 030	2 270	160	4 500	9 900	211	19 500	43 000	262	85 000	187 500
110	1 060	2 340	161	4 625	10 200	212	20 000	44 100	263	87 500	193 000
111	1 090	2 400	162	4 750	10 500	213	20 600	45 400	264	90 000	198 500
112	1 120	2 470	163	4 875	10 700	214	21 200	46 700	265	92 500	204 000
113	1 150	2 540	164	5 000	11 000	215	21 800	48 100	266	95 000	209 500
114	1 180	2 600	165	5 150	11 400	216	22 400	49 400	267	97 500	215 000
115	1 215	2 680	166	5 300	11 700	217	23 000	50 700	268	100 000	220 500
116	1 250	2 760	167	5 450	12 000	218	23 600	52 000	269	103 000	227 000
117	1 285	2 830	168	5 600	12 300	219	24 300	53 600	270	106 000	233 500
118	1 320	2 910	169	5 800	12 800	220	25 000	55 100	271	109 000	240 500
119	1 360	3 000	170	6 000	13 200	221	25 750	56 800	272	112 000	247 000
120	1 400	3 080	171	6 150	13 600	222	26 500	58 400	273	115 000	253 500
121	1 450	3 200	172	6 300	13 900	223	27 250	60 000	274	118 000	260 000
122	1 500	3 300	173	6 500	14 300	224	28 000	61 500	275	121 500	267 000
123	1 550	3 420	174	6 700	14 800	225	29 000	64 000	276	125 000	275 500
124	1 600	3 520	175	6 900	15 200	226	30 000	66 000	277	128 500	283 500
125	1 650	3 640	176	7 100	15 700	227	30 750	68 000	278	132 000	291 000
126	1 700	3 740	177	7 300	16 100	228	31 500	69 500	279	136 000	300 000
127	1 750	3 860	178	7 500	16 500	229	32 500	71 500	280	140 000	308 500
128	1 800	3 960	179	7 750	17 100	230	33 500	74 000	281	145 000	319 500
129	1 850	4 080	180	8 000	17 600	231	34 500	76 000	282	150 000	330 500
130	1 900	4 180	181	8 250	18 200	232	35 500	78 500	283	155 000	341 500
131	1 950	4 300	182	8 500	18 700	233	36 500	80 500	284	160 000	352 500
132	2 000	4 400	183	8 750	19 300	234	37 500	82 500	285	165 000	364 000
133	2 060	4 540	184	9 000	19 800	235	38 750	85 500	286	170 000	375 000
134	2 120	4 680	185	9 250	20 400	236	40 000	88 000	287	175 000	386 000
135	2 180	4 800	186	9 500	20 900	237	41 250	91 000	288	180 000	397 000
136	2 240	4 940	187	9 750	21 500	238	42 500	93 500	289	185 000	408 000
137	2 300	5 080	188	10 000	22 000	239	43 750	96 500	290	190 000	419 000
138	2 360	5 200	189	10 300	22 700	240	45 000	99 000	291	195 000	430 000
139	2 430	5 360	190	10 600	23 400	241	46 250	102 000	292	200 000	441 000
140	2 500	5 520	191	10 900	24 000	242	47 500	104 500	293	206 000	454 000
141	2 575	5 680	192	11 200	24 700	243	48 750	107 500	294	212 000	467 500
142	2 650	5 840	193	11 500	25 400	244	50 000	110 000	295	218 000	480 500
143	2 725	6 000	194	11 800	26 000	245	51 500	113 500	296	224 000	494 000
144	2 800	6 150	195	12 150	26 800	246	53 000	117 000	297	230 000	507 000
145	2 900	6 400	196	12 500	27 600	247	54 500	120 000	298	236 000	520 500
146	3 000	6 600	197	12 850	28 300	248	56 000	123 500	299	243 000	535 500
147	3 075	6 800	198	13 200	29 100	249	58 000	128 000	300	250 000	551 000
148	3 150	6 950	199	13 600	30 000	250	60 000	132 500	301	257 500	567 500
149	3 250	7 150	200	14 000	30 900	251	61 500	135 500	302	265 000	584 000
150	3 350	7 400	201	14 500	32 000	252	63 000	139 000	303	272 500	600 500

NOUVEAUX TABLEAUX CHARGES/PRESSIONS

NOUVEAUX TABLEAUX CHARGES/PRESSIONS À 10 ET 30 KM/H POUR LES PNEUS TRACTEURS MICHELIN ULTRAFLEX TECHNOLOGIE (MUT)

MICHELIN est depuis toujours un promoteur actif de l'évolution des normes visant à faire bénéficier ses clients des dernières révolutions technologiques !

L'avancée du télégonflage sur le marché agricole a exigé une évolution des normes IF (Improved Flexion) et VF (Very high Flexion), c'est chose faite depuis Février 2019.



Les nouvelles lignes charges/pressions à 10 et 30 km/h pour les pneus tracteurs MUT permettent d'adapter la pression des pneus à l'usage et au contexte d'utilisation. Associés à un système de télégonflage optimisant ces variations en temps réel, les pneus MICHELIN ULTRAFLEX peuvent alors offrir le meilleur de leurs performances !

- A basse pression au champ, les sols sont protégés, la productivité est confirmée.
- A pression plus élevée sur route, la vitesse est privilégiée, tout en maîtrisant la consommation de carburant et en assurant une sécurité et un confort de conduite



DES PREUVES EN CHIFFRES

(Exemple de calcul basé sur MACHXBIB (standard), AXIOBIB (IF) et AXIOBIB 2 (VF) – Dimension 710/70 R42)

GAIN DE PRESSION ACCESSIBLE AVEC UNE CHARGE DE 5500 KG

(bar)	10 km/h	30 km/h	65 km/h
Standard	1	1.3	1.6
IF	 1	 1.1	 1.2
VF	0.8	0.9	1

GAIN DE CHARGE ACCESSIBLE AVEC UNE PRESSION DE 1,2 BAR

(kg)	10 km/h	30 km/h	65 km/h
Standard	6200	5200	4500
IF	 6200	 5700	 5500
VF	7000	6400	6300

ZEN@TERRA®

AU-DELÀ DU PNEU POUR PROTÉGER VOS SOLS



PROTECTION

- **+4%* DE RENDEMENT**

* 4% de rendement agronomique prouvé par l'étude Harper Adams University depuis 2014 pour la technologie Ultraflex.



PRODUCTIVITÉ

- **+30%** DE TRACTION**

** Étude menée en interne sur les pneus MICHELIN EVOBIB vs MICHELIN AXIOBIB.



RENTABILITÉ

- **RÉDUCTION DE LA CONSOMMATION DE CARBURANT**
- **SÉCURITÉ ET MAÎTRISE SUR ROUTE AMÉLIORÉES**



PILOTAGE DE LA PRESSION EN DIRECT DEPUIS LA CABINNE



APP. AGROPRESSURE
PRESSIONS RECOMMANDÉES

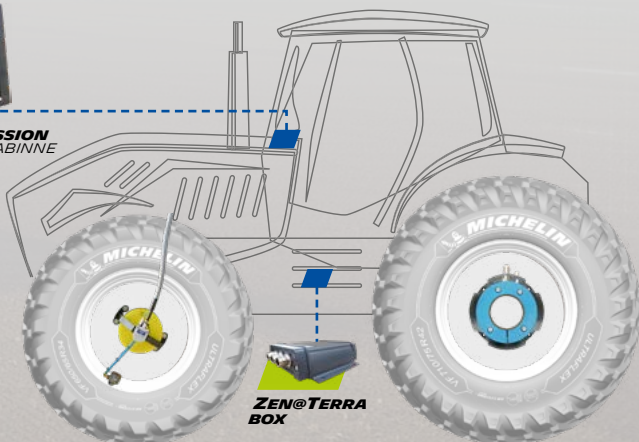

ZEN@TERRA BOX

UN PNEU MICHELIN TECHNOLOGIQUE

- Augmentez encore plus vos bénéfices en utilisant un pneu Michelin ULTRAFLEX



UN PILOTAGE AUTOMATIQUE DES PRESSIONS

- en 2 clics sur le tableau de bord Isobus du tracteur

UN SYSTÈME DE TÉLÉGONFLAGE PTG

- Permettant d'adapter la pression des pneus même en roulant



UN SUPPORT MICHELIN

- Aide au paramétrage (via l'application Agropressure ZEN@TERRA)
- Accompagnement à la prise en main
- Support téléphonique dédié

ZEN@TERRA
Une solution MICHELIN,
en partenariat avec



MICHELIN ULTRAFLEX TECHNOLOGIES



PLUS GRAND RESPECT DES SOLS

Grâce à une plus grande surface d'empreinte, les pneumatiques dotés de la technologie MICHELIN Ultraflex préservent vos sols des phénomènes de compaction et d'ornièrage.

L'air et l'eau circulent ainsi plus librement. En conséquence, les conditions sont optimum pour des rendements agronomiques maximum.

PLUS D'ÉCONOMIE DE CARBURANT

La plus grande surface d'empreinte au sol augmente considérablement la capacité de traction de ces pneumatiques, réduisant ainsi le taux de patinage : vous travaillez plus vite et économisez du carburant.

PLUS D'ENDURANCE ET DE LONGÉVITÉ

Des flancs renforcés et des mélanges de caoutchouc spéciaux rendent la carcasse des pneumatiques dotés de la technologie MICHELIN Ultraflex extrêmement endurante, même à plus basse pression⁽¹⁾. Résultat : un meilleur retour sur investissement.

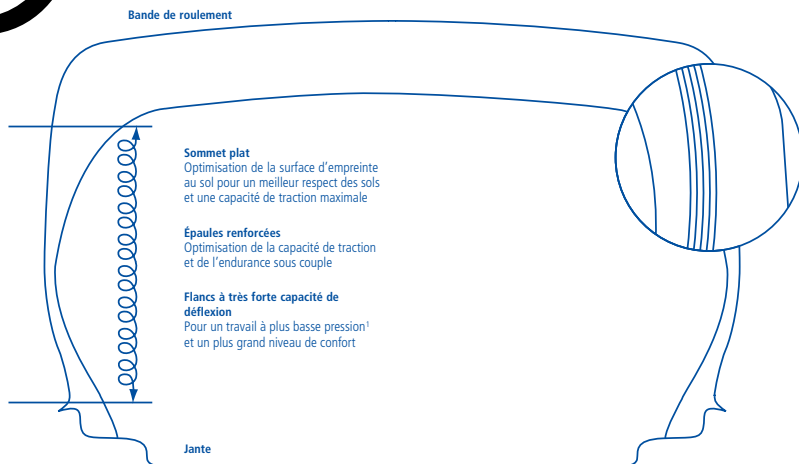
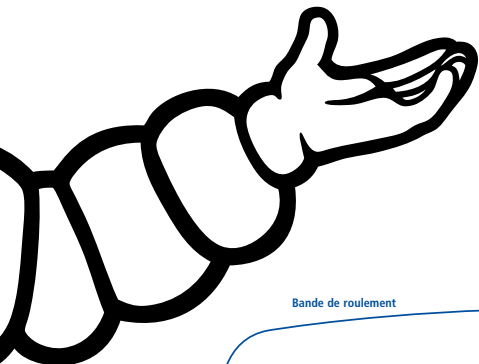

(1) dans le respect de nos recommandations, en comparaison avec des pneumatiques de technologie classique

LISTE DES PNEUS DONT LA FABRICATION A ÉTÉ ARRÊTÉE

Cette documentation technique est conçue à titre informatif uniquement.

Ce n'est pas un document commercial.

Veuillez consulter votre représentant commercial Michelin local pour connaître la disponibilité des pneus.

CAI	GAMME	DIMENSION
836509	AGRIBIB	380/85R30 135A8/135B TL
953332	AGRIBIB	420/90R30 147A8/147B TL
122760	AGRIBIB	320/85R34 133A8/130B TL
122781	AGRIBIB	380/85R34 137A8/137B TL
788910	AGRIBIB	420/85R34 147A8/147B TL
607820	AGRIBIB	420/85R38 144A8/144B TL
303668	AGRIBIB	520/85R38 155A8/155B TL
404096	AGRIBIB	480/80R42 156A8/156B TL
122791	AGRIBIB	520/85R42 157A8/157B TL
122770	AGRIBIB	420/80R46 151A8/148B TL
637231	AGRIBIB	480/80R46 158A8/158B TL
122780	AGRIBIB	520/85R46 158A8/155B TL
471947	AGRIBIB	480/80R50 159A8/159B TL
550621	CARGOXBIB HIGH FLOTATION	600/55R26.5 165D TL
892516	CARGOXBIB HIGH FLOTATION	710/50R26.5 170D TL
693431	CARGOXBIB HIGH FLOTATION	650/55R26.5 169D TL
101332	CARGOXBIB HIGH FLOTATION	750/60R30.5 181D TL
972024	CEREXBIB	VF 520/80R26 CFO 168A8 TL
656967	CEREXBIB	VF 620/70R26 CFO 173A8 TL
811382	CEREXBIB	VF 750/65R26 CFO 177A8 TL
886789	CEREXBIB	VF 620/70R30 CFO 172A8 TL
795916	CEREXBIB	VF 520/85R30 CFO 172A8 TL
651074	CEREXBIB	IF 800/65R32 CFO 178A8/178B TL
752825	CEREXBIB	IF 900/60R32 CFO 185A8 TL
525718	CEREXBIB	IF 800/70R32 CFO 182A8/182B TL
853436	CEREXBIB	IF 900/60R38 CFO 188A8 TL
296920	CEREXBIB	IF 900/60R38 CFO 184A8 TL
646846	CEREXBIB	IF 800/70R38 CFO 184A8/184B TL
445898	CEREXBIB	IF 800/70R38 CFO 187A8 TL
934265	CEREXBIB	VF 520/85R42 CFO 177A8 TL
003912	CEREXBIB	IF 710/70R42 CFO 182A8 TL
478428	MEGAXBIB	750/50R26 160A8/154D TL
521809	MEGAXBIB	800/65R32 178A8/178B TL
824122	MEGAXBIB	900/60R32 181A8/181B TL
122712	X M108	420/65R24 126A8/126B TL
123582	X M28	680/75R32 164A8/161B TL



MICHELIN EVOBIB

**LA BANDE DE ROULEMENT
2 EN 1 : ADAPTATIVE
DESIGN TECHNOLOGY**



POUR TRACTEURS DE FORTE PUISSANCE > 200 CV

Fonctionnement optimal avec un CTIS

(Système de Télégonflage conseillé)



TECHNOLOGIE DE PNEUS « 2 EN 1 »

Configuration adaptative : route, surfaces agricoles et champs

VF Très basse pression



PRODUCTIVITÉ

- longévité
- économies de carburant
- 30% de motricité supplémentaire⁽¹⁾



PROTECTION DES SOLS

- Surface d'empreinte accrue de 20%⁽¹⁾
- Basse pression sur les surfaces agricoles



STABILITÉ à grande vitesse ⁽²⁾

Barrette centrale continue

(1) Étude interne -France, Ladoux MICHELIN EVOBIB VF 710/70R42 vs AXIOBIB IF 710/70R42 à 0.8b

(2) Dans la limite des lois en vigueur dans le pays

DIMENSIONS

VF 600/70R30 165D TL

VF 710/70R42 179D TL

MICHELIN EVOBIB

Caractéristiques & Pression en bar / psi – Charges par pneu en kg*

Ø pouces	Description	CAI	e mm	D mm	R' mm	Cdr. mm	Jante(s) recommandée(s)	Jante(s) tolérée(s)	Chambre à air (Code)	Volume interne 75% (litres)	Profond. de sculpture (mm)		
30	VF 600/70R30 165D TL	266793	608	1574	668	4616	DW21B (A)	DW20B (A)	737	468	51		
Bar	0.4	0.5	0.6	0.7	0.8	0.9	1	1.1	1.2	1.3	1.4	1.5	1.6
Psi	6	7	9	10	12	13	15	16	17	19	20	22	23
10 km/h			3080	3330	3575	3850	4125	4400	4675	4925	5170	5420	5665
30 km/h			2855	3085	3315	3570	3825	4080	4335	4565	4795	5025	5255
65 km/h			2800	3025	3250	3500	3750	4000	4250	4475	4700	4925	5150
65 km/h Dual	2075	2270	2470	2665	2860	3080	3300	3520	3740	3940	4135	4335	4530

Ø pouces	Description	CAI	e mm	D mm	R' mm	Cdr. mm	Jante(s) recommandée(s)	Jante(s) tolérée(s)	Chambre à air (Code)	Volume interne 75% (litres)	Profond. de sculpture (mm)		
42	VF 710/70R42 179D TL	363574	725	2042	875	6003	DW25B (A)	DW23B (A) MW25B (A)	802	867	54		
Bar	0.4	0.5	0.6	0.7	0.8	0.9	1	1.1	1.2	1.3	1.4	1.5	1.6
Psi	6	7	9	10	12	13	15	16	17	19	20	22	23
10 km/h			4675	5090	5500	5860	6215	6575	6930	7330	7730	8125	8525
30 km/h			4335	4720	5100	5430	5765	6095	6425	6795	7165	7535	7905
65 km/h			4250	4625	5000	5325	5650	5975	6300	6665	7025	7390	7750
65 km/h Dual	3125	3445	3765	4080	4400	4685	4975	5260	5545	5865	6185	6500	6820

***REMARQUES**

La pression de gonflage se détermine toujours en fonction de la charge par pneu, de la vitesse et du travail à réaliser.
 Nos préconisations ci-dessus sont fournies sous réserve de modifications postérieures à la date de diffusion de ces tableaux (mars 2021).
 Les données techniques sont susceptibles d'évoluer sans information préalable.

- Pour usage en dévers >20% : ajouter 0,4 bar.
- 65 km/h Dual : Utilisation en jumelé jusqu' à 65 km/h.
- 65 km/h : Utilisation en simple jusqu' à 65 km/h.
- Pour les pressions champs de 0,4 à 1,5 bar = 1.8 bar sur route.
- Pour la pression champs à 1,6 bar = 2,0 bar sur route.



MICHELIN ROADBIB



DURÉE DE VIE

- Performance extraordinaire en terme de longévité
- Grâce à un design exclusif (Bande de roulement, composition)
- Pneu directionnel



CONFORT IMPRESSIONNANT

- Espace réduit entre les pavés
- Isolation acoustique



ÉCONOMIES

- Faible résistance au roulement, donc consommation de carburant réduite



MANUTENTION ET SÉCURITÉ

- Meilleure maniabilité grâce à plus de caoutchouc au sol et une nouvelle sculpture
- Bonne adhérence des pneus sur route mouillée grâce aux évacuations verticales

DIMENSIONS

600/70R30 158D/155E TL **NEW**

650/60R34 159D/155E TL **NEW**

650/65R34 161D/157E TL **NEW**

650/65R42 165D/161E TL **NEW**

710/70R42 173D/170E TL

710/75R42 175D/171E TL **NEW**

MICHELIN ROADBIB

Caractéristiques & Pression en bar / psi – Charges par pneu en kg*

Ø pouces	Description	CAI	e mm	D mm	R' mm	Cdr. mm	Jante(s) recommandée(s)	Jante(s) tolérée(s)	Chambre à air (Code)	Volume interne 75% (litres)	Profond. de sculpture (mm)		
30	540/65R30 150D/146E TL NEW	274757	547	1464	655	4365	DW16L	W18L	754	332	32.5		
Bar	0.4	0.6	0.8	1	1.2	1.4	1.6	1.8	2	2.2	2.4	2.6	2.8
Psi	6	9	12	15	17	20	23	26	29	32	35	38	41
10 km/h	1930	2185	2445	2700	3000	3300	3600	3900	4200	4405	4615	4820	5025
30 km/h	1480	1755	2030	2310	2585	2860	3135	3315	3495	3675	3855		
40 km/h		1695	1955	2210	2470	2725	2985	3155	3330	3500	3670		
50 km/h		1630	1875	2120	2370	2615	2860	3025	3190	3355	3520		
65 km/h			1800	2030	2265	2495	2725	2880	3040	3195	3350		
70 km/h			1640	1850	2060	2270	2480	2610	2740	2870	3000		

Ø pouces	Description	CAI	e mm	D mm	R' mm	Cdr. mm	Jante(s) recommandée(s)	Jante(s) tolérée(s)	Chambre à air (Code)	Volume interne 75% (litres)	Profond. de sculpture (mm)		
30	600/70R30 158D/155E TL	217911	610	1569	684	4630	DW20B (A)	DW18L DW21B (A)	737	468	40		
Bar	0.4	0.6	0.8	1	1.2	1.4	1.6	1.8	2	2.2	2.4	2.6	2.8
Psi	6	9	12	15	17	20	23	26	29	32	35	38	41
10 km/h	2475	2830	3185	3540	3955	4375	4790	5210	5625	5815	6000	6190	6375
30 km/h	1900	2285	2665	3050	3435	3815	4200	4375	4545	4720	4890		
40 km/h		2190	2550	2910	3275	3635	3995	4160	4325	4490	4655		
50 km/h		2100	2445	2795	3140	3490	3835	3995	4150	4310	4465		
65 km/h			2360	2685	3005	3325	3650	3800	3950	4100	4250		
70 km/h			2150	2445	2735	3030	3320	3460	3600	3735	3875		

Ø pouces	Description	CAI	e mm	D mm	R' mm	Cdr. mm	Jante(s) recommandée(s)	Jante(s) tolérée(s)	Chambre à air (Code)	Volume interne 75% (litres)	Profond. de sculpture (mm)		
34	650/60R34 159D/155E TL NEW	556249	650	1651	749	4915	DW20B (A)	DW21B (A) DW23B (A)	823	500	39.3		
Bar	0.4	0.6	0.8	1	1.2	1.4	1.6	1.8	2	2.2	2.4	2.6	2.8
Psi	6	9	12	15	17	20	23	26	29	32	35	38	41
10 km/h	2475	2800	3125	3450	3885	4320	4755	5190	5625	5860	6095	6330	6565
30 km/h	1900	2285	2665	3050	3435	3815	4200	4410	4615	4825	5030		
40 km/h		2190	2550	2910	3275	3635	3995	4195	4395	4590	4790		
50 km/h		2100	2445	2795	3140	3490	3835	4025	4215	4405	4595		
65 km/h			2300	2640	2975	3310	3650	3830	4015	4195	4375		
70 km/h			2095	2400	2710	3015	3320	3460	3600	3735	3875		

* Se référer aux remarques en fin des tableaux de cette gamme

MICHELIN ROADBIB

Caractéristiques & Pression en bar / psi – Charges par pneu en kg*

Ø pouces	Description	CAI	e mm	D mm	R' mm	Cdr. mm	Jante(s) recommandée(s)	Jante(s) tolérées(s)	Chambre à air (Code)	Volume interne 75% (litres)	Profond. de sculpture (mm)		
34	650/65R34 161D/157E TL NEW	330378	679	1701	769	5060	DW20B (A)	DW21B (A) DW23B (A)	823	555	39.5		
Bar	0.4	0.6	0.8	1	1.2	1.4	1.6	1.8	2	2.2	2.4	2.6	2.8
Psi	6	9	12	15	17	20	23	26	29	32	35	38	41
10 km/h	2700	3090	3475	3865	4290	4720	5145	5575	6000	6235	6470	6705	6940
30 km/h	2070	2470	2865	3265	3660	4055	4455	4670	4890	5105	5320		
40 km/h		2385	2755	3130	3500	3875	4245	4450	4655	4860	5065		
50 km/h		2290	2645	3000	3360	3715	4070	4265	4465	4660	4855		
65 km/h			2575	2900	3225	3550	3875	4065	4250	4440	4625		
70 km/h			2345	2640	2935	3230	3525	3675	3825	3975	4125		

Ø pouces	Description	CAI	e mm	D mm	R' mm	Cdr. mm	Jante(s) recommandée(s)	Jante(s) tolérées(s)	Chambre à air (Code)	Volume interne 75% (litres)	Profond. de sculpture (mm)		
42	650/65R42 165D/161E TL NEW	075643	633	1932	870	5733	DW20B (A)	DW23B (A) DW21B(A)	802	643	43.2		
Bar	0.4	0.6	0.8	1	1.2	1.4	1.6	1.8	2	2.2	2.4	2.6	2.8
Psi	6	9	12	15	17	20	23	26	29	32	35	38	41
10 km/h	3000	3400	3800	4200	4675	5145	5620	6090	6565	6855	7145	7435	7725
30 km/h	2300	2730	3165	3595	4025	4460	4890	5150	5410	5665	5925		
40 km/h		2660	3060	3460	3855	4255	4655	4900	5150	5395	5640		
50 km/h		2550	2935	3315	3700	4080	4465	4700	4940	5175	5410		
65 km/h			2800	3165	3525	3890	4250	4475	4700	4925	5150		
70 km/h			2550	2880	3210	3540	3870	4060	4250	4435	4625		

Ø pouces	Description	CAI	e mm	D mm	R' mm	Cdr. mm	Jante(s) recommandée(s)	Jante(s) tolérées(s)	Chambre à air (Code)	Volume interne 75% (litres)	Profond. de sculpture (mm)		
42	710/70R42 173D/170E TL	885975	710	2028	915	6025	DW23B (A)	DW25B (A)	802	867	37.5		
Bar	0.4	0.6	0.8	1	1.2	1.4	1.6	1.8	2	2.2	2.4	2.6	2.8
Psi	6	9	12	15	17	20	23	26	29	32	35	38	41
10 km/h	3750	4275	4800	5325	6000	6675	7350	8025	8700	8965	9225	9490	9750
30 km/h	2875	3470	4065	4660	5250	5845	6440	6700	6960	7215	7475		
40 km/h		3285	3855	4425	4990	5560	6130	6380	6625	6875	7120		
50 km/h		3150	3695	4240	4790	5335	5880	6115	6355	6590	6825		
65 km/h			3550	4065	4575	5090	5600	5825	6050	6275	6500		
70 km/h			3230	3695	4165	4630	5095	5320	5550	5775	6000		

* Se référer aux remarques en fin des tableaux de cette gamme

MICHELIN ROADBIB

Caractéristiques & Pression en bar / psi – Charges par pneu en kg*

Ø pouces	Description	CAI	e mm	D mm	R' mm	Cdr. mm	Jante(s) recommandée(s)	Jante(s) tolérée(s)	Chambre à air (Code)	Volume interne 75% (litres)	Profond. de sculpture (mm)		
42	710/75R42 175D/171E TL NEW	378080	744	2140	957	6350	DW23B (A)	DW25B (A) DW21B(A)	802	950	42.6		
Bar	0.4	0.6	0.8	1	1.2	1.4	1.6	1.8	2	2.2	2.4	2.6	2.8
Psi	6	9	12	15	17	20	23	26	29	32	35	38	41
10 km/h	3975	4525	5075	5625	6300	6975	7650	8325	9000	9340	9675	10015	10350
30 km/h	3050	3690	4335	4975	5615	6260	6900	7160	7420	7675	7935		
40 km/h		3560	4160	4765	5365	5970	6570	6815	7065	7310	7555		
50 km/h		3415	3990	4570	5145	5725	6300	6535	6775	7010	7245		
65 km/h			3750	4315	4875	5440	6000	6225	6450	6675	6900		
70 km/h			3415	3925	4440	4950	5460	5635	5805	5980	6150		

***REMARQUES**

La pression de gonflage se détermine toujours en fonction de la charge par pneu, de la vitesse et du travail à réaliser.

Nos préconisations ci-dessus sont fournies sous réserve de modifications postérieures à la date de diffusion de ces tableaux (mars 2021).

Les données techniques sont susceptibles d'évoluer sans information préalable.

• Pour un usage labour et d'autres usages champ sous couple élevé, utiliser la ligne 30 km/h.

• Lors d'un usage en monte simple :

- Pour usage en dévers >20% : ajouter 0,4 bar.

- Pour usage routier intensif >50% : ajouter 0,4 bar.

TRACTEURS

FORTE PUISSANCE



MICHELIN AXIOBIB 2

FORTE CAPACITÉ DE TRACTION POUR CHARGES LOURDES



POUR TRACTEURS DE 160 À 550 CV



VF Très basse pression



PROTECTION DES SOLS

grâce à une basse pression jusqu'à 0,6 b



ADHÉRENCE accrue de +28 à +35%⁽¹⁾



MEILLEURE PRODUCTIVITÉ

+7 à +11%⁽¹⁾, Rendements +4%/an⁽²⁾



(1) Test effectué en interne, selon la dimension Comparaison MICHELIN AXIOBIB 2 VF 650/85 R42 vs MICHELIN MACHXBIB 650/85 R38
(2) Harper Adams University 2014/2016

DIMENSIONS

VF 540/65R30 158D/155E TL

VF 600/60R30 162D/159E TL

VF 600/70R30 168D/165E TL

VF 620/75R30 172D/169E TL

VF 650/60R34 168D/165E TL

VF 650/65R34 170D/167E TL

VF 710/60R34 173D/169E TL **NEW**

VF 650/60R38 170D/167E TL

VF 650/85R38 182D/179E TL

VF 800/70R38 187D/184E TL

VF 710/60R42 176D/173E TL

VF 650/65R42 174D/171E TL

VF 710/70R42 182D/179E TL

VF 710/75R42 184D/180E TL

VF 900/60R42 189D/185E TL **NEW**

VF 650/85R42 183D/180E TL

VF 750/70R44 186D/183E TL

MICHELIN AXIOBIB 2

Caractéristiques & Pression en bar / psi – Charges par pneu en kg*

Ø pouces	Description	CAI	e mm	D mm	R' mm	Cdr mm	Jante(s) recommandée(s)		Jante(s) tolérée(s)	Chambre à air (Code)	Volume interne 75% (litres)	Profond. de sculpture (mm)		
30	VF 540/65R30 158D/155E TL	296638	536	1460	641	4316	W18L		W16L (NRO)	754	332	48		
Bar	0.6	0.8	0.9	1	1.1	1.2	1.3	1.4	1.5	1.6	1.7	1.8	1.9	2
Psi	9	12	13	15	16	17	19	20	22	23	26	28	29	29
10 km/h	2400	2750	2940	3130	3320	3510	3695	3885	4075	4265	4370	4470	4575	4675
30 km/h	2225	2550	2725	2900	3075	3255	3430	3605	3780	3955	4050	4145	4240	4335
65 km/h	2180	2500	2670	2845	3015	3190	3360	3530	3705	3875	3970	4065	4155	4250
65 km/h Dual	1920	2180	2310	2440	2570	2700	2830	2960	3090	3220	3350	3480	3610	3740
70 km/h	2000	2330	2495	2655	2820	2985	3130	3270	3415	3555	3640	3730	3815	3900

Ø pouces	Description	CAI	e mm	D mm	R' mm	Cdr mm	Jante(s) recommandée(s)		Jante(s) tolérée(s)	Chambre à air (Code)	Volume interne 75% (litres)	Profond. de sculpture (mm)			
30	VF 600/60R30 162D/159E TL	371968	597	1468	643	4336	DW20B (A)		DW18L (NRO)	757	381	49			
Bar	0.4	0.6	0.8	0.9	1	1.1	1.2	1.3	1.4	1.5	1.6	1.7	1.8	1.9	2
Psi	6	9	12	13	15	16	17	19	20	22	23	25	26	28	29
10 km/h		2530	2965	3180	3395	3605	3820	4035	4250	4460	4675	4815	4950	5090	5225
30 km/h		2345	2750	2950	3145	3345	3545	3740	3940	4135	4335	4465	4590	4720	4845
65 km/h		2300	2695	2890	3085	3280	3475	3665	3860	4055	4250	4375	4500	4625	4750
65 km/h Dual	1715	2055	2390	2550	2715	2875	3035	3210	3390	3565	3740	3850	3960	4070	4180
70 km/h		2095	2445	2620	2790	2965	3140	3325	3505	3690	3870	3985	4100	4210	4325

Ø pouces	Description	CAI	e mm	D mm	R' mm	Cdr mm	Jante(s) recommandée(s)		Jante(s) tolérée(s)	Chambre à air (Code)	Volume interne 75% (litres)	Profond. de sculpture (mm)			
30	VF 600/70R30 168D/165E TL	426719	624	1579	689	4659	DW21B (A)		DW20B (A)	737	468	58			
Bar	0.4	0.6	0.8	0.9	1	1.1	1.2	1.3	1.4	1.5	1.6	1.7	1.8	1.9	2
Psi	6	9	12	13	15	16	17	19	20	22	23	25	26	28	29
10 km/h		3080	3575	3835	4100	4360	4620	4880	5145	5405	5665	5790	5915	6035	6160
30 km/h		2855	3315	3560	3800	4045	4285	4530	4770	5015	5255	5370	5485	5595	5710
65 km/h		2800	3250	3490	3725	3965	4200	4440	4675	4915	5150	5265	5375	5490	5600
65 km/h Dual	2075	2470	2860	3080	3300	3520	3740	3940	4135	4335	4530	4630	4730	4830	4930
70 km/h		2550	2990	3210	3430	3650	3870	4075	4280	4480	4685	4790	4890	4995	5095

* Se référer aux remarques en fin des tableaux de cette gamme

MICHELIN AXIOBIB 2

Caractéristiques & Pression en bar / psi – Charges par pneu en kg*

Ø pouces	Description	CAI	e mm	D mm	R' mm	Cdr mm	Jante(s) recommandée(s)		Jante(s) tolérée(s)	Chambre à air (Code)	Volume interne 75% (litres)	Profond. de sculpture (mm)		
30	VF 620/75R30 172D/169E TL	702894	662	1670	722	4919	DW23B (A)		DW20B (A) DW21B (A)	737	556	58		
Bar	0.6	0.8	0.9	1	1.1	1.2	1.3	1.4	1.5	1.6	1.7	1.8	1.9	2
Psi	9	12	13	15	16	17	19	20	22	23	26	28	29	29
10 km/h	3465	4015	4310	4605	4900	5200	5495	5790	6085	6380	6520	6655	6795	6930
30 km/h	3215	3725	4000	4275	4545	4820	5095	5370	5640	5915	6045	6170	6300	6425
65 km/h	3150	3650	3920	4190	4455	4725	4995	5265	5530	5800	5925	6050	6175	6300
65 km/h Dual	2770	3165	3365	3565	3760	3960	4160	4355	4555	4750	4950	5150	5345	5545
70 km/h	2890	3380	3625	3870	4115	4360	4600	4845	5085	5325	5440	5555	5670	5785

Ø pouces	Description	CAI	e mm	D mm	R' mm	Cdr mm	Jante(s) recommandée(s)		Jante(s) tolérée(s)	Chambre à air (Code)	Volume interne 75% (litres)	Profond. de sculpture (mm)			
34	VF 650/60R34 168D/165E TL	202185	677	1653	732	4895	DW23B (A)		DW21B (A) DW24B (A)	823	500	58			
Bar	0.4	0.6	0.8	0.9	1	1.1	1.2	1.3	1.4	1.5	1.6	1.7	1.8	1.9	2
Psi	6	9	12	13	15	16	17	19	20	22	23	25	26	28	29
10 km/h		3080	3565	3830	4090	4355	4615	4880	5140	5405	5665	5790	5915	6035	6160
30 km/h		2855	3305	3550	3795	4035	4280	4525	4770	5010	5255	5370	5485	5595	5710
65 km/h		2800	3240	3480	3720	3955	4195	4435	4675	4910	5150	5265	5375	5490	5600
65 km/h Dual	2025	2445	2860	3055	3245	3440	3630	3855	4080	4305	4530	4630	4730	4830	4930
70 km/h		2580	2985	3190	3395	3595	3800	4035	4275	4510	4745	4845	4950	5050	5150

Ø pouces	Description	CAI	e mm	D mm	R' mm	Cdr mm	Jante(s) recommandée(s)		Jante(s) tolérée(s)	Chambre à air (Code)	Volume interne 75% (litres)	Profond. de sculpture (mm)			
34	VF 650/65R34 170D/167E TL	101906	679	1710	756	5061	DW23B (A)		DW21B (A)	823	600	58			
Bar	0.4	0.6	0.8	0.9	1	1.1	1.2	1.3	1.4	1.5	1.6	1.7	1.8	1.9	2
Psi	6	9	12	13	15	16	17	19	20	22	23	25	26	28	29
10 km/h		3385	3950	4205	4460	4715	4975	5230	5485	5740	5995	6145	6300	6450	6600
30 km/h		3135	3660	3900	4135	4375	4610	4850	5085	5325	5560	5700	5840	5980	6120
65 km/h		3075	3590	3825	4055	4290	4520	4755	4985	5220	5450	5590	5725	5865	6000
65 km/h Dual	2265	2695	3125	3360	3600	3835	4070	4250	4435	4615	4795	4915	5040	5160	5280
70 km/h		2830	3305	3545	3785	4020	4260	4450	4640	4830	5020	5145	5275	5400	5525

* Se référer aux remarques en fin des tableaux de cette gamme

MICHELIN AXIOBIB 2

Caractéristiques & Pression en bar / psi – Charges par pneu en kg*

Ø pouces	Description	CAI	e mm	D mm	R' mm	Cdr mm	Jante(s) recommandée(s)	Jante(s) tolérée(s)	Chambre à air (Code)	Volume interne 75% (litres)	Profond. de sculpture (mm)				
34	VF 710/60R34 173D/169E TL NEW	757609	731	1727	754	5093	DW25B (A)	DW23B (A) (NRO) MW25B (A)		613	58				
Bar	0.4	0.6	0.8	0.9	1	1.1	1.2	1.3	1.4	1.5	1.6	1.7	1.8	1.9	2
Psi	6	9	12	13	15	16	17	19	20	22	23	25	26	28	29
10 km/h	3465	4125	4405	4690	4970	5255	5535	5815	6100	6380	6575	6765	6960	7150	
30 km/h	3215	3825	4085	4350	4610	4870	5130	5395	5655	5915	6095	6275	6450	6630	
65 km/h	3150	3750	4005	4265	4520	4775	5030	5290	5545	5800	5975	6150	6325	6500	
65 km/h Dual	2330	2815	3300	3520	3740	3960	4180	4410	4645	4875	5105	5260	5415	5565	5720
70 km/h	2865	3350	3595	3840	4080	4325	4565	4805	5040	5280	5410	5540	5670	5800	

Ø pouces	Description	CAI	e mm	D mm	R' mm	Cdr mm	Jante(s) recommandée(s)	Jante(s) tolérée(s)	Chambre à air (Code)	Volume interne 75% (litres)	Profond. de sculpture (mm)				
38	VF 650/60R38 170D/167E TL	908973	668	1742	772	5145	DW23B (A)	DW20B (A) (NRO) MW23B (A)	825	540	58				
Bar	0.4	0.6	0.8	0.9	1	1.1	1.2	1.3	1.4	1.5	1.6	1.7	1.8	1.9	2
Psi	6	9	12	13	15	16	17	19	20	22	23	25	26	28	29
10 km/h	3190	3795	4050	4305	4560	4815	5065	5320	5575	5830	6025	6215	6410	6600	
30 km/h	2960	3520	3755	3990	4225	4465	4700	4935	5170	5405	5585	5765	5940	6120	
65 km/h	2900	3450	3680	3915	4145	4375	4605	4840	5070	5300	5475	5650	5825	6000	
65 km/h Dual	2140	2590	3035	3240	3445	3645	3850	4055	4260	4460	4665	4820	4975	5125	5280
70 km/h	2640	3085	3310	3535	3755	3980	4190	4405	4615	4825	4985	5145	5300	5460	

Ø pouces	Description	CAI	e mm	D mm	R' mm	Cdr mm	Jante(s) recommandée(s)	Jante(s) tolérée(s)	Chambre à air (Code)	Volume interne 75% (litres)	Profond. de sculpture (mm)				
38	VF 650/85R38 182D/179E TL	655949	680	2063	900	6088	DW23B (A)	DW20B (A) DW21B	804	857	63				
Bar	0.4	0.6	0.8	0.9	1	1.1	1.2	1.3	1.4	1.5	1.6	1.7	1.8	1.9	2
Psi	6	9	12	13	15	16	17	19	20	22	23	25	26	28	29
10 km/h	4675	5365	5760	6155	6550	6945	7340	7735	8130	8525	8730	8940	9145	9350	
30 km/h	4335	4975	5340	5710	6075	6440	6805	7175	7540	7905	8095	8290	8480	8670	
65 km/h	4250	4875	5235	5595	5955	6315	6670	7030	7390	7750	7940	8125	8315	8500	
65 km/h Dual	3125	3710	4290	4605	4920	5230	5545	5865	6185	6500	6820	6985	7150	7315	7480
70 km/h	3870	4490	4805	5115	5425	5735	6065	6395	6725	7055	7230	7405	7575	7750	

* Se référer aux remarques en fin des tableaux de cette gamme

MICHELIN AXIOBIB 2

Caractéristiques & Pression en bar / psi – Charges par pneu en kg*

Ø pouces	Description	CAI	e mm	D mm	R' mm	Cdr mm	Jante(s) recommandée(s)	Jante(s) tolérée(s)	Chambre à air (Code)	Volume interne 75% (litres)	Profond. de sculpture (mm)				
38	VF 800/70R38 187D/184E TL	136377	821	2072	891	6096	DW27B (A)	DW25B (A)	804	1073	63				
Bar	0.4	0.6	0.8	0.9	1	1.1	1.2	1.3	1.4	1.5	1.6	1.7	1.8	1.9	2
Psi	6	9	12	13	15	16	17	19	20	22	23	25	26	28	29
10 km/h	5365	6380	6820	7260	7700	8140	8580	9020	9460	9900	10105	10315	10520	10725	
30 km/h	4975	5915	6325	6730	7140	7550	7955	8365	8770	9180	9370	9565	9755	9945	
65 km/h	4875	5800	6200	6600	7000	7400	7800	8200	8600	9000	9190	9375	9565	9750	
65 km/h Dual	3630	4370	5105	5435	5765	6095	6425	6800	7175	7545	7920	8085	8250	8415	8580
70 km/h	4435	5170	5540	5910	6275	6645	7030	7420	7805	8190	8395	8595	8800	9000	

Ø pouces	Description	CAI	e mm	D mm	R' mm	Cdr mm	Jante(s) recommandée(s)	Jante(s) tolérée(s)	Chambre à air (Code)	Volume interne 75% (litres)	Profond. de sculpture (mm)				
42	VF 710/60R42 176D/173E TL	941770	730	1885	830	5574	DW25B (A)	DW23B (A) (NRO) MW25B (A)	802	710	58				
Bar	0.4	0.6	0.8	0.9	1	1.1	1.2	1.3	1.4	1.5	1.6	1.7	1.8	1.9	2
Psi	6	9	12	13	15	16	17	19	20	22	23	25	26	28	29
10 km/h	3795	4540	4865	5195	5520	5845	6170	6495	6825	7150	7315	7480	7645	7810	
30 km/h	3520	4210	4515	4815	5120	5420	5725	6025	6330	6630	6785	6935	7090	7240	
65 km/h	3450	4125	4420	4720	5015	5315	5610	5905	6205	6500	6650	6800	6950	7100	
65 km/h Dual	2550	3090	3630	3890	4150	4405	4665	4930	5195	5455	5720	5855	5985	6120	6250
70 km/h	3140	3700	3985	4265	4545	4825	5100	5370	5645	5915	6050	6190	6325	6460	

Ø pouces	Description	CAI	e mm	D mm	R' mm	Cdr mm	Jante(s) recommandée(s)	Jante(s) tolérée(s)	Chambre à air (Code)	Volume interne 75% (litres)	Profond. de sculpture (mm)				
42	VF 650/65R42 174D/171E TL	387916	666	1920	847	5680	DW23B (A)	DW20B (A) (NRO) DW21B(A)	802	643	58				
Bar	0.4	0.6	0.8	0.9	1	1.1	1.2	1.3	1.4	1.5	1.6	1.7	1.8	1.9	2
Psi	6	9	12	13	15	16	17	19	20	22	23	25	26	28	29
10 km/h	3685	4400	4675	4950	5225	5500	5775	6050	6325	6600	6795	6985	7180	7370	
30 km/h	3415	4080	4335	4590	4845	5100	5355	5610	5865	6120	6300	6480	6655	6835	
65 km/h	3350	4000	4250	4500	4750	5000	5250	5500	5750	6000	6175	6350	6525	6700	
65 km/h Dual	2465	2995	3520	3740	3960	4180	4400	4620	4840	5060	5280	5435	5590	5740	5895
70 km/h	3075	3580	3835	4085	4340	4590	4820	5050	5275	5505	5665	5830	5990	6150	

* Se référer aux remarques en fin des tableaux de cette gamme

MICHELIN AXIOBIB 2

Caractéristiques & Pression en bar / psi – Charges par pneu en kg*

Ø pouces	Description	CAI	e mm	D mm	R' mm	Cdr mm	Jante(s) recommandée(s)		Jante(s) tolérée(s)	Chambre à air (Code)	Volume interne 75% (litres)	Profond. de sculpture (mm)			
42	VF 710/70R42 182D/179E TL	523668	731	2066	906	6104	DW25B (A)		DW23B (A) MW25B (A)	802	867	63			
Bar	0.4	0.6	0.8	0.9	1	1.1	1.2	1.3	1.4	1.5	1.6	1.7	1.8	1.9	2
Psi	6	9	12	13	15	16	17	19	20	22	25	26	28	29	
10 km/h		4675	5500	5880	6255	6635	7015	7390	7770	8145	8525	8730	8940	9145	9350
30 km/h		4335	5100	5450	5800	6150	6505	6855	7205	7555	7905	8095	8290	8480	8670
65 km/h		4250	5000	5345	5690	6030	6375	6720	7065	7405	7750	7940	8125	8315	8500
65 km/h Dual	3125	3765	4400	4685	4975	5260	5545	5865	6185	6500	6820	6985	7150	7315	7480
70 km/h		3870	4490	4805	5115	5425	5735	6065	6395	6725	7055	7230	7405	7575	7750

Ø pouces	Description	CAI	e mm	D mm	R' mm	Cdr mm	Jante(s) recommandée(s)		Jante(s) tolérée(s)	Chambre à air (Code)	Volume interne 75% (litres)	Profond. de sculpture (mm)			
42	VF 710/75R42 184D/180E TL	259635	737	2153	950	6370	DW25B (A)		DW23B (A)	802	945	65			
Bar	0.4	0.6	0.8	0.9	1	1.1	1.2	1.3	1.4	1.5	1.6	1.7	1.8	1.9	2
Psi	6	9	12	13	15	16	17	19	20	22	23	25	26	28	29
10 km/h		4950	5760	6175	6590	7005	7420	7830	8245	8660	9075	9280	9490	9695	9900
30 km/h		4590	5340	5725	6110	6495	6880	7260	7645	8030	8415	8605	8800	8990	9180
65 km/h		4500	5235	5610	5990	6365	6745	7120	7495	7875	8250	8440	8625	8815	9000
65 km/h Dual	3300	3985	4665	4975	5280	5590	5895	6235	6580	6920	7260	7425	7590	7755	7920
70 km/h		4145	4820	5160	5495	5835	6170	6530	6885	7245	7600	7700	7800	7900	8000

Ø pouces	Description	CAI	e mm	D mm	R' mm	Cdr mm	Jante(s) recommandée(s)		Jante(s) tolérée(s)	Chambre à air (Code)	Volume interne 75% (litres)	Profond. de sculpture (mm)			
42	VF 900/60R42 189D/185E TL NEW	428922	881	2158	942	6357	DW30B (A)		DW28B (A) (NRO)		1230	64			
Bar	0.4	0.6	0.8	0.9	1	1.1	1.2	1.3	1.4	1.5	1.6	1.7	1.8	1.9	2
Psi	6	9	12	13	15	16	17	19	20	22	23	25	26	28	29
10 km/h		5550	6475	6940	7400	7865	8325	8790	9250	9715	10175	10465	10755	11040	11330
30 km/h		5145	6005	6435	6865	7290	7720	8150	8580	9005	9435	9705	9970	10240	10505
65 km/h		5045	5885	6305	6725	7145	7565	7985	8410	8830	9250	9515	9775	10040	10300
65 km/h Dual	3665	4440	5180	5550	5920	6290	6660	7030	7400	7770	8140	8370	8605	8835	9065
70 km/h		4590	5355	5740	6120	6505	6885	7270	7655	8035	8420	8630	8835	9045	9250

* Se référer aux remarques en fin des tableaux de cette gamme

MICHELIN AXIOBIB 2

Caractéristiques & Pression en bar / psi – Charges par pneu en kg*

Ø pouces	Description	CAI	e mm	D mm	R' mm	Cdr mm	Jante(s) recommandée(s)		Jante(s) tolérée(s)	Chambre à air (Code)	Volume interne 75% (litres)	Profond. de sculpture (mm)		
42	VF 650/85R42 183D/180E TL	530764	670	2164	948	6393	DW23B (A)		DW21B(A)	802	914	61		
Bar	0.6	0.8	0.9	1	1.1	1.2	1.3	1.4	1.5	1.6	1.7	1.8	1.9	2
Psi	9	12	13	15	16	17	19	20	22	23	26	28	28	29
10 km/h	4815	5665	6055	6450	6840	7235	7625	8015	8410	8800	9005	9215	9420	9625
30 km/h	4465	5255	5620	5980	6345	6710	7070	7435	7795	8160	8350	8545	8735	8925
65 km/h	4375	5150	5505	5865	6220	6575	6930	7290	7645	8000	8190	8375	8565	8750
65 km/h Dual	3850	4400	4675	4950	5225	5500	5775	6050	6325	6600	6875	7150	7425	7700
70 km/h	4015	4665	4990	5315	5640	5965	6310	6655	7000	7345	7515	7690	7860	8030

Ø pouces	Description	CAI	e mm	D mm	R' mm	Cdr mm	Jante(s) recommandée(s)		Jante(s) tolérée(s)	Chambre à air (Code)	Volume interne 75% (litres)	Profond. de sculpture (mm)			
44	VF 750/70R44 186D/183E TL	681569	763	2180	956	6438	DW25B (A)		MW25B (A) MW24B (A) DW24B (A)		1016	64			
Bar	0.4	0.6	0.8	0.9	1	1.1	1.2	1.3	1.4	1.5	1.6	1.7	1.8	1.9	2
Psi	6	9	12	13	15	16	17	19	20	22	23	25	26	28	29
10 km/h		5225	6090	6530	6975	7415	7860	8300	8740	9185	9625	9830	10040	10245	10450
30 km/h		4845	5645	6055	6465	6875	7285	7695	8105	8515	8925	9115	9310	9500	9690
65 km/h		4750	5535	5935	6340	6740	7145	7545	7945	8350	8750	8940	9125	9315	9500
65 km/h Dual	3410	4105	4795	5160	5525	5885	6250	6615	6975	7340	7700	7865	8030	8195	8360
70 km/h		4375	5095	5460	5820	6180	6540	6920	7300	7680	8060	8235	8405	8580	8750

***REMARQUES**

La pression de gonflage se détermine toujours en fonction de la charge par pneu, de la vitesse et du travail à réaliser.
 Nos préconisations ci-dessus sont fournies sous réserve de modifications postérieures à la date de diffusion de ces tableaux (mars 2021).
 Les données techniques sont susceptibles d'évoluer sans information préalable.

- Pour un usage labour et d'autres usages champ sous couple élevé, utiliser la ligne 30 km/h.
- Lors d'un usage en monte simple :
 - Pour usage en dévers >20% : ajouter 0,4 bar.
 - Pour usage routier intensif >50% : ajouter 0,4 bar.
- (NRO) - Narrow Rim Option. Ajouter 0,2 bar en cas de montage sur une jante NRO.



MICHELIN AXIOBIB

**TRACTION & PROTECTION
DU SOL AMÉLIORÉE POUR
TRACTEURS DE TRÈS FORTE
PUISSANCE**



POUR TRACTEUR DE FORTE PUISSANCE 250 CV ET PLUS



NORME IF

jusqu'à 0,8 b de pression en moins ou jusqu'à 2500 kg de charge supplémentaire à l'essieu à iso-pression par rapport à un normal flex



MEILLEURS RENDEMENTS

4%/an⁽¹⁾



ÉCONOMIES DE CARBURANT

jusqu'à **15%** d'économie aux champs⁽²⁾



+11% D'ADHÉRENCE avec l'AXIOBIB IF 710/70R42 par rapport à un 710/70R42 standard



PROTECTION DES SOLS

grâce à une basse pression jusqu'à 0,8 b

(1) Harper Adams University 2014/2016

(2) Moyenne observée en comparaison avec une dimension standard lors de tests sur surfaces agricoles

DIMENSIONS

IF 600/70R30 159D TL

IF 620/75R30 164D TL

IF 650/75R30 166D TL

IF 650/60R34 165D TL

IF 710/60R34 164D TL

IF 650/65R34 161D TL

IF 650/65R38 169D TL

IF 710/60R38 172D TL

IF 650/85R38 179D TL

IF 800/70R38 179D TL

IF 710/85R38 178D TL

IF 710/70R42 179D TL

IF 900/60R42 186D TL

IF 710/75R42 176D TL

IF 750/75R46 186D TL

IF 900/65R46 190D TL

MICHELIN AXIOBIB

Caractéristiques & Pression en bar / psi – Charges par pneu en kg*

Ø pouces	Description	CAI	e mm	D mm	R' mm	Cdr. mm	Jante(s) recommandée(s)	Jante(s) tolérée(s)	Chambre à air (Code)	Volume interne 75% (litres)	Profond. de sculpture (mm)
30	IF 600/70R30 159D TL	280086	613	1585	695	4683	DW21B (A)	DW20B (A)	737	450	56
Bar	0.4 0.6 0.8 1 1.2 1.4 1.6										
Psi	6 9 12 15 17 20 23										
10 km/h		3220	3710	4200	4615	5030					
30 km/h		2910	3355	3795	4175	4550					
65 km/h		2800	3225	3650	4015	4375					
65 km/h Dual	1760 2110	2460	2835	3210	3530	3850					

Ø pouces	Description	CAI	e mm	D mm	R' mm	Cdr. mm	Jante(s) recommandée(s)	Jante(s) tolérée(s)	Chambre à air (Code)	Volume interne 75% (litres)	Profond. de sculpture (mm)
30	IF 620/75R30 164D TL	668406	659	1670	728	4927	DW23B (A)	DW21B (A) MW23B(A)	737	570	58
Bar	0.4 0.6 0.8 1 1.2 1.4 1.6										
Psi	6 9 12 15 17 20 23										
10 km/h		3620	4110	4600	5175	5750					
30 km/h		3275	3720	4160	4680	5200					
65 km/h		3150	3575	4000	4500	5000					
65 km/h Dual	1970 2370	2770	3145	3520	3960	4400					

Ø pouces	Description	CAI	e mm	D mm	R' mm	Cdr. mm	Jante(s) recommandée(s)	Jante(s) tolérée(s)	Chambre à air (Code)	Volume interne 75% (litres)	Profond. de sculpture (mm)
30	IF 650/75R30 166D TL	828322	679	1721	745	5071	DW23B (A)	MW23B(A)		638	57
Bar	0.4 0.6 0.8 1 1.2 1.4 1.6										
Psi	6 9 12 15 17 20 23										
10 km/h		3965	4500	5030	5565	6095					
30 km/h		3590	4070	4550	5030	5510					
65 km/h		3450	3915	4375	4840	5300					
65 km/h Dual	2140 2590	3040	3445	3850	4255	4660					

Ø pouces	Description	CAI	e mm	D mm	R' mm	Cdr. mm	Jante(s) recommandée(s)	Jante(s) tolérée(s)	Chambre à air (Code)	Volume interne 75% (litres)	Profond. de sculpture (mm)			
34	IF 650/60R34 165D TL	100511	633	1661	745	4933	DW23B (A)	DW21B (A) DW24B (A)	823	500	58			
Bar	0.4 0.6 0.8 1 1.2 1.4 1.6 1.7 1.8 1.9 2 2.1 2.2 2.3 2.4													
Psi	6 9 12 15 17 20 23 25 26 28 29 30 32 33 35													
10 km/h		3220	3675	4130	4580	5030	5145	5255	5370	5480	5590	5700	5810	5920
30 km/h		2910	3325	3735	4145	4550	4650	4755	4855	4955	5055	5155	5255	5355
65 km/h		2800	3195	3590	3985	4375	4475	4570	4670	4765	4860	4960	5055	5150
65 km/h Dual	1760 2115	2465	2815	3160	3505	3850	3935	4020	4105	4190	4275	4360	4445	4530

* Se référer aux remarques en fin des tableaux de cette gamme

MICHELIN AXIOBIB

Caractéristiques & Pression en bar / psi – Charges par pneu en kg*

Ø pouces	Description	CAI	e mm	D mm	R' mm	Cdr mm	Jante(s) recommandée(s)	Jante(s) tolérée(s)	Chambre à air (Code)	Volume interne 75% (litres)	Profond. de sculpture (mm)
34	IF 710/60R34 164D TL	712503	708	1696	756	5030	DW25B (A)			615	58
Bar	0.4 0.6 0.8 1 1.2 1.4 1.6										
Psi	6 9 12 15 17 20 23										
10 km/h		3620	4185	4745	5250	5750					
30 km/h		3275	3785	4290	4745	5200					
65 km/h		3150	3640	4125	4565	5000					
65 km/h Dual	1970 2370	2770	3200	3630	4015	4400					

Ø pouces	Description	CAI	e mm	D mm	R' mm	Cdr mm	Jante(s) recommandée(s)	Jante(s) tolérée(s)	Chambre à air (Code)	Volume interne 75% (litres)	Profond. de sculpture (mm)
34	IF 650/65R34 161D TL	711975	653	1721	764	5099	DW23B (A)		823	555	58
Bar	0.4 0.6 0.8 1 1.2 1.4 1.6										
Psi	6 9 12 15 17 20 23										
10 km/h		3535	4070	4600	4960	5320					
30 km/h		3200	3680	4160	4485	4810					
65 km/h		3075	3540	4000	4315	4625					
65 km/h Dual	1920 2315	2710	3115	3520	3795	4070					

Ø pouces	Description	CAI	e mm	D mm	R' mm	Cdr mm	Jante(s) recommandée(s)	Jante(s) tolérée(s)	Chambre à air (Code)	Volume interne 75% (litres)	Profond. de sculpture (mm)			
38	IF 650/65R38 169D TL	508421	649	1826	833	5446	DW23B (A)	MW21B(A) DW21B (A)	825	599	58			
Bar	0.4 0.6 0.8 1 1.2 1.4 1.6 1.7 1.8 1.9 2 2.1 2.2 2.3 2.4													
Psi	6 9 12 15 17 20 23 25 26 28 29 30 32 33 35													
10 km/h		3735	4240	4745	5175	5605	5740	5875	6005	6140	6275	6405	6540	6670
30 km/h		3380	3835	4290	4680	5070	5190	5315	5435	5555	5675	5795	5910	6030
65 km/h		3250	3690	4125	4500	4875	4990	5110	5225	5340	5455	5570	5685	5800
65 km/h Dual	2025 2445	2860	3245	3630	3960	4290	4390	4495	4595	4695	4795	4900	5000	5100

Ø pouces	Description	CAI	e mm	D mm	R' mm	Cdr mm	Jante(s) recommandée(s)	Jante(s) tolérée(s)	Chambre à air (Code)	Volume interne 75% (litres)	Profond. de sculpture (mm)			
38	IF 710/60R38 172D TL	220975	710	1844	834	5486	DW25B (A)		825	661	58			
Bar	0.4 0.6 0.8 1 1.2 1.4 1.6 1.7 1.8 1.9 2 2.1 2.2 2.3 2.4													
Psi	6 9 12 15 17 20 23 25 26 28 29 30 32 33 35													
10 km/h		3850	4415	4975	5535	6095	6240	6385	6525	6670	6815	6960	7100	7245
30 km/h		3485	3995	4500	5005	5510	5640	5770	5900	6030	6160	6290	6420	6550
65 km/h		3350	3840	4325	4815	5300	5425	5550	5675	5800	5925	6050	6175	6300
65 km/h Dual	2360 2680	3000	3410	3815	4220	4625	4740	4855	4970	5085	5200	5315	5430	5545

* Se référer aux remarques en fin des tableaux de cette gamme

MICHELIN AXIOBIB

Caractéristiques & Pression en bar / psi – Charges par pneu en kg*

Ø pouces	Description	CAI	e mm	D mm	R' mm	Cdr mm	Jante(s) recommandée(s)	Jante(s) tolérée(s)	Chambre à air (Code)	Volume interne 75% (litres)	Profond. de sculpture (mm)			
38	IF 650/85R38 179D TL	084900	692	2050	913	6078	DW23B (A)	MW23B (A)	804	900	63			
Bar	0.4 0.6 0.8 1 1.2 1.4 1.6 1.7 1.8 1.9 2 2.1 2.2 2.3 2.4													
Psi	6 9 12 15 17 20 23 25 26 28 29 30 32 33 35													
10 km/h		4890	5580	6265	6985	7705	7880	8050	8225	8395	8525	8655	8785	8915
30 km/h		4420	5045	5670	6320	6970	7125	7280	7435	7590	7710	7825	7945	8060
65 km/h		4250	4850	5450	6075	6700	6850	7000	7150	7300	7415	7525	7640	7750
65 km/h Dual	2640 3190	3740	4270	4800	5350	5900	6030	6160	6290	6420	6520	6620	6720	6820

Ø pouces	Description	CAI	e mm	D mm	R' mm	Cdr mm	Jante(s) recommandée(s)	Jante(s) tolérée(s)	Chambre à air (Code)	Volume interne 75% (litres)	Profond. de sculpture (mm)
38	IF 800/70R38 179D TL	528166	810	2067	894	6089	DW27B (A)		804	1088	63
Bar	0.4 0.6 0.8 1 1.2 1.4 1.6										
Psi	6 9 12 15 17 20 23										
10 km/h		5605	6425	7245	8080	8915					
30 km/h		5070	5810	6550	7305	8060					
65 km/h		4875	5590	6300	7025	7750					
65 km/h Dual	3040 3665	4290	4915	5540	6180	6820					

Ø pouces	Description	CAI	e mm	D mm	R' mm	Cdr mm	Jante(s) recommandée(s)	Jante(s) tolérée(s)	Chambre à air (Code)	Volume interne 75% (litres)	Profond. de sculpture (mm)
38	IF 710/85R38 178D TL	992951	734	2159	937	6365	DW25B (A)	MW25B (A)	804	1088	65
Bar	0.4 0.6 0.8 1 1.2 1.4 1.6										
Psi	6 9 12 15 17 20 23										
10 km/h		5605	6340	7070	7850	8625					
30 km/h		5070	5735	6395	7100	7800					
65 km/h		4875	5515	6150	6825	7500					
65 km/h Dual	3040 3665	4290	4850	5410	6005	6600					

Ø pouces	Description	CAI	e mm	D mm	R' mm	Cdr mm	Jante(s) recommandée(s)	Jante(s) tolérée(s)	Chambre à air (Code)	Volume interne 75% (litres)	Profond. de sculpture (mm)			
42	IF 710/70R42 179D TL	771752	742	2062	919	6115	DW25B (A)	MW25B (A) DW23B	802	870	63			
Bar	0.4 0.6 0.8 1 1.2 1.4 1.6 1.7 1.8 1.9 2 2.1 2.2 2.3 2.4													
Psi	6 9 12 15 17 20 23 25 26 28 29 30 32 33 35													
10 km/h		4890	5580	6265	6985	7705	7880	8050	8225	8395	8525	8655	8785	8915
30 km/h		4420	5045	5670	6320	6970	7125	7280	7435	7590	7710	7825	7945	8060
65 km/h		4250	4850	5450	6075	6700	6850	7000	7150	7300	7415	7525	7640	7750
65 km/h Dual	2640 3190	3740	4270	4800	5350	5900	6030	6160	6290	6420	6520	6620	6720	6820

* Se référer aux remarques en fin des tableaux de cette gamme

MICHELIN AXIOBIB

Caractéristiques & Pression en bar / psi – Charges par pneu en kg*

Ø pouces	Description	CAI	e mm	D mm	R' mm	Cdr mm	Jante(s) recommandée(s)	Jante(s) tolérée(s)	Chambre à air (Code)	Volume interne 75% (litres)	Profond. de sculpture (mm)				
42	IF 900/60R42 186D TL	111950	881	2123	952	6304	DW30B (A)			1230	65				
Bar	0.4	0.6	0.8	1	1.2	1.4	1.6	1.7	1.8	1.9	2	2.1	2.2	2.3	2.4
Psi	6	9	12	15	17	20	23	25	26	28	29	30	32	33	35
10 km/h			5750	6615	7475	8340	9200	9415	9635	9850	10065	10280	10495	10710	10925
30 km/h			5200	5980	6760	7540	8320	8515	8710	8905	9100	9295	9490	9685	9880
65 km/h			5000	5750	6500	7250	8000	8190	8375	8565	8750	8940	9125	9315	9500
65 km/h Dual	3210	3805	4400	5060	5720	6380	7040	7205	7370	7535	7700	7865	8030	8195	8360

Ø pouces	Description	CAI	e mm	D mm	R' mm	Cdr mm	Jante(s) recommandée(s)	Jante(s) tolérée(s)	Chambre à air (Code)	Volume interne 75% (litres)	Profond. de sculpture (mm)
42	IF 710/75R42 176D TL	037489	715	2161	954	6395	DW25B (A)		802	953	66
Bar	0.4	0.6	0.8	1	1.2	1.4	1.6				
Psi	6	9	12	15	17	20	23				
10 km/h			5190	5935	6680	7425	8165				
30 km/h			4695	5370	6040	6715	7385				
65 km/h			4515	5165	5810	6455	7100				
65 km/h Dual	2845	3415	3980	4550	5115	5685	6250				

Ø pouces	Description	CAI	e mm	D mm	R' mm	Cdr mm	Jante(s) recommandée(s)	Jante(s) tolérée(s)	Chambre à air (Code)	Volume interne 75% (litres)	Profond. de sculpture (mm)				
46	IF 710/75R46 186D TL	487001	761	2287	1043	6819	DW25B (A)			1147	71				
Bar	0.4	0.6	0.8	1	1.2	1.4	1.6	1.7	1.8	1.9	2	2.1	2.2	2.3	2.4
Psi	6	9	12	15	17	20	23	25	26	28	29	30	32	33	35
10 km/h			5920	6700	7475	8340	9200	9415	9635	9850	10065	10280	10495	10710	10925
30 km/h			5355	6060	6760	7540	8320	8515	8710	8905	9100	9295	9490	9685	9880
65 km/h			5150	5825	6500	7250	8000	8190	8375	8565	8750	8940	9125	9315	9500
65 km/h Dual	3210	3870	4530	5125	5720	6380	7040	7205	7370	7535	7700	7865	8030	8195	8360

Ø pouces	Description	CAI	e mm	D mm	R' mm	Cdr mm	Jante(s) recommandée(s)	Jante(s) tolérée(s)	Chambre à air (Code)	Volume interne 75% (litres)	Profond. de sculpture (mm)				
46	IF 900/65R46 190D TL	162365	915	2322	1038	6888	MW30B (A)			1450	71				
Bar	0.4	0.6	0.8	1	1.2	1.4	1.6	1.7	1.8	1.9	2	2.1	2.2	2.3	2.4
Psi	6	9	12	15	17	20	23	25	26	28	29	30	32	33	35
10 km/h			6670	7650	8625	9345	10065	10330	10595	10860	11125	11390	11660	11925	12190
30 km/h			6030	6915	7800	8450	9100	9340	9580	9820	10060	10300	10545	10785	11025
65 km/h			5800	6650	7500	8125	8750	8980	9215	9445	9675	9905	10140	10370	10600
65 km/h Dual	3630	4370	5105	5855	6600	7150	7700	7905	8110	8310	8515	8720	8925	9125	9330

* Se référer aux remarques en fin des tableaux de cette gamme

MICHELIN AXIOBIB

Caractéristiques & Pression en bar / psi – Charges par pneu en kg*

*REMARQUES

La pression de gonflage se détermine toujours en fonction de la charge par pneu, de la vitesse et du travail à réaliser.

Nos préconisations ci-dessus sont fournies sous réserve de modifications postérieures à la date de diffusion de ces tableaux (mars 2021).

Les données techniques sont susceptibles d'évoluer sans information préalable.

• Pour un usage labour et d'autres usages champ sous couple élevé, utiliser la ligne 30 km/h.

• Lors d'un usage en monte simple :

- Pour usage en dévers >20% : ajouter 0,4 bar.

- Pour usage routier intensif >50% : ajouter 0,4 bar.



MICHELIN MACHXBIB

**ÉCONOMIE & POLYVALENCE
GARANTIES
POUR TRACTEURS
DE FORTE PUISSANCE**



POUR TRACTEUR DE FORTE PUISSANCE 160 CV ET PLUS



POLYVALENT

idéal pour les trajets routiers et efficace dans les champs :

- Vitesse jusqu'à 65km/h⁽¹⁾
- capacité de charges dans les champs
- résistance aux dommages



4% d'économies de carburants, 1 litre/h par rapport au principal concurrent (pour une consommation sur route de 25 l/h) ⁽²⁾



Endurance de la carcasse éprouvée



(1) Lorsque autorisé par les lois du pays- selon la dimension

(2) Test d'analyse piste centre d'essais MICHELIN de Ladoux

DIMENSIONS

600/65R28 154A8/154B TL

600/65R28 154D/150E TL **NEW**

600/65R28 154D TL

600/70R28 157D/154E TL **NEW**

600/70R28 157A8/157B TL

710/55R30 153D TL

600/70R30 158D TL **NEW**

600/70R30 152D TL

680/75R32 164A8/161B TL

650/60R34 159D/155E TL

650/65R34 161D/157E TL

650/75R38 169A8/169B TL

710/70R38 171D TL

650/85R38 173A8/173B TL

800/70R38 173D TL

900/50R42 168D TL

710/70R42 173D TL

710/75R42 175D/171E TL

620/70R46 162D TL **NEW**

620/70R46 162A8/162B TL

MICHELIN MACHXBIB

Caractéristiques & Pression en bar / psi – Charges par pneu en kg*

Ø pouces	Description	CAI	e mm	D mm	R' mm	Cdr mm	Jante(s) recommandée(s)		Jante(s) tolérée(s)	Chambre à air (Code)	Volume interne 75% (litres)	Profond. de sculpture (mm)	
28	600/65R28 154A8/154B TL	135288	615	1485	669	4415	DW20B (A)		DW18L W18L	717	425	51	
Bar	0.4	0.6	0.8	1	1.2	1.4	1.6	1.7	1.8	1.9	2	2.2	2.4
Psi	6	9	12	15	17	20	23	25	26	28	29	32	35
10 km/h				3150	3505	3855	4210	4390	4565	4745	4920	5275	5630
25 km/h				2610	2925	3245	3560	3635	3710	3785	3860	4010	4160
30 km/h	1610	1915	2215	2520	2825	3125	3430	3505	3575	3650	3720	3865	4010
40 km/h				2490	2710	2930	3150	3225	3300	3375	3450	3600	3750
40 km/h Dual	1320	1610	1900	2190	2385	2575	2770	2835	2905	2970	3035	3170	3300
50 km/h					2710	2930	3150	3225	3300	3375	3450	3600	3750

Ø pouces	Description	CAI	e mm	D mm	R' mm	Cdr mm	Jante(s) recommandée(s)		Jante(s) tolérée(s)	Chambre à air (Code)	Volume interne 75% (litres)	Profond. de sculpture (mm)			
28	600/65R28 154D/150E TL NEW	429970	626	1494	671	4465	DW20B (A)		DW18L W18L DW21B(A)	717	405	54			
Bar	0.4	0.6	0.8	1	1.2	1.4	1.6	1.7	1.8	1.9	2	2.2	2.4	2.6	2.8
Psi	6	9	12	15	17	20	23	25	26	28	29	32	35	38	41
10 km/h	2250	2530	2810	3090	3445	3805	4160	4340	4520	4695	4875	5065	5250	5440	5625
30 km/h	1725	2040	2360	2675	2990	3310	3625	3710	3800	3885	3970	4145	4315		
40 km/h		1915	2220	2530	2835	3145	3450	3530	3615	3695	3780	3940	4105		
40 km/h Dual	1445	1710	1975	2240	2505	2770	3035	3110	3180	3255	3325	3470	3615		
50 km/h		1840	2135	2430	2720	3015	3310	3390	3470	3545	3625	3785	3940		
65 km/h			2060	2335	2605	2880	3150	3225	3300	3375	3450	3600	3750		
70 km/h			1875	2125	2375	2620	2870	2930	2990	3050	3110	3230	3350		

Ø pouces	Description	CAI	e mm	D mm	R' mm	Cdr mm	Jante(s) recommandée(s)		Jante(s) tolérée(s)	Chambre à air (Code)	Volume interne 75% (litres)	Profond. de sculpture (mm)			
28	600/65R28 154D TL	055335	615	1502	666	4449	DW20B (A)		DW18L W18L	717	425	51			
Bar	0.4	0.6	0.8	1	1.2	1.4	1.6	1.7	1.8	1.9	2	2.2	2.4	2.6	2.8
Psi	6	9	12	15	17	20	23	25	26	28	29	32	35	38	41
10 km/h	2250	2605	2960	3315	3660	4005	4350	4455	4565	4670	4775	4990	5205	5415	5630
30 km/h	1690	2010	2335	2655	2975	3300	3620	3705	3795	3880	3965	4140	4310		
40 km/h		1915	2250	2580	2870	3160	3450	3530	3615	3695	3780	3940	4105		
40 km/h Dual	1415	1700	1985	2270	2525	2780	3035	3110	3180	3255	3325	3470	3615		
50 km/h		1840	2155	2465	2780	3045	3305	3385	3465	3545	3625	3780	3940		
65 km/h			2360	2625	2885	3150	3225	3300	3375	3450	3600	3750			

* Se référer aux remarques en fin des tableaux de cette gamme

MICHELIN MACHXBIB

Caractéristiques & Pression en bar / psi – Charges par pneu en kg*

Ø pouces	Description	CAI	e mm	D mm	R' mm	Cdr. mm	Jante(s) recommandée(s)	Jante(s) tolérée(s)	Chambre à air (Code)	Volume interne 75% (litres)	Profond. de sculpture (mm)				
28	600/70R28 157D/154E TL NEW	211033	629	1571	703	4652	DW20B (A)	DW18L DW21B(A)	717	448	54				
Bar	0.4	0.6	0.8	1	1.2	1.4	1.6	1.7	1.8	1.9	2	2.2	2.4	2.6	2.8
Psi	6	9	12	15	17	20	23	25	26	28	29	32	35	38	41
10 km/h	2475	2800	3125	3450	3855	4260	4665	4870	5070	5275	5475	5655	5835	6010	6190
30 km/h	1900	2265	2630	2995	3355	3720	4085	4170	4250	4335	4415	4580	4745		
40 km/h		2135	2485	2835	3185	3535	3885	3965	4045	4120	4200	4360	4515		
40 km/h Dual	1590	1895	2200	2505	2810	3115	3420	3490	3560	3630	3700	3835	3975		
50 km/h		2050	2385	2720	3060	3395	3730	3805	3880	3955	4030	4180	4330		
65 km/h			2300	2615	2925	3240	3550	3620	3695	3765	3840	3980	4125		
70 km/h			2095	2380	2665	2945	3230	3295	3360	3425	3490	3620	3750		

Ø pouces	Description	CAI	e mm	D mm	R' mm	Cdr. mm	Jante(s) recommandée(s)	Jante(s) tolérée(s)	Chambre à air (Code)	Volume interne 75% (litres)	Profond. de sculpture (mm)		
28	600/70R28 157A8/157B TL	395016	623	1586	701	4694	DW20B (A)	DW18L	717	495	53		
Bar	0.4	0.6	0.8	1	1.2	1.4	1.6	1.7	1.8	1.9	2	2.2	2.4
Psi	6	9	12	15	17	20	23	25	26	28	29	32	35
10 km/h				3470	3855	4245	4630	4825	5020	5215	5410	5800	6190
30 km/h	1770	2160	2560	2955	3355	3750	4150	4185	4215	4250	4280	4345	4410
40 km/h				2850	3200	3550	3900	3930	3960	3985	4015	4075	4130
40 km/h Dual	1435	1795	2150	2510	2815	3125	3430	3455	3480	3505	3535	3585	3635
50 km/h					3200	3550	3900	3930	3960	3985	4015	4075	4130

Ø pouces	Description	CAI	e mm	D mm	R' mm	Cdr. mm	Jante(s) recommandée(s)	Jante(s) tolérée(s)	Chambre à air (Code)	Volume interne 75% (litres)	Profond. de sculpture (mm)
30	710/55R30 153D TL	992342	678	1518	668	4489	DW23B (A)			506	50
Bar	0.4	0.6	0.8	1	1.2	1.4	1.6	1.7	1.8	1.9	
Psi	6	9	12	15	17	20	23	25	26	28	
10 km/h	2475	2960	3370	3775	4185	4590	5000	5160	5320	5480	
30 km/h	1900	2270	2655	3040	3430	3815	4200				
40 km/h		2165	2530	2900	3265	3635	4000				
40 km/h Dual	1590	1905	2225	2550	2870	3195	3515				
50 km/h		2075	2425	2775	3130	3480	3830				
65 km/h			2300	2650	2985	3315	3650				

* Se référer aux remarques en fin des tableaux de cette gamme

MICHELIN MACHXBIB

Caractéristiques & Pression en bar / psi – Charges par pneu en kg*

Ø pouces	Description	CAI	e mm	D mm	R' mm	Cdr mm	Jante(s) recommandée(s)	Jante(s) tolérée(s)	Chambre à air (Code)	Volume interne 75% (litres)	Profond. de sculpture (mm)				
30	600/70R30 158D TL NEW	566557	638	1604	717	4760	DW20B (A)	DW18L DW21B (A)	737	468	56				
Bar	0.4	0.6	0.8	1	1.2	1.4	1.6	1.7	1.8	1.9	2	2.2	2.4	2.6	2.8
Psi	6	9	12	15	17	20	23	25	26	28	29	32	35	38	41
10 km/h	2475	2830	3185	3540	3955	4375	4790	5000	5210	5415	5625	5815	6000	6190	6375
30 km/h	1900	2285	2665	3050	3435	3815	4200	4285	4375	4460	4545	4720	4890		
40 km/h		2190	2550	2910	3275	3635	3995	4080	4160	4245	4325	4490	4655		
40 km/h Dual	1590	1910	2230	2555	2875	3195	3515	3590	3660	3735	3805	3950	4095		
50 km/h		2100	2445	2795	3140	3490	3835	3915	3995	4070	4150	4310	4465		
65 km/h			2360	2685	3005	3325	3650	3725	3800	3875	3950	4100	4250		

Ø pouces	Description	CAI	e mm	D mm	R' mm	Cdr mm	Jante(s) recommandée(s)	Jante(s) tolérée(s)	Chambre à air (Code)	Volume interne 75% (litres)	Profond. de sculpture (mm)
30	600/70R30 152D TL	334318	613	1605	706	4745	DW20B (A)	DW18L	737	456	56
Bar	0.4	0.6	0.8	1	1.2	1.4	1.6	1.7	1.8	1.9	
Psi	6	9	12	15	17	20	23	25	26	28	
10 km/h	2500	3000	3250	3750	4175	4600	5025	5125	5230	5330	
30 km/h	1915	2300	2680	3060	3440	3820	4200				
40 km/h		2190	2550	2910	3275	3635	3995				
40 km/h Dual	1605	1930	2250	2565	2885	3200	3520				
50 km/h		2100	2445	2790	3140	3485	3830				
65 km/h			2335	2665	2960	3255	3550				

Ø pouces	Description	CAI	e mm	D mm	R' mm	Cdr mm	Jante(s) recommandée(s)	Jante(s) tolérée(s)	Chambre à air (Code)	Volume interne 75% (litres)	Profond. de sculpture (mm)
32	680/75R32 164A8/161B TL XM28	123582	675	1865	819	5512	DW21B (A)	DW20B (A)	831	743	58
Bar	0.4	0.6	0.8	1	1.2	1.4	1.6	1.7	1.8	1.9	
Psi	6	9	12	15	17	20	23	25	26	28	
10 km/h	3230	4430	4900	5375	5845	6320	6790	7030	7265	7500	
30 km/h	2510	3480	3855	4230	4600	4975	5350				
40 km/h		3250	3600	3950	4300	4650	5000				
40 km/h Dual	1970	2860	3170	3475	3785	4090	4400				
50 km/h		3050	3365	3680	4000	4315	4630				

* Se référer aux remarques en fin des tableaux de cette gamme

MICHELIN MACHXBIB

Caractéristiques & Pression en bar / psi – Charges par pneu en kg*

Ø pouces	Description	CAI	e mm	D mm	R' mm	Cdr mm	Jante(s) recommandée(s)	Jante(s) tolérée(s)	Chambre à air (Code)	Volume interne 75% (litres)	Profond. de sculpture (mm)					
34	650/60R34 159D/155E TL	549996	659	1664	752	4950	DW21B (A)	DW20B (A) DW23B (A)	823	500	58					
Bar	0.4	0.6	0.8	1	1.2	1.4	1.6	1.7	1.8	1.9	2	2.2	2.4	2.6	2.8	
Psi	6	9	12	15	17	20	23	25	26	28	29	32	35	38	41	
10 km/h	2475	2800	3125	3450	3885	4320	4755	4975	5190	5410	5625	5860	6095	6330	6565	
30 km/h	1900	2285	2665	3050	3435	3815	4200	4305	4410	4510	4615	4825	5030			
40 km/h		2190	2550	2910	3275	3635	3995	4095	4195	4295	4395	4590	4790			
40 km/h Dual	1590	1910	2230	2555	2875	3195	3515	3605	3690	3780	3865	4040	4215			
50 km/h		2100	2445	2795	3140	3490	3835	3930	4025	4120	4215	4405	4595			
65 km/h			2300	2640	2975	3310	3650	3740	3830	3920	4015	4195	4375			
70 km/h				2095	2400	2710	3015	3320	3390	3460	3530	3600	3735	3875		

Ø pouces	Description	CAI	e mm	D mm	R' mm	Cdr mm	Jante(s) recommandée(s)	Jante(s) tolérée(s)	Chambre à air (Code)	Volume interne 75% (litres)	Profond. de sculpture (mm)					
34	650/65R34 161D/157E TL	817386	666	1726	779	5133	DW21B (A)	DW20B (A) DW23B (A)	823	555	58					
Bar	0.4	0.6	0.8	1	1.2	1.4	1.6	1.7	1.8	1.9	2	2.2	2.4	2.6	2.8	
Psi	6	9	12	15	17	20	23	25	26	28	29	32	35	38	41	
10 km/h	2700	3090	3475	3865	4290	4720	5145	5360	5575	5785	6000	6235	6470	6705	6940	
30 km/h	2070	2470	2865	3265	3660	4055	4455	4565	4670	4780	4890	5105	5320			
40 km/h		2385	2755	3130	3500	3875	4245	4350	4450	4555	4655	4860	5065			
40 km/h Dual	1735	2070	2400	2735	3070	3400	3735	3825	3915	4005	4095	4275	4455			
50 km/h		2290	2645	3000	3360	3715	4070	4170	4265	4365	4465	4660	4855			
65 km/h			2575	2900	3225	3550	3875	3970	4065	4155	4250	4440	4625			
70 km/h				2345	2640	2935	3230	3525	3600	3675	3750	3825	3975	4125		

Ø pouces	Description	CAI	e mm	D mm	R' mm	Cdr mm	Jante(s) recommandée(s)	Jante(s) tolérée(s)	Chambre à air (Code)	Volume interne 75% (litres)	Profond. de sculpture (mm)				
38	650/75R38 169A8/169B TL	219467	700	1955		5800	DW23B (A)	MW23B (A)	804	731	61				
Bar	0.4	0.6	0.8	1	1.2	1.4	1.6	1.7	1.8	1.9	2	2.2	2.4	2.6	2.8
Psi	6	9	12	15	17	20	23	25	26	28	29	32	35	38	41
10 km/h	3360	4150	4940	5730	6050	6370	6690	6860	7025	7195	7360	7695	8030	8365	8700
30 km/h	2410	3075	3745	4410	4680	4950	5220	5345	5470	5590	5715	5965	6210		
40 km/h		2725	3435	4140	4385	4630	4875	4990	5105	5220	5340	5570	5800		
40 km/h Dual	1965	2525	3085	3645	3860	4075	4290	4390	4495	4595	4700	4900	5105		
50 km/h		2725	3435	4140	4385	4630	4875	4990	5105	5220	5340	5570	5800		

* Se référer aux remarques en fin des tableaux de cette gamme

MICHELIN MACHXBIB

Caractéristiques & Pression en bar / psi – Charges par pneu en kg*

Ø pouces	Description	CAI	e mm	D mm	R' mm	Cdc mm	Jante(s) recommandée(s)		Jante(s) tolérée(s)	Chambre à air (Code)	Volume interne 75% (litres)	Profond. de sculpture (mm)			
38	710/70R38 171D TL	708197	713	1973	871	5804	DW23B (A)		MW23B (A) DW25B (A) MW25B (A)	804	811	62			
Bar	0.4	0.6	0.8	1	1.2	1.4	1.6	1.7	1.8	1.9	2	2.2	2.4	2.6	2.8
Psi	6	9	12	15	17	20	23	25	26	28	29	32	35	38	41
10 km/h	3640	4250	4860	5470	6010	6550	7095	7365	7635	7905	8175	8440	8700	8965	9225
30 km/h	2790	3340	3890	4445	4995	5545	6095	6215	6340	6460	6585	6825	7070		
40 km/h		3190	3725	4255	4770	5290	5805	5920	6040	6155	6270	6505	6735		
40 km/h Dual	2340	2800	3260	3725	4185	4645	5105	5210	5310	5415	5515	5720	5925		
50 km/h		3060	3570	4080	4575	5070	5565	5675	5790	5900	6010	6235	6455		
65 km/h			3350	3840	4325	4815	5300	5405	5515	5620	5725	5940	6150		

Ø pouces	Description	CAI	e mm	D mm	R' mm	Cdc mm	Jante(s) recommandée(s)		Jante(s) tolérée(s)	Chambre à air (Code)	Volume interne 75% (litres)	Profond. de sculpture (mm)			
38	650/85R38 173A8/173B TL	118628	686	2063	924	6092	DW23B (A)		DW20B (A) MW23B (A)	804	860	64			
Bar	0.4	0.6	0.8	1	1.2	1.4	1.6	1.7	1.8	1.9	2	2.2	2.4	2.6	2.8
Psi	6	9	12	15	17	20	23	25	26	28	29	32	35	38	41
10 km/h	3750	4640	5530	6420	6780	7140	7500	7690	7875	8065	8250	8625	9000	9375	9750
10 km/h Cyc Dual				6400	6760	7120	7480	7665	7855	8040	8230	8605	8975	9350	9725
30 km/h	2700	3445	4195	4940	5245	5545	5850	5990	6125	6265	6400	6680	6955		
40 km/h		3000	3820	4640	4910	5180	5450	5580	5715	5845	5975	6240	6500		
40 km/h Dual	2200	2830	3455	4085	4320	4560	4795	4910	5025	5140	5260	5490	5720		
50 km/h		3000	3820	4640	4910	5180	5450	5580	5715	5845	5975	6240	6500		

Ø pouces	Description	CAI	e mm	D mm	R' mm	Cdc mm	Jante(s) recommandée(s)		Jante(s) tolérée(s)	Chambre à air (Code)	Volume interne 75% (litres)	Profond. de sculpture (mm)
38	800/70R38 173D TL	887730	809	2066	899	6093	DW25B (A)		MW25B (A) DW27B (A)		1071	61
Bar	0.4	0.6	0.8	1	1.2	1.4	1.6	1.7	1.8	1.9	2	
Psi	6	9	12	15	17	20	23	25	26	28	29	
10 km/h	4400	5115	5825	6540	7255	7965	8680	9035	9395	9750		
10 km/h Cyc Dual				5260	6155	7045	7940	8390	8835	9280	9725	
30 km/h	3375	4060	4740	5425	6110	6790	7475					
40 km/h		3860	4510	5165	5815	6470	7120					
40 km/h Dual	2825	3400	3970	4545	5115	5690	6260					
50 km/h		3700	4325	4950	5575	6200	6825					
65 km/h			4115	4710	5305	5905	6500					

* Se référer aux remarques en fin des tableaux de cette gamme

MICHELIN MACHXBIB

Caractéristiques & Pression en bar / psi – Charges par pneu en kg*

Ø pouces	Description	CAI	e mm	D mm	R' mm	Cdr mm	Jante(s) recommandée(s)	Jante(s) tolérée(s)	Chambre à air (Code)	Volume interne 75% (litres)	Profond. de sculpture (mm)
42	900/50R42 168D TL	832458	853	1970	870	5826	DW27B (A)	DW28B (A) DW30B (A)		923	55
Bar	0.4	0.6	0.8	1	1.2	1.4	1.6	1.7	1.8	1.9	
Psi	6	9	12	15	17	20	23	25	26	28	
10 km/h	3825	4575	5195	5810	6430	7045	7665	7910	8155	8400	
30 km/h	2930	3510	4095	4680	5270	5855	6440				
40 km/h		3340	3900	4455	5015	5570	6130				
40 km/h Dual	2455	2940	3430	3925	4415	4910	5400				
50 km/h		3200	3735	4270	4810	5345	5880				
65 km/h		3550	4090	4595	5095	5600					

Ø pouces	Description	CAI	e mm	D mm	R' mm	Cdr mm	Jante(s) recommandée(s)	Jante(s) tolérée(s)	Chambre à air (Code)	Volume interne 75% (litres)	Profond. de sculpture (mm)				
42	710/70R42 173D TL	790388	721	2088	932	6195	DW23B (A)	MW23B (A) DW25B (A) MW25B (A)	802	872	64				
Bar	0.4	0.6	0.8	1	1.2	1.4	1.6	1.7	1.8	1.9	2	2.2	2.4	2.6	2.8
Psi	6	9	12	15	17	20	23	25	26	28	29	32	35	38	41
10 km/h	3750	4375	5000	5625	6210	6795	7380	7675	7965	8260	8550	8850	9150	9450	9750
10 km/h Cyc Dual				4390	5190	5985	6785	7185	7580	7980	8380	8715	9050	9390	9725
30 km/h	2875	3470	4065	4660	5250	5845	6440	6570	6700	6830	6960	7215	7475		
40 km/h		3285	3835	4380	4965	5545	6130	6255	6380	6500	6625	6875	7120		
40 km/h Dual	2410	2910	3405	3905	4405	4900	5400	5510	5615	5725	5835	6050	6265		
50 km/h		3150	3675	4200	4760	5320	5880	6000	6115	6235	6355	6590	6825		
65 km/h				4000	4535	5065	5600	5715	5825	5940	6050	6275	6500		

Ø pouces	Description	CAI	e mm	D mm	R' mm	Cdr mm	Jante(s) recommandée(s)	Jante(s) tolérée(s)	Chambre à air (Code)	Volume interne 75% (litres)	Profond. de sculpture (mm)				
42	710/75R42 175D/171E TL	015540	693	2158	968	6408	DW23B (A)	DW25B (A)	802	867	61				
Bar	0.4	0.6	0.8	1	1.2	1.4	1.6	1.7	1.8	1.9	2	2.2	2.4	2.6	2.8
Psi	6	9	12	15	17	20	23	25	26	28	29	32	35	38	41
10 km/h	3975	4775	5575	6375	7050	7725	8400	8740	9075	9415	9750	10125	10500	10875	11250
30 km/h	3050	3690	4335	4975	5615	6260	6900	7030	7160	7290	7420	7675	7935		
40 km/h		3560	4160	4765	5365	5970	6570	6695	6815	6940	7065	7310	7555		
40 km/h Dual	2555	3095	3630	4170	4705	5245	5780	5890	6000	6105	6215	6435	6650		
50 km/h		3415	3990	4570	5145	5725	6300	6420	6535	6655	6775	7010	7245		
65 km/h		3750	4315	4875	5440	6000	6115	6225	6340	6450	6675	6900			
70 km/h			3415	3925	4440	4950	5460	5545	5635	5720	5805	5980	6150		

* Se référer aux remarques en fin des tableaux de cette gamme

MICHELIN MACHXBIB

Caractéristiques & Pression en bar / psi – Charges par pneu en kg*

Ø pouces	Description	CAI	e mm	D mm	R' mm	Cdc mm	Jante(s) recommandée(s)	Jante(s) tolérée(s)	Chambre à air (Code)	Volume interne 75% (litres)	Profond. de sculpture (mm)
46	620/70R46 162D TL NEW	131721	647	2038	907	6041	DW20B (A)	DW18L MW20B (A) TW20B	834	677	58
Bar	0.4	0.6	0.8	1	1.2	1.4	1.6	1.7	1.8	1.9	
Psi	6	9	12	15	17	20	23	25	26	28	
10 km/h	3180	3705	4235	4760	5285	5815	6340	6600	6865	7125	
30 km/h	2440	2945	3450	3955	4460	4960	5465				
40 km/h		2820	3300	3775	4250	4725	5200				
40 km/h Dual	2045	2465	2890	3310	3730	4155	4575				
50 km/h		2705	3165	3620	4075	4535	4990				
65 km/h			3000	3440	3875	4315	4750				

Ø pouces	Description	CAI	e mm	D mm	R' mm	Cdc mm	Jante(s) recommandée(s)	Jante(s) tolérée(s)	Chambre à air (Code)	Volume interne 75% (litres)	Profond. de sculpture (mm)
46	620/70R46 162A8/162B TL XM28	122723	621	2061	926	6122	DW20B (A)		834	698	57
Bar	0.4	0.6	0.8	1	1.2	1.4	1.6	1.7	1.8	1.9	
Psi	6	9	12	15	17	20	23	25	26	28	
10 km/h	3060	4200	4650	5100	5550	6005	6455	6680	6905	7130	
30 km/h	2390	3300	3655	4010	4370	4725	5080				
40 km/h		3090	3420	3755	4085	4420	4750				
40 km/h Dual	1865	2720	3010	3305	3595	3890	4180				
50 km/h		3090	3420	3755	4085	4420	4750				

***REMARQUES**

La pression de gonflage se détermine toujours en fonction de la charge par pneu, de la vitesse et du travail à réaliser.
 Nos préconisations ci-dessus sont fournies sous réserve de modifications postérieures à la date de diffusion de ces tableaux (mars 2021).
 Les données techniques sont susceptibles d'évoluer sans information préalable.

- Pour un usage labour et d'autres usages champ sous couple élevé, utiliser la ligne 30 km/h.
- Lors d'un usage en monte simple :
 - Pour usage en dévers >20% : ajouter 0,4 bar.
 - Pour usage routier intensif >50% : ajouter 0,4 bar.



MICHELIN XEOBIB

AU QUOTIDIEN
SUR TOUTES SURFACES
À MOINS D'1 BAR



POUR TRACTEURS jusqu'à 220 CV

(Pour de fortes charges / des couples élevés,
utilisez MICHELIN MACHXBIB / AXIOBIB / AXIOBIB 2)



VF Très basse pression



RENDEMENTS

- + 4% / An⁽¹⁾
- **DURÉE DE VIE** excellente



ÉCONOMIES DE CARBURANT

- jusqu'à 15% en exploitation dans les champs⁽²⁾



CONFORT

- Absorbe les chocs et les irrégularités du sol

(1) Harper Adams University 2014/2016

(2) Moyenne observée en comparaison avec une dimension standard lors de tests sur surfaces agricoles

DIMENSIONS

VF 480/60R28 134D TL

VF 520/60R28 138D TL

VF 600/60R28 146D TL

VF 600/60R30 147D TL

VF 600/60R34 149D TL

VF 600/60R38 151D TL

VF 650/60R38 155D TL

VF 710/60R38 160D TL

VF 650/60R42 157D TL

VF 710/60R42 161D TL

MICHELIN XEOBIB

Caractéristiques & Pression en bar / psi – Charges par pneu en kg*

Ø pouces	Description	CAI	e mm	D mm	R' mm	Cdr mm	Jante(s) recommandée(s)	Jante(s) tolérée(s)	Chambre à air (Code)	Volume interne 75% (litres)	Profond. de sculpture (mm)
28	VF 480/60R28 134D TL	312875	488	1298	567	3831	DW16L	W16L	821	218	45
Bar	0.4	0.5	0.6	0.7	0.8	0.9	1	1.8			
Psi	6	7	9	10	12	13	15	26			
10 km/h	1450	1605	1760	1900	2035	2185	2330				
10 km/h Charg Fr								3000			
30 km/h	1345	1490	1630	1760	1885	2025	2160				
65 km/h	1320	1460	1600	1725	1850	1985	2120				
65 km/h Dual	1160	1285	1410	1520	1630	1750	1865				

Ø pouces	Description	CAI	e mm	D mm	R' mm	Cdr mm	Jante(s) recommandée(s)	Jante(s) tolérée(s)	Chambre à air (Code)	Volume interne 75% (litres)	Profond. de sculpture (mm)
28	VF 520/60R28 138D TL	510495	534	1338	579	3942	DW18L	W18L	822	260	46
Bar	0.4	0.5	0.6	0.7	0.8	0.9	1	1.8			
Psi	6	7	9	10	12	13	15	26			
10 km/h	1650	1815	1980	2125	2265	2430	2595				
10 km/h Charg Fr								3350			
30 km/h	1530	1685	1835	1970	2100	2255	2405				
65 km/h	1500	1650	1800	1930	2060	2210	2360				
65 km/h Dual	1320	1455	1585	1700	1815	1945	2075				

Ø pouces	Description	CAI	e mm	D mm	R' mm	Cdr mm	Jante(s) recommandée(s)	Jante(s) tolérée(s)	Chambre à air (Code)	Volume interne 75% (litres)	Profond. de sculpture (mm)
28	VF 600/60R28 146D TL	665184	597	1429	610	4198	DW20B (A)		822	365	48
Bar	0.4	0.5	0.6	0.7	0.8	0.9	1	1.8			
Psi	6	7	9	10	12	13	15	26			
10 km/h	2035	2250	2465	2690	2915	3110	3300				
10 km/h Charg Fr								4250			
30 km/h	1885	2085	2285	2495	2705	2885	3060				
65 km/h	1850	2045	2240	2445	2650	2825	3000				
65 km/h Dual	1630	1800	1970	2150	2330	2485	2640				

* Se référer aux remarques en fin des tableaux de cette gamme

MICHELIN XEOBIB

Caractéristiques & Pression en bar / psi – Charges par pneu en kg*

Ø pouces	Description	CAI	e mm	D mm	R' mm	Cdr mm	Jante(s) recommandée(s)	Jante(s) tolérée(s)	Chambre à air (Code)	Volume interne 75% (litres)	Profond. de sculpture (mm)
30	VF 600/60R30 147D TL	065253	603	1493	633	4379	DW20B (A)		757	383	50
Bar	0.4	0.5	0.6	0.7	0.8	0.9	1	1.8			
Psi	6	7	9	10	12	13	15	26			
10 km/h	2145	2340	2530	2765	3000	3195	3385				
10 km/h Charg Fr								4375			
30 km/h	1990	2170	2345	2565	2780	2960	3135				
65 km/h	1950	2125	2300	2515	2725	2900	3075				
65 km/h Dual	1715	1870	2025	2215	2400	2555	2705				

Ø pouces	Description	CAI	e mm	D mm	R' mm	Cdr mm	Jante(s) recommandée(s)	Jante(s) tolérée(s)	Chambre à air (Code)	Volume interne 75% (litres)	Profond. de sculpture (mm)
34	VF 600/60R34 149D TL	664777	595	1595	690	4699	DW20B (A)		823	416	48
Bar	0.4	0.5	0.6	0.7	0.8	0.9	1	1.8			
Psi	6	7	9	10	12	13	15	26			
10 km/h	2265	2470	2675	2935	3190	3385	3575				
10 km/h Charg Fr								4550			
30 km/h	2100	2290	2480	2720	2960	3140	3315				
65 km/h	2060	2245	2430	2665	2900	3075	3250				
65 km/h Dual	1815	1980	2140	2345	2550	2705	2860				

Ø pouces	Description	CAI	e mm	D mm	R' mm	Cdr mm	Jante(s) recommandée(s)	Jante(s) tolérée(s)	Chambre à air (Code)	Volume interne 75% (litres)	Profond. de sculpture (mm)
38	VF 600/60R38 151D TL	349257	549	1698	749	5023	DW20B (A)	MW20B (A)	824	452	52
Bar	0.4	0.5	0.6	0.7	0.8	0.9	1				
Psi	6	7	9	10	12	13	15				
10 km/h	2400	2620	2835	3070	3300	3550	3795				
30 km/h	2225	2425	2625	2845	3060	3290	3520				
65 km/h	2180	2380	2575	2790	3000	3225	3450				
65 km/h Dual	1920	2095	2265	2455	2640	2840	3035				

Ø pouces	Description	CAI	e mm	D mm	R' mm	Cdr mm	Jante(s) recommandée(s)	Jante(s) tolérée(s)	Chambre à air (Code)	Volume interne 75% (litres)	Profond. de sculpture (mm)
38	VF 650/60R38 155D TL	454365	677	1735	749	5108	DW23B (A)	MW23B (A)	825	539	52
Bar	0.4	0.5	0.6	0.7	0.8	0.9	1				
Psi	6	7	9	10	12	13	15				
10 km/h	2675	2935	3190	3495	3795	4030	4265				
30 km/h	2480	2720	2960	3240	3520	3740	3955				
65 km/h	2430	2665	2900	3175	3450	3665	3875				
65 km/h Dual	2140	2345	2550	2795	3035	3225	3410				

* Se référer aux remarques en fin des tableaux de cette gamme

MICHELIN XEOBIB

Caractéristiques & Pression en bar / psi – Charges par pneu en kg*

Ø pouces	Description	CAI	e mm	D mm	R' mm	Cdr. mm	Jante(s) recommandée(s)	Jante(s) tolérée(s)	Chambre à air (Code)	Volume interne 75% (litres)	Profond. de sculpture (mm)
38	VF 710/60R38 160D TL	324138	712	1814	794	5356	DW25B (A)	MW25B (A)	825	665	54
Bar	0.4	0.5	0.6	0.7	0.8	0.9	1				
Psi	6	7	9	10	12	13	15				
10 km/h	3080	3385	3685	3975	4265	4610	4950				
30 km/h	2855	3135	3415	3685	3955	4275	4590				
65 km/h	2800	3075	3350	3615	3875	4190	4500				
65 km/h Dual	2465	2710	2950	3180	3410	3685	3960				

Ø pouces	Description	CAI	e mm	D mm	R' mm	Cdr. mm	Jante(s) recommandée(s)	Jante(s) tolérée(s)	Chambre à air (Code)	Volume interne 75% (litres)	Profond. de sculpture (mm)
42	VF 650/60R42 157D TL	220583	660	1840	810	5441	DW23B (A)	DW20B (A) (NRO)	802	645	58
Bar	0.4	0.5	0.6	0.7	0.8	0.9	1				
Psi	6	7	9	10	12	13	15				
10 km/h	2835	3110	3385	3645	3905	4225	4540				
30 km/h	2625	2880	3135	3380	3620	3915	4210				
65 km/h	2575	2825	3075	3315	3550	3840	4125				
65 km/h Dual	2265	2485	2705	2915	3125	3380	3630				

Ø pouces	Description	CAI	e mm	D mm	R' mm	Cdr. mm	Jante(s) recommandée(s)	Jante(s) tolérée(s)	Chambre à air (Code)	Volume interne 75% (litres)	Profond. de sculpture (mm)
42	VF 710/60R42 161D TL	144294	716	1920	843	5675	DW25B (A)	MW25B (A)	802	713	57
Bar	0.4	0.5	0.6	0.7	0.8	0.9	1				
Psi	6	7	9	10	12	13	15				
10 km/h	3190	3495	3795	4170	4540	4815	5090				
30 km/h	2960	3240	3520	3865	4210	4465	4720				
65 km/h	2900	3175	3450	3790	4125	4375	4625				
65 km/h Dual	2550	2795	3035	3335	3630	3850	4070				

***REMARQUES**

La pression de gonflage se détermine toujours en fonction de la charge par pneu, de la vitesse et du travail à réaliser.
 Nos préconisations ci-dessus sont fournies sous réserve de modifications postérieures à la date de diffusion de ces tableaux (mars 2021).
 Les données techniques sont susceptibles d'évoluer sans information préalable.

- Lors d'un usage en monte simple :
 - Pour usage en dévers >20% : ajouter 0,4 bar.
 - Pour usage routier intensif >50% : ajouter 0,4 bar.
- 10 km/h Charg Fr : utilisation chargeur frontal, vitesse maxi 10 km/h.



MICHELIN MULTIBIB

**DURÉE D'EXPLOITATION
PLUS LONGUE POUR UN
KILOMÉTRAGE AUGMENTÉ**



POUR TRACTEURS jusqu'à 220 CV

(Pour de fortes charges / des couples élevés,
utilisez MICHELIN MACHXBIB / AXIOBIB / AXIOBIB 2)



POLYVALENCE

- Haute performance sur les surfaces agricoles et sur route



PRODUCTIVITÉ

- Forte TRACTION pour économiser du temps et du carburant
- Protection des sols
- Capable de vitesses jusqu'à 65 km/h⁽¹⁾



LONGÉVITÉ

- Meilleure bande de roulement comparée aux 4 principaux concurrents⁽²⁾



CONFORT

- Excellente maniabilité sur route
- Confort de roulement amélioré pour le conducteur



(1) Lorsque autorisé par les lois du pays

(2) Pour la dimension 650/65 R42 158D TL

DIMENSIONS

320/65R16 107D TL

320/65R18 109A8/106B TL

340/65R18 113A8/110B TL

420/65R20 125A8/125B TL

440/65R20 128D TL

420/65R24 126D TL

420/65R24 126A8/126B TL

440/65R24 128D TL

480/65R24 133D TL

540/65R24 140D TL

420/65R28 135D TL

440/65R28 131D TL

480/65R28 136D TL

540/65R28 142D TL

540/65R30 143D TL

540/65R34 145D TL

540/65R34 152D TL

600/65R34 151D TL

540/65R38 147D TL

600/65R38 153D TL

650/65R38 157D TL

650/65R42 158D TL

MICHELIN MULTIBIB

Caractéristiques & Pression en bar / psi – Charges par pneu en kg*

Ø pouces	Description	CAI	e mm	D mm	R' mm	Cdr mm	Jante(s) recommandée(s)	Jante(s) tolérée(s)	Chambre à air (Code)	Volume interne 75% (litres)	Profond. de sculpture (mm)
16	320/65R16 107D TL	494658	300	827	368	2452	W10L	W9		65	29
Bar	0.5	0.6	0.8	1	1.2	1.4	1.6	1.8			
Psi	7	9	12	15	17	20	23	26			
10 km/h	580	760	885	1015	1140	1270	1395				
30 km/h	570	620	720	820	1025						
40 km/h	580	680	775	975							
50 km/h	555	650	745	935							
65 km/h	535	625	710	890							

Ø pouces	Description	CAI	e mm	D mm	R' mm	Cdr mm	Jante(s) recommandée(s)	Jante(s) tolérée(s)	Chambre à air (Code)	Volume interne 75% (litres)	Profond. de sculpture (mm)
18	320/65R18 109A8/106B TL <i>XM108</i>	123898	309	875	389	2594	W9	W10	444	64	28
Bar	0.4	0.5	0.6	0.8	1	1.2	1.4	1.6	1.7	1.8	1.9
Psi	6	7	9	12	15	17	20	23	25	26	28
10 km/h	400	535	670	805	940	1075	1210	1345	1415	1480	1550
30 km/h	390	500	610	710	805	905	1000	1100			
40 km/h	460	570	665	755	850	940	1030				
50 km/h	430	520	605	690	780	865	950				

Ø pouces	Description	CAI	e mm	D mm	R' mm	Cdr mm	Jante(s) recommandée(s)	Jante(s) tolérée(s)	Chambre à air (Code)	Volume interne 75% (litres)	Profond. de sculpture (mm)
18	340/65R18 113A8/110B TL <i>XM108</i>	123888	336	911	400	2690	W9	W10 W11	444	80	28
Bar	0.4	0.5	0.6	0.8	1	1.2	1.4	1.6	1.7	1.8	1.9
Psi	6	7	9	12	15	17	20	23	25	26	28
10 km/h	450	600	750	900	1050	1200	1355	1505	1580	1655	1730
30 km/h	440	560	680	790	900	1010	1120	1230			
40 km/h	520	630	735	840	945	1050	1150				
50 km/h	480	580	675	770	870	965	1060				

Ø pouces	Description	CAI	e mm	D mm	R' mm	Cdr mm	Jante(s) recommandée(s)	Jante(s) tolérée(s)	Chambre à air (Code)	Volume interne 75% (litres)	Profond. de sculpture (mm)
20	420/65R20 125A8/125B TL <i>XM108</i>	122702	396	1064	461	3135	W11	W10 W12	664	140	36
Bar	0.4	0.5	0.6	0.8	1	1.2	1.4	1.6	1.7	1.8	
Psi	6	7	9	12	15	17	20	23	25	26	
10 km/h	970	1140	1310	1525	1735	1950	2160	2375	2480		
30 km/h	770	925	1080	1255	1425	1600	1770				
40 km/h	830	1010	1170	1330	1490	1650					
50 km/h	830	1010	1115	1225	1330	1435	1545	1595	1650		

* Se référer aux remarques en fin des tableaux de cette gamme

MICHELIN MULTIBIB

Caractéristiques & Pression en bar / psi – Charges par pneu en kg*

Ø pouces	Description	CAI	e mm	D mm	R' mm	Cdr. mm	Jante(s) recommandée(s)	Jante(s) tolérée(s)	Chambre à air (Code)	Volume interne 75% (litres)	Profond. de sculpture (mm)
20	440/65R20 128D TL	675464	445	1090	475	3260	W14L	W13 W15L	664	157	44
Bar	0.4	0.5	0.6	0.8	1	1.2	1.4	1.6	1.8	1.9	2
Psi	6	7	9	12	15	17	20	23	26	28	29
10 km/h	1200	1295	1390	1570	1750	1930	2125	2315	2510	2605	2700
30 km/h	920	1020	1120	1305	1485	1670	1870	2070			
40 km/h			1070	1245	1415	1590	1780	1970			
40 km/h Dual	770	855	940	1095	1245	1400	1570	1735			
50 km/h			1025	1165	1310	1450	1670	1890			
65 km/h			975	1135	1290	1450	1625	1800			

Ø pouces	Description	CAI	e mm	D mm	R' mm	Cdr. mm	Jante(s) recommandée(s)	Jante(s) tolérée(s)	Chambre à air (Code)	Volume interne 75% (litres)	Profond. de sculpture (mm)
24	420/65R24 126D TL	171560	392	1156	508	3416	W12	11 W11 DW12	700	159	38
Bar	0.4	0.5	0.6	0.8	1	1.2	1.4	1.6	1.8	1.9	2
Psi	6	7	9	12	15	17	20	23	26	28	29
10 km/h	1200	1315	1425	1575	1725	1875	2025	2175	2365	2455	2550
30 km/h	920	1010	1095	1290	1480	1670	1815	1955			
40 km/h			1040	1225	1410	1590	1725	1860			
50 km/h			1000	1175	1350	1525	1655	1785			
65 km/h			950	1120	1285	1450	1575	1700			

Ø pouces	Description	CAI	e mm	D mm	R' mm	Cdr. mm	Jante(s) recommandée(s)	Jante(s) tolérée(s)	Chambre à air (Code)	Volume interne 75% (litres)	Profond. de sculpture (mm)
24	420/65R24 126A8/126B TL <i>XM1108</i>	122712	395	1160	507	3425	W11	W10 W12	700	150	37
Bar	0.4	0.5	0.6	0.8	1	1.2	1.4	1.6	1.7	1.8	
Psi	6	7	9	12	15	17	20	23	25	26	
10 km/h	990	1170	1350	1570	1785	2005	2225	2440	2550		
30 km/h	790	950	1110	1290	1465	1645	1820				
40 km/h		850	1040	1205	1370	1535	1700				
50 km/h		850	1040	1150	1260	1370	1480	1590	1645	1700	

* Se référer aux remarques en fin des tableaux de cette gamme

MICHELIN MULTIBIB

Caractéristiques & Pression en bar / psi – Charges par pneu en kg*

Ø pouces	Description	CAI	e mm	D mm	R' mm	Cdr mm	Jante(s) recommandée(s)	Jante(s) tolérée(s)	Chambre à air (Code)	Volume interne 75% (litres)	Profond. de sculpture (mm)
24	440/65R24 128D TL	426389	439	1187	529	3519	DW14L	DW13 W13 W14L DW15L W15L	703	178	44
Bar	0.4	0.5	0.6	0.8	1	1.2	1.4	1.6	1.8	1.9	2
Psi	6	7	9	12	15	17	20	23	26	28	29
10 km/h	1285	1370	1450	1655	1855	2060	2225	2395	2560	2640	2725
30 km/h	980	1080	1180	1380	1580	1780	1925	2070			
40 km/h			1130	1320	1510	1700	1835	1970			
40 km/h Dual	820	910	995	1160	1330	1495	1615	1735			
50 km/h			1080	1265	1445	1630	1760	1890			
65 km/h			1030	1205	1375	1550	1675	1800			

Ø pouces	Description	CAI	e mm	D mm	R' mm	Cdr mm	Jante(s) recommandée(s)	Jante(s) tolérée(s)	Chambre à air (Code)	Volume interne 75% (litres)	Profond. de sculpture (mm)
24	480/65R24 133D TL	531721	483	1240	546	3667	DW15L	DW14L W14L W15L	710	218	46
Bar	0.4	0.5	0.6	0.8	1	1.2	1.4	1.6	1.8	1.9	2
Psi	6	7	9	12	15	17	20	23	26	28	29
10 km/h	1450	1575	1700	1920	2140	2360	2560	2755	2955	3050	3150
30 km/h	1120	1240	1360	1575	1795	2010	2190	2370			
40 km/h			1290	1500	1710	1920	2090	2260			
40 km/h Dual	940	1040	1135	1320	1505	1690	1840	1990			
50 km/h			1240	1440	1640	1840	2000	2160			
65 km/h			1180	1370	1560	1750	1905	2060			

Ø pouces	Description	CAI	e mm	D mm	R' mm	Cdr mm	Jante(s) recommandée(s)	Jante(s) tolérée(s)	Chambre à air (Code)	Volume interne 75% (litres)	Profond. de sculpture (mm)
24	540/65R24 140D TL	097057	532	1312	573	3873	DW16L	W16L DW18L W18L	710	287	48
Bar	0.4	0.5	0.6	0.8	1	1.2	1.4	1.6	1.8	1.9	2
Psi	6	7	9	12	15	17	20	23	26	28	29
10 km/h	1750	1875	2000	2265	2535	2800	3040	3275	3515	3630	3750
30 km/h	1360	1485	1610	1885	2165	2440	2660	2880			
40 km/h			1530	1795	2055	2320	2530	2740			
40 km/h Dual	1140	1245	1345	1575	1810	2040	2225	2410			
50 km/h			1470	1725	1975	2230	2430	2630			
65 km/h			1400	1640	1880	2120	2310	2500			

* Se référer aux remarques en fin des tableaux de cette gamme

MICHELIN MULTIBIB

Caractéristiques & Pression en bar / psi – Charges par pneu en kg*

Ø pouces	Description	CAI	e mm	D mm	R' mm	Cdr mm	Jante(s) recommandée(s)		Jante(s) tolérée(s)	Chambre à air (Code)	Volume interne 75% (litres)	Profond. de sculpture (mm)			
28	420/65R28 135D TL	778211	390	1238	558	3680	W11		W12	732	177	44			
Bar	0.4	0.5	0.6	0.8	1	1.2	1.4	1.6	1.8	1.9	2	2.2	2.4	2.7	2.8
Psi	6	7	9	12	15	17	20	23	26	28	29	32	35	39	41
10 km/h	1275	1410	1545	1710	1875	2040	2185	2325	2495	2580	2665	2830	3000	3205	3270
30 km/h	980	1085	1185	1355	1535	1715	1890	2070	2180	2235	2290	2395	2505		
40 km/h			1130	1290	1460	1630	1800	1970	2075	2125	2180	2280	2385		
40 km/h Dual	820	910	995	1160	1330	1495	1615	1735	1825	1870	1920	2010	2100	2230	2275
50 km/h			1030	1240	1405	1565	1725	1890	1990	2040	2090	2190	2290		
65 km/h			1030	1180	1335	1490	1645	1800	1895	1945	1990	2085	2180		

Ø pouces	Description	CAI	e mm	D mm	R' mm	Cdr mm	Jante(s) recommandée(s)		Jante(s) tolérée(s)	Chambre à air (Code)	Volume interne 75% (litres)	Profond. de sculpture (mm)
28	440/65R28 131D TL	386212	437	1291	579	3833	DW14L		W13 W14L DW15L W15L	821	198	43
Bar	0.4	0.5	0.6	0.8	1	1.2	1.4	1.6	1.8	1.9	2	
Psi	6	7	9	12	15	17	20	23	26	28	29	
10 km/h	1360	1480	1600	1795	1985	2180	2360	2540	2720	2810	2900	
30 km/h	1060	1155	1250	1465	1685	1900	2070	2240				
40 km/h			1190	1395	1605	1810	1975	2140				
40 km/h Dual	890	970	1045	1230	1410	1595	1740	1885				
50 km/h			1140	1335	1535	1730	1890	2050				
65 km/h			1090	1275	1465	1650	1800	1950				

Ø pouces	Description	CAI	e mm	D mm	R' mm	Cdr mm	Jante(s) recommandée(s)		Jante(s) tolérée(s)	Chambre à air (Code)	Volume interne 75% (litres)	Profond. de sculpture (mm)
28	480/65R28 136D TL	897574	476	1339	596	3970	DW15L		DW14L W14L W15L	822	242	45
Bar	0.4	0.5	0.6	0.8	1	1.2	1.4	1.6	1.8	1.9	2	
Psi	6	7	9	12	15	17	20	23	26	28	29	
10 km/h	1550	1675	1800	2035	2265	2500	2715	2925	3140	3245	3350	
30 km/h	1180	1310	1440	1690	1940	2190	2385	2580				
40 km/h			1370	1605	1845	2080	2265	2450				
40 km/h Dual	990	1100	1205	1415	1620	1830	1995	2155				
50 km/h			1310	1540	1770	2000	2175	2350				
65 km/h			1250	1465	1685	1900	2070	2240				

* Se référer aux remarques en fin des tableaux de cette gamme

MICHELIN MULTIBIB

Caractéristiques & Pression en bar / psi – Charges par pneu en kg*

Ø pouces	Description	CAI	e mm	D mm	R' mm	Cdr mm	Jante(s) recommandée(s)	Jante(s) tolérée(s)	Chambre à air (Code)	Volume interne 75% (litres)	Profond. de sculpture (mm)
28	540/65R28 142D TL	792274	529	1427	630	4223	DW16L	W16L DW18L W18L	822	318	48
Bar	0.4	0.5	0.6	0.8	1	1.2	1.4	1.6	1.8	1.9	2
Psi	6	7	9	12	15	17	20	23	26	28	29
10 km/h	1900	2040	2180	2455	2725	3000	3250	3500	3750	3875	4000
30 km/h	1440	1585	1730	2015	2295	2580	2815	3050			
40 km/h			1640	1910	2180	2450	2675	2900			
40 km/h Dual	1205	1325	1445	1680	1920	2155	2355	2550			
50 km/h			1580	1835	2095	2350	2565	2780			
65 km/h			1500	1745	1995	2240	2445	2650			

Ø pouces	Description	CAI	e mm	D mm	R' mm	Cdr mm	Jante(s) recommandée(s)	Jante(s) tolérée(s)	Chambre à air (Code)	Volume interne 75% (litres)	Profond. de sculpture (mm)
30	540/65R30 143D TL	223153	527	1472	648	4353	DW16L	W16L DW18L W18L	754	333	48
Bar	0.4	0.5	0.6	0.8	1	1.2	1.4	1.6	1.8	1.9	2
Psi	6	7	9	12	15	17	20	23	26	28	29
10 km/h	1950	2095	2240	2520	2795	3075	3340	3600	3865	3995	4125
30 km/h	1480	1630	1780	2070	2360	2650	2890	3130			
40 km/h			1700	1975	2245	2520	2750	2980			
40 km/h Dual	1240	1370	1495	1735	1980	2220	2420	2620			
50 km/h			1630	1895	2155	2420	2640	2860			
65 km/h			1550	1800	2050	2300	2515	2725			

Ø pouces	Description	CAI	e mm	D mm	R' mm	Cdr mm	Jante(s) recommandée(s)	Jante(s) tolérée(s)	Chambre à air (Code)	Volume interne 75% (litres)	Profond. de sculpture (mm)
34	540/65R34 145D TL	712064	530	1574	693	4655	DW16L	W16L DW18L W18L	704	364	48
Bar	0.4	0.5	0.6	0.8	1	1.2	1.4	1.6	1.8	1.9	2
Psi	6	7	9	12	15	17	20	23	26	28	29
10 km/h	2060	2210	2360	2655	2955	3250	3530	3815	4095	4235	4375
30 km/h	1560	1730	1900	2225	2555	2880	3110	3340			
40 km/h			1810	2120	2430	2740	2960	3180			
40 km/h Dual	1310	1455	1595	1865	2140	2410	2605	2800			
50 km/h			1730	2030	2330	2630	2840	3050			
65 km/h			1650	1935	2215	2500	2700	2900			

* Se référer aux remarques en fin des tableaux de cette gamme

MICHELIN MULTIBIB

Caractéristiques & Pression en bar / psi – Charges par pneu en kg*

Ø pouces	Description	CAI	e mm	D mm	R' mm	Cdr mm	Jante(s) recommandée(s)		Jante(s) tolérée(s)		Chambre à air (Code)	Volume interne 75% (litres)	Profond. de sculpture (mm)		
34	540/65R34 152D TL	214036	530	1590	709	4716	DW16L		W16L DW18L W18L		704	364	48		
Bar	0.4	0.5	0.6	0.8	1	1.2	1.4	1.6	1.8	1.9	2	2.2	2.4	2.7	2.8
Psi	6	7	9	12	15	17	20	23	26	28	29	32	35	39	41
10 km/h	2060	2210	2360	2655	2955	3250	3530	3815	4095	4235	4375	4625	4875	5215	5325
30 km/h	1560	1730	1900	2225	2555	2880	3110	3340	3525	3620	3710	3895	4080		
40 km/h			1810	2120	2430	2740	2960	3180	3360	3445	3535	3715	3890		
40 km/h Dual	1310	1455	1595	1865	2140	2410	2605	2800	2955	3035	3110	3265	3420		
50 km/h			1730	2030	2330	2630	2840	3050	3220	3305	3390	3560	3730		
65 km/h			1650	1935	2215	2500	2700	2900	3065	3145	3225	3390	3550		

Ø pouces	Description	CAI	e mm	D mm	R' mm	Cdr mm	Jante(s) recommandée(s)		Jante(s) tolérée(s)		Chambre à air (Code)	Volume interne 75% (litres)	Profond. de sculpture (mm)		
34	600/65R34 151D TL	557189	594	1654	732	4897	DW20B (A)		DW18L W18L		823	464	54		
Bar	0.4	0.5	0.6	0.8	1	1.2	1.4	1.6	1.8	1.9	2				
Psi	6	7	9	12	15	17	20	23	26	28	29				
10 km/h	2430	2615	2800	3160	3515	3875	4195	4515	4830	4990	5150				
30 km/h	1840	2040	2240	2605	2975	3340	3655	3970							
40 km/h			2140	2485	2835	3180	3480	3780							
40 km/h Dual	1540	1715	1885	2190	2495	2800	3065	3325							
50 km/h			2050	2385	2715	3050	3335	3620							
65 km/h			1950	2265	2585	2900	3175	3450							

Ø pouces	Description	CAI	e mm	D mm	R' mm	Cdr mm	Jante(s) recommandée(s)		Jante(s) tolérée(s)		Chambre à air (Code)	Volume interne 75% (litres)	Profond. de sculpture (mm)		
38	540/65R38 147D TL	114518	529	1675	745	4965	DW16L		W16L DW18L W18L		824	394	48		
Bar	0.4	0.5	0.6	0.8	1	1.2	1.4	1.6	1.8	1.9	2				
Psi	6	7	9	12	15	17	20	23	26	28	29				
10 km/h	2180	2340	2500	2815	3135	3450	3745	4040	4330	4480	4625				
30 km/h	1670	1840	2010	2325	2645	2960	3250	3540							
40 km/h			1920	2220	2520	2820	3095	3370							
40 km/h Dual	1400	1545	1690	1955	2215	2480	2725	2965							
50 km/h			1840	2125	2415	2700	2965	3230							
65 km/h			1750	2025	2300	2575	2825	3075							

* Se référer aux remarques en fin des tableaux de cette gamme

MICHELIN MULTIBIB

Caractéristiques & Pression en bar / psi – Charges par pneu en kg*

Ø pouces	Description	CAI	e mm	D mm	R' mm	Cdr mm	Jante(s) recommandée(s)	Jante(s) tolérée(s)	Chambre à air (Code)	Volume interne 75% (litres)	Profond. de sculpture (mm)
38	600/65R38 153D TL	228045	595	1768	779	5229	DW20B (A)	DW18L W18L	825	500	53
Bar	0.4	0.5	0.6	0.8	1	1.2	1.4	1.6	1.8	1.9	2
Psi	6	7	9	12	15	17	20	23	26	28	29
10 km/h	2575	2775	2970	3355	3740	4125	4455	4790	5120	5285	5450
30 km/h	1960	2165	2370	2760	3150	3540	3870	4200			
40 km/h			2260	2630	3000	3370	3685	4000			
40 km/h Dual	1645	1820	1990	2315	2640	2965	3245	3520			
50 km/h			2160	2515	2875	3230	3530	3830			
65 km/h			2060	2400	2735	3075	3365	3650			

Ø pouces	Description	CAI	e mm	D mm	R' mm	Cdr mm	Jante(s) recommandée(s)	Jante(s) tolérée(s)	Chambre à air (Code)	Volume interne 75% (litres)	Profond. de sculpture (mm)
38	650/65R38 157D TL	292904	646	1819	801	5380	DW20B (A)		825	602	56
Bar	0.4	0.5	0.6	0.8	1	1.2	1.4	1.6	1.8	1.9	2
Psi	6	7	9	12	15	17	20	23	26	28	29
10 km/h	2900	3125	3350	3775	4200	4625	5005	5390	5770	5960	6150
30 km/h	2190	2420	2650	3090	3530	3970	4355	4740			
40 km/h			2520	2940	3360	3780	4150	4520			
40 km/h Dual	1835	2030	2220	2590	2955	3325	3655	3980			
50 km/h			2420	2820	3220	3620	3975	4330			
65 km/h			2300	2685	3065	3450	3790	4125			

Ø pouces	Description	CAI	e mm	D mm	R' mm	Cdr mm	Jante(s) recommandée(s)	Jante(s) tolérée(s)	Chambre à air (Code)	Volume interne 75% (litres)	Profond. de sculpture (mm)
42	650/65R42 158D TL	167733	638	1931	858	5722	DW20B (A)		802	647	57
Bar	0.4	0.5	0.6	0.8	1	1.2	1.4	1.6	1.8	1.9	2
Psi	6	7	9	12	15	17	20	23	26	28	29
10 km/h	3000	3225	3450	3885	4315	4750	5155	5565	5970	6170	6375
30 km/h	2300	2545	2790	3260	3730	4200	4545	4890			
40 km/h			2660	3105	3555	4000	4325	4650			
40 km/h Dual	1930	2135	2340	2735	3125	3520	3805	4090			
50 km/h			2550	2975	3405	3830	4145	4460			
65 km/h			2430	2835	3245	3650	3950	4250			

*REMARQUES

La pression de gonflage se détermine toujours en fonction de la charge par pneu, de la vitesse et du travail à réaliser.

Nos préconisations ci-dessus sont fournies sous réserve de modifications postérieures à la date de diffusion de ces tableaux (mars 2021).

Les données techniques sont susceptibles d'évoluer sans information préalable.

- Pour un usage labour et d'autres usages champ sous couple élevé, utiliser la ligne 30 km/h.
- Lors d'un usage en monte simple :
 - Pour usage en dévers >20% : ajouter 0,4 bar.
 - Pour usage routier intensif >50% : ajouter 0,4 bar.



MICHELIN OMNIBIB

UNE POLYVALENCE ACCRUE
POUR OPTIMISER VOS COÛTS



POUR TRACTEURS jusqu'à 220 CV

(Pour de fortes charges / des couples élevés,
utilisez MICHELIN MACHXBIB / AXIOBIB / AXIOBIB 2)



POLYVALENCE

- Conçu spécialement pour résister aux sollicitations dues aux chargeurs frontaux
- Jusqu'à 14%⁽¹⁾ de **capacité de charge en plus**
- Excellente **stabilité & manœuvrabilité** pour évoluer dans les stabulations
- Super capacité de **traction**



LONGÉVITÉ

- Endurance de la carcasse éprouvée
- Résistance aux agressions

(1) Selon les dimensions de pneus et en comparaison avec la dimension équivalente MICHELIN AGRIBIB

DIMENSIONS

280/70R16 112D TL
280/70R20 116D TL
320/70R24 116D TL
360/70R24 122D TL
380/70R24 125D TL
420/70R24 130D TL

480/70R24 138D TL
380/70R28 127D TL
420/70R28 133D TL
480/70R28 140D TL
480/70R30 141D TL
480/70R34 143D TL

520/70R34 148D TL
480/70R38 145D TL
520/70R38 150D TL
580/70R38 155D TL
620/70R42 160D TL

MICHELIN OMNIBIB

Caractéristiques & Pression en bar / psi – Charges par pneu en kg*

Ø pouces	Description	CAI	e mm	D mm	R' mm	Cdr mm	Jante(s) recommandée(s)		Jante(s) tolérée(s)	Chambre à air (Code)	Volume interne 75% (litres)	Profond. de sculpture (mm)			
16	280/70R16 112D TL	747196	276	805	360	2400	W9		W10L W8L W8	184	45	29			
Bar	0.4	0.5	0.6	0.8	1	1.2	1.4	1.6	1.8	1.9	2	2.2	2.4	2.7	2.8
Psi	6	7	9	12	15	17	20	23	26	28	29	32	35	39	41
10 km/h	580	625	665	755	840	930	1015	1100	1190	1230	1275	1375	1480	1630	1680
30 km/h	445	490	535	625	715	800	890	980	1060	1095	1135	1215	1290		
40 km/h			505	590	675	760	845	930	1005	1040	1080	1150	1225		
40 km/h Dual	375	410	445	520	595	670	745	820	885	920	950	1015	1080		
50 km/h			485	565	650	730	815	895	965	1000	1035	1105	1175		
65 km/h			460	540	615	695	770	850	920	950	985	1055	1120		

Ø pouces	Description	CAI	e mm	D mm	R' mm	Cdr mm	Jante(s) recommandée(s)		Jante(s) tolérée(s)	Chambre à air (Code)	Volume interne 75% (litres)	Profond. de sculpture (mm)			
20	280/70R20 116D TL	263806	268	904	409	2690	W9		W8 W10	533	61	29			
Bar	0.4	0.5	0.6	0.8	1	1.2	1.4	1.6	1.8	1.9	2	2.2	2.4	2.7	2.8
Psi	6	7	9	12	15	17	20	23	26	28	29	32	35	39	41
10 km/h	640	690	740	835	935	1035	1130	1230	1325	1375	1425	1540	1650	1820	1875
30 km/h	490	540	590	690	795	895	995	1095	1180	1225	1270	1355	1440		
40 km/h			565	660	755	850	945	1040	1125	1165	1205	1290	1370		
50 km/h			540	630	725	815	910	1000	1080	1120	1160	1235	1315		
65 km/h			515	600	690	775	865	950	1025	1065	1100	1175	1250		

Ø pouces	Description	CAI	e mm	D mm	R' mm	Cdr mm	Jante(s) recommandée(s)		Jante(s) tolérée(s)	Chambre à air (Code)	Volume interne 75% (litres)	Profond. de sculpture (mm)
24	320/70R24 116D TL	415309	323	1101	497	3274	W10		W9 W11	692	94	40
Bar	0.4	0.5	0.6	0.8	1	1.2	1.4	1.6	1.8	1.9	2	
Psi	6	7	9	12	15	17	20	23	26	28	29	
10 km/h	870	935	995	1125	1250	1375	1500	1630	1755	1815	1880	
30 km/h	670	735	800	925	1055	1185	1310	1440				
40 km/h			760	880	1005	1125	1250	1370				
40 km/h Dual	560	615	670	775	885	990	1100	1205				
50 km/h			720	840	955	1075	1190	1310				
65 km/h			690	800	915	1025	1140	1250				

* Se référer aux remarques en fin des tableaux de cette gamme

MICHELIN OMNIBIB

Caractéristiques & Pression en bar / psi – Charges par pneu en kg*

Ø pouces	Description	CAI	e mm	D mm	R' mm	Cdr mm	Jante(s) recommandée(s)	Jante(s) tolérée(s)	Chambre à air (Code)	Volume interne 75% (litres)	Profond. de sculpture (mm)
24	360/70R24 122D TL	198698	373	1153	513	3418	W11	W10 W12L	692	137	43
Bar	0.4	0.5	0.6	0.8	1	1.2	1.4	1.6	1.8	1.9	2
Psi	6	7	9	12	15	17	20	23	26	28	29
10 km/h	1040	1115	1190	1345	1495	1645	1795	1950	2100	2175	2250
30 km/h	790	870	945	1105	1260	1415	1575	1730			
40 km/h			900	1050	1195	1345	1490	1640			
40 km/h Dual	665	730	795	925	1055	1185	1315	1445			
50 km/h			870	1010	1155	1295	1440	1580			
65 km/h			825	960	1095	1230	1365	1500			

Ø pouces	Description	CAI	e mm	D mm	R' mm	Cdr mm	Jante(s) recommandée(s)	Jante(s) tolérée(s)	Chambre à air (Code)	Volume interne 75% (litres)	Profond. de sculpture (mm)
24	380/70R24 125D TL	085816	399	1188	528	3520	W12	W11 W13	700	161	45
Bar	0.4	0.5	0.6	0.8	1	1.2	1.4	1.6	1.8	1.9	2
Psi	6	7	9	12	15	17	20	23	26	28	29
10 km/h	1130	1215	1300	1470	1635	1805	1975	2145	2310	2395	2480
30 km/h	860	945	1035	1205	1380	1555	1725	1900			
40 km/h			990	1155	1320	1480	1645	1810			
40 km/h Dual	725	795	865	1010	1155	1300	1445	1590			
50 km/h			950	1105	1260	1420	1575	1730			
65 km/h			900	1050	1200	1350	1500	1650			

Ø pouces	Description	CAI	e mm	D mm	R' mm	Cdr mm	Jante(s) recommandée(s)	Jante(s) tolérée(s)	Chambre à air (Code)	Volume interne 75% (litres)	Profond. de sculpture (mm)
24	420/70R24 130D TL	829095	436	1251	553	3702	W13	W12L DW14L W14L	703	203	46
Bar	0.4	0.5	0.6	0.8	1	1.2	1.4	1.6	1.8	1.9	2
Psi	6	7	9	12	15	17	20	23	26	28	29
10 km/h	1310	1405	1505	1695	1890	2080	2275	2465	2660	2755	2850
30 km/h	1010	1110	1205	1405	1600	1795	1995	2190			
40 km/h			1130	1320	1510	1700	1890	2080			
40 km/h Dual	845	920	995	1160	1330	1495	1665	1830			
50 km/h			1080	1265	1450	1630	1815	2000			
65 km/h			1030	1205	1380	1550	1725	1900			

* Se référer aux remarques en fin des tableaux de cette gamme

MICHELIN OMNIBIB

Caractéristiques & Pression en bar / psi – Charges par pneu en kg*

Ø pouces	Description	CAI	e mm	D mm	R' mm	Cdr mm	Jante(s) recommandée(s)	Jante(s) tolérée(s)	Chambre à air (Code)	Volume interne 75% (litres)	Profond. de sculpture (mm)
24	480/70R24 138D TL	375821	494	1327	578	3916	DW15L	DW14L W14L W15L DW16L W16L	710	276	48
Bar	0.4	0.5	0.6	0.8	1	1.2	1.4	1.6	1.8	1.9	2
Psi	6	7	9	12	15	17	20	23	26	28	29
10 km/h	1590	1710	1835	2080	2320	2565	2810	3055	3295	3420	3540
30 km/h	1220	1345	1470	1715	1965	2215	2460	2710			
40 km/h			1410	1645	1880	2110	2345	2580			
40 km/h Dual	1020	1130	1240	1445	1655	1860	2070	2275			
50 km/h			1350	1575	1800	2030	2255	2480			
65 km/h			1285	1500	1715	1930	2145	2360			

Ø pouces	Description	CAI	e mm	D mm	R' mm	Cdr mm	Jante(s) recommandée(s)	Jante(s) tolérée(s)	Chambre à air (Code)	Volume interne 75% (litres)	Profond. de sculpture (mm)
28	380/70R28 127D TL	118587	390	1294	580	3842	W12	W11 W13	732	179	45
Bar	0.4	0.5	0.6	0.8	1	1.2	1.4	1.6	1.8	1.9	2
Psi	6	7	9	12	15	17	20	23	26	28	29
10 km/h	1200	1290	1380	1560	1735	1915	2095	2275	2450	2540	2630
30 km/h	920	1010	1100	1285	1465	1645	1830	2010			
40 km/h			1040	1215	1390	1570	1745	1920			
40 km/h Dual	770	845	915	1070	1225	1375	1530	1685			
50 km/h			1000	1170	1335	1505	1670	1840			
65 km/h			950	1110	1270	1430	1590	1750			

Ø pouces	Description	CAI	e mm	D mm	R' mm	Cdr mm	Jante(s) recommandée(s)	Jante(s) tolérée(s)	Chambre à air (Code)	Volume interne 75% (litres)	Profond. de sculpture (mm)
28	420/70R28 133D TL	532215	436	1354	602	4012	W13	W12 DW14L W14L	821	231	46
Bar	0.4	0.5	0.6	0.8	1	1.2	1.4	1.6	1.8	1.9	2
Psi	6	7	9	12	15	17	20	23	26	28	29
10 km/h	1390	1495	1605	1815	2030	2240	2455	2665	2880	2985	3090
30 km/h	1060	1170	1280	1495	1715	1935	2150	2370			
40 km/h			1230	1435	1640	1850	2055	2260			
40 km/h Dual	890	985	1080	1260	1440	1625	1805	1985			
50 km/h			1180	1375	1570	1770	1965	2160			
65 km/h			1120	1310	1495	1685	1870	2060			

* Se référer aux remarques en fin des tableaux de cette gamme

MICHELIN OMNIBIB

Caractéristiques & Pression en bar / psi – Charges par pneu en kg*

Ø pouces	Description	CAI	e mm	D mm	R' mm	Cdr mm	Jante(s) recommandée(s)	Jante(s) tolérée(s)	Chambre à air (Code)	Volume interne 75% (litres)	Profond. de sculpture (mm)
28	480/70R28 140D TL	570026	500	1427	632	4217	DW15L	DW14L W14L W15L DW16L W16L	822	302	48
Bar	0.4	0.5	0.6	0.8	1	1.2	1.4	1.6	1.8	1.9	2
Psi	6	7	9	12	15	17	20	23	26	28	29
10 km/h	1730	1855	1985	2235	2490	2740	2995	3245	3500	3625	3750
30 km/h	1320	1450	1580	1840	2100	2360	2620	2880			
40 km/h			1490	1740	1990	2240	2490	2740			
40 km/h Dual	1110	1210	1310	1530	1750	1970	2190	2410			
50 km/h			1430	1670	1910	2150	2390	2630			
65 km/h			1360	1590	1815	2045	2270	2500			

Ø pouces	Description	CAI	e mm	D mm	R' mm	Cdr mm	Jante(s) recommandée(s)	Jante(s) tolérée(s)	Chambre à air (Code)	Volume interne 75% (litres)	Profond. de sculpture (mm)
30	480/70R30 141D TL	599351	498	1482	656	4388	DW15L	DW14L W14L W15L DW16L W16L	754	317	48
Bar	0.4	0.5	0.6	0.8	1	1.2	1.4	1.6	1.8	1.9	2
Psi	6	7	9	12	15	17	20	23	26	28	29
10 km/h	1770	1900	2030	2295	2555	2815	3075	3340	3600	3730	3860
30 km/h	1360	1495	1625	1895	2160	2425	2695	2960			
40 km/h			1530	1790	2045	2305	2560	2820			
40 km/h Dual	1135	1245	1350	1575	1800	2030	2255	2480			
50 km/h			1470	1715	1960	2210	2455	2700			
65 km/h			1400	1635	1870	2105	2340	2575			

Ø pouces	Description	CAI	e mm	D mm	R' mm	Cdr mm	Jante(s) recommandée(s)	Jante(s) tolérée(s)	Chambre à air (Code)	Volume interne 75% (litres)	Profond. de sculpture (mm)
34	480/70R34 143D TL	280033	497	1593	713	4728	DW15L	DW14L W14L W15L DW16L W16L	704	345	50
Bar	0.4	0.5	0.6	0.8	1	1.2	1.4	1.6	1.8	1.9	2
Psi	6	7	9	12	15	17	20	23	26	28	29
10 km/h	1880	2020	2155	2435	2710	2985	3260	3540	3815	3950	4090
30 km/h	1440	1580	1720	2005	2285	2565	2850	3130			
40 km/h			1640	1910	2175	2445	2710	2980			
40 km/h Dual	1205	1325	1445	1680	1915	2155	2390	2625			
50 km/h			1580	1835	2090	2350	2605	2860			
65 km/h			1500	1745	1990	2235	2480	2725			

* Se référer aux remarques en fin des tableaux de cette gamme

MICHELIN OMNIBIB

Caractéristiques & Pression en bar / psi – Charges par pneu en kg*

Ø pouces	Description	CAI	e mm	D mm	R' mm	Cdr mm	Jante(s) recommandée(s)	Jante(s) tolérée(s)	Chambre à air (Code)	Volume interne 75% (litres)	Profond. de sculpture (mm)
34	520/70R34 148D TL	939411	535	1651	730	4887	DW16L	DW15L W15L W16L DW18L W18L	823	422	53
Bar	0.4	0.5	0.6	0.8	1	1.2	1.4	1.6	1.8	1.9	2
Psi	6	7	9	12	15	17	20	23	26	28	29
10 km/h	2100	2265	2430	2760	3085	3415	3745	4075	4400	4565	4730
30 km/h	1610	1780	1945	2280	2615	2950	3285	3620			
40 km/h			1860	2180	2495	2815	3130	3450			
40 km/h Dual	1350	1495	1640	1920	2200	2475	2755	3035			
50 km/h			1790	2095	2400	2700	3005	3310			
65 km/h			1700	1990	2280	2570	2860	3150			

Ø pouces	Description	CAI	e mm	D mm	R' mm	Cdr mm	Jante(s) recommandée(s)	Jante(s) tolérée(s)	Chambre à air (Code)	Volume interne 75% (litres)	Profond. de sculpture (mm)
38	480/70R38 145D TL	936570	498	1694	759	5030	DW15L	DW14L W14L W15L DW16L W16L	786	377	52
Bar	0.4	0.5	0.6	0.8	1	1.2	1.4	1.6	1.8	1.9	2
Psi	6	7	9	12	15	17	20	23	26	28	29
10 km/h	1980	2130	2275	2575	2870	3165	3460	3760	4055	4200	4350
30 km/h	1520	1670	1825	2125	2430	2735	3035	3340			
40 km/h			1750	2035	2320	2610	2895	3180			
40 km/h Dual	1270	1405	1540	1790	2040	2295	2545	2795			
50 km/h			1680	1955	2230	2500	2775	3050			
65 km/h			1600	1860	2120	2380	2640	2900			

Ø pouces	Description	CAI	e mm	D mm	R' mm	Cdr mm	Jante(s) recommandée(s)	Jante(s) tolérée(s)	Chambre à air (Code)	Volume interne 75% (litres)	Profond. de sculpture (mm)
38	520/70R38 150D TL	833744	539	1766	782	5229	DW16L	DW15L W15L W16L DW18L W18L	824	464	53
Bar	0.4	0.5	0.6	0.8	1	1.2	1.4	1.6	1.8	1.9	2
Psi	6	7	9	12	15	17	20	23	26	28	29
10 km/h	2250	2425	2600	2945	3295	3640	3990	4335	4685	4855	5030
30 km/h	1730	1905	2085	2435	2790	3145	3495	3850			
40 km/h			1970	2310	2650	2990	3330	3670			
40 km/h Dual	1445	1590	1735	2035	2335	2630	2930	3230			
50 km/h			1890	2215	2540	2870	3195	3520			
65 km/h			1800	2110	2420	2730	3040	3350			

* Se référer aux remarques en fin des tableaux de cette gamme

MICHELIN OMNIBIB

Caractéristiques & Pression en bar / psi – Charges par pneu en kg*

Ø pouces	Description	CAI	e mm	D mm	R' mm	Cdr mm	Jante(s) recommandée(s)	Jante(s) tolérée(s)	Chambre à air (Code)	Volume interne 75% (litres)	Profond. de sculpture (mm)
38	580/70R38 155D TL	001240	601	1836	815	5440	DW18L	W18L	825	590	56
Bar	0.4	0.5	0.6	0.8	1	1.2	1.4	1.6	1.8	1.9	2
Psi	6	7	9	12	15	17	20	23	26	28	29
10 km/h	2630	2830	3030	3425	3825	4220	4620	5015	5415	5610	5810
30 km/h	2010	2215	2420	2825	3235	3645	4050	4460			
40 km/h			2320	2705	3090	3470	3855	4240			
40 km/h Dual	1685	1865	2045	2385	2720	3060	3395	3735			
50 km/h			2230	2600	2965	3335	3700	4070			
65 km/h			2120	2470	2820	3175	3525	3875			

Ø pouces	Description	CAI	e mm	D mm	R' mm	Cdr mm	Jante(s) recommandée(s)	Jante(s) tolérée(s)	Chambre à air (Code)	Volume interne 75% (litres)	Profond. de sculpture (mm)
42	620/70R42 160D TL	989457	639	1953	863	5781	DW20B (A)	DW18L	802	658	58
Bar	0.4	0.5	0.6	0.8	1	1.2	1.4	1.6	1.8	1.9	2
Psi	6	7	9	12	15	17	20	23	26	28	29
10 km/h	3090	3320	3550	4005	4465	4920	5380	5835	6295	6520	6750
30 km/h	2370	2605	2840	3305	3775	4245	4710	5180			
40 km/h			2660	3115	3570	4020	4475	4930			
40 km/h Dual	1985	2165	2340	2740	3140	3535	3935	4335			
50 km/h			2550	2985	3420	3860	4295	4730			
65 km/h			2430	2845	3260	3670	4085	4500			

***REMARQUES**

La pression de gonflage se détermine toujours en fonction de la charge par pneu, de la vitesse et du travail à réaliser.

Nos préconisations ci-dessus sont fournies sous réserve de modifications postérieures à la date de diffusion de ces tableaux (mars 2021).

Les données techniques sont susceptibles d'évoluer sans information préalable.

- Pour un usage labour et d'autres usages champ sous couple élevé, utiliser la ligne 30 km/h.
- Lors d'un usage en monte simple :
 - Pour usage en dévers >20% : ajouter 0,4 bar.
 - Pour usage routier intensif >50% : ajouter 0,4 bar.



MICHELIN YELDBIB

LE PNEU BASSE PRESSION
POUR LES UTILISATIONS
DE FORTE PUISSANCE POUR
LES CULTURES EN LIGNE



POUR TRACTEURS de 160 à 550 CV



VF Très basse pression



Protection des sols **+25% de surface de contact** ⁽¹⁾



Plus de **traction** avec 2 barrettes supplémentaires
et un design à 45° ⁽²⁾



PRODUCTIVITÉ
Même capacité de charge avec une **pression de gonflage réduite de 40%**

(1) Test Michelin 2016, VF 480/80 R50 Yieldbib vs 480/80 R50 AGRIBIB.

(2) Comparé aux pneus standards des concurrents ayant des rainures à 23°

DIMENSIONS

VF 380/85R34 149A8/149B TL
VF 420/85R34 154A8/154B TL
VF 380/80R38 149A8/149B TL
VF 380/95R38 154A8/154B TL
VF 480/80R46 164A8/164B TL
VF 480/80R50 166A8/166B TL
VF 480/95R50 170A8/170B TL

MICHELIN YELDBIB

Caractéristiques & Pression en bar / psi – Charges par pneu en kg*

Ø pouces	Description	CAI	e mm	D mm	R' mm	Cdr mm	Jante(s) recommandée(s)	Jante(s) tolérée(s)	Chambre à air (Code)	Volume interne 75% (litres)	Profond. de sculpture (mm)		
34	VF 380/85R34 149A8/149B TL	305457	372	1510	668	4471	W13	W12	704	230	44		
Bar	0.4	0.5	0.6	0.7	0.8	0.9	1	1.1	1.2	1.3	1.4	1.5	1.6
Psi	6	7	9	10	12	13	15	16	17	19	20	22	23
10 km/h	1595	1760	1925	2090	2255	2420	2585	2750	2915	3080	3245	3410	3575
30 km/h	1480	1635	1785	1940	2090	2245	2400	2550	2705	2860	3010	3165	3315
30 km/h Dual	1300	1435	1570	1705	1840	1975	2110	2245	2380	2515	2650	2780	2915
30 km/h Triple	1215	1340	1465	1590	1715	1840	1970	2095	2220	2345	2470	2595	2720
50 km/h	1450	1600	1750	1900	2050	2200	2350	2500	2650	2800	2950	3100	3250
50 km/h Dual	1280	1410	1545	1675	1805	1940	2070	2205	2335	2465	2600	2730	2860
50 km/h Triple	1190	1315	1435	1560	1680	1805	1930	2050	2175	2300	2420	2545	2665

Ø pouces	Description	CAI	e mm	D mm	R' mm	Cdr mm	Jante(s) recommandée(s)	Jante(s) tolérée(s)	Chambre à air (Code)	Volume interne 75% (litres)	Profond. de sculpture (mm)		
34	VF 420/85R34 154A8/154B TL	012445	432	1582	699	4682	DW15L	W13 W14L W15A (L) DW14A (L)	704	287	48		
Bar	0.4	0.5	0.6	0.7	0.8	0.9	1	1.1	1.2	1.3	1.4	1.5	1.6
Psi	6	7	9	10	12	13	15	16	17	19	20	22	23
10 km/h	1870	2060	2250	2440	2630	2820	3010	3195	3385	3570	3755	3940	4125
30 km/h	1735	1910	2090	2265	2440	2615	2790	2960	3135	3310	3480	3655	3825
30 km/h Dual	1525	1680	1835	1990	2145	2300	2455	2605	2760	2910	3065	3215	3365
30 km/h Triple	1425	1570	1715	1855	2000	2145	2285	2430	2570	2710	2855	2995	3135
50 km/h	1700	1875	2045	2220	2390	2560	2735	2905	3075	3245	3415	3580	3750
50 km/h Dual	1500	1650	1805	1955	2105	2255	2405	2555	2705	2855	3005	3150	3300
50 km/h Triple	1395	1535	1680	1820	1960	2100	2240	2380	2520	2660	2800	2935	3075

Ø pouces	Description	CAI	e mm	D mm	R' mm	Cdr mm	Jante(s) recommandée(s)	Jante(s) tolérée(s)	Chambre à air (Code)	Volume interne 75% (litres)	Profond. de sculpture (mm)		
38	VF 380/80R38 149A8/149B TL	870363	366	1592	711	4851	DW12A	W12 W13	796 795	230	45		
Bar	0.4	0.5	0.6	0.7	0.8	0.9	1	1.1	1.2	1.3	1.4	1.5	1.6
Psi	6	7	9	10	12	13	15	16	17	19	20	22	23
10 km/h	1595	1760	1930	2095	2260	2425	2590	2755	2920	3085	3250	3410	3575
30 km/h	1480	1635	1790	1940	2095	2250	2405	2555	2710	2860	3015	3165	3315
30 km/h Dual	1300	1435	1575	1710	1845	1980	2115	2250	2385	2520	2650	2785	2915
30 km/h Triple	1215	1340	1470	1595	1720	1845	1970	2095	2220	2345	2470	2595	2720
50 km/h	1450	1600	1755	1905	2055	2205	2355	2505	2655	2805	2955	3100	3250
50 km/h Dual	1280	1415	1550	1680	1815	1945	2080	2210	2340	2470	2600	2730	2860
50 km/h Triple	1190	1315	1440	1560	1685	1810	1935	2055	2180	2300	2425	2545	2665

* Se référer aux remarques en fin des tableaux de cette gamme

MICHELIN YELDBIB

Caractéristiques & Pression en bar / psi – Charges par pneu en kg*

Ø pouces	Description	CAI	e mm	D mm	R' mm	Cdr mm	Jante(s) recommandée(s)	Jante(s) tolérée(s)	Chambre à air (Code)	Volume interne 75% (litres)	Profond. de sculpture (mm)		
38	VF 380/95R38 154A8/154B TL	873023	377	1703	755	5044	DW12A	W12	795 796	286	47		
Bar	0.4	0.5	0.6	0.7	0.8	0.9	1	1.1	1.2	1.3	1.4	1.5	1.6
Psi	6	7	9	10	12	13	15	16	17	19	20	22	23
10 km/h	1870	2060	2250	2435	2625	2810	3000	3185	3370	3560	3750	3935	4125
30 km/h	1735	1910	2085	2260	2435	2610	2780	2955	3125	3300	3475	3650	3825
30 km/h Dual	1525	1680	1835	1990	2145	2295	2450	2600	2750	2905	3060	3210	3365
30 km/h Triple	1425	1570	1710	1855	1995	2140	2280	2425	2565	2710	2850	2995	3135
50 km/h	1700	1870	2045	2215	2385	2555	2725	2895	3065	3235	3410	3580	3750
50 km/h Dual	1500	1650	1800	1950	2100	2250	2400	2550	2700	2850	3000	3150	3300
50 km/h Triple	1400	1540	1680	1815	1955	2095	2235	2375	2515	2655	2795	2935	3075

Ø pouces	Description	CAI	e mm	D mm	R' mm	Cdr mm	Jante(s) recommandée(s)	Jante(s) tolérée(s)	Chambre à air (Code)	Volume interne 75% (litres)	Profond. de sculpture (mm)		
46	VF 480/80R46 164A8/164B TL	842300	480	1933	861	5732	DW16A	DW16L W16A DW15L DW16B	834	449	52		
Bar	0.4	0.5	0.6	0.7	0.8	0.9	1	1.1	1.2	1.3	1.4	1.5	1.6
Psi	6	7	9	10	12	13	15	16	17	19	20	22	23
10 km/h	2530	2780	3025	3275	3520	3770	4015	4265	4510	4760	5005	5255	5500
30 km/h	2345	2575	2805	3035	3265	3495	3725	3950	4180	4410	4640	4870	5100
30 km/h Dual	2065	2270	2470	2675	2875	3075	3280	3480	3680	3885	4085	4290	4490
30 km/h Triple	1925	2115	2300	2490	2675	2865	3055	3240	3430	3620	3805	3995	4180
50 km/h	2300	2525	2750	2975	3200	3425	3650	3875	4100	4325	4550	4775	5000
50 km/h Dual	2025	2225	2420	2620	2815	3015	3215	3410	3610	3810	4005	4205	4400
50 km/h Triple	1885	2070	2255	2440	2625	2810	2995	3175	3360	3545	3730	3915	4100

Ø pouces	Description	CAI	e mm	D mm	R' mm	Cdr mm	Jante(s) recommandée(s)	Jante(s) tolérée(s)	Chambre à air (Code)	Volume interne 75% (litres)	Profond. de sculpture (mm)		
50	VF 480/80R50 166A8/166B TL	309830	468	2039	901	6034	DW16A(L)	DW15L DW15B (A) W15B (A) DW16B W16B		479	49		
Bar	0.4	0.5	0.6	0.7	0.8	0.9	1	1.1	1.2	1.3	1.4	1.5	1.6
Psi	6	7	9	10	12	13	15	16	17	19	20	22	23
10 km/h	2595	2855	3115	3375	3635	3895	4155	4415	4675	4965	5255	5540	5830
30 km/h	2405	2645	2890	3130	3370	3610	3855	4095	4335	4605	4870	5140	5405
30 km/h Dual	2115	2330	2540	2755	2965	3180	3390	3605	3815	4050	4285	4520	4755
30 km/h Triple	1970	2170	2370	2565	2765	2965	3160	3360	3555	3775	3995	4210	4430
50 km/h	2360	2595	2835	3070	3305	3540	3780	4015	4250	4515	4775	5040	5300
50 km/h Dual	2075	2285	2495	2700	2910	3120	3325	3535	3740	3970	4200	4430	4660
50 km/h Triple	1930	2125	2320	2515	2710	2905	3100	3295	3490	3705	3920	4135	4350

* Se référer aux remarques en fin des tableaux de cette gamme

MICHELIN YIELDBIB

Caractéristiques & Pression en bar / psi – Charges par pneu en kg*

Ø pouces	Description	CAI	e mm	D mm	R' mm	Cdr mm	Jante(s) recommandée(s)		Jante(s) tolérée(s)		Chambre à air (Code)	Volume interne 75% (litres)	Profond. de sculpture (mm)
50	VF 480/95R50 170A8/170B TL	252129	477	2186	962	6464	DW16L		DW15L (NRO) W15L (NRO) W16L			593	51
Bar	0.4	0.5	0.6	0.7	0.8	0.9	1	1.1	1.2	1.3	1.4	1.5	1.6
Psi	6	7	9	10	12	13	15	16	17	19	20	22	23
10 km/h	3000	3315	3625	3940	4250	4565	4875	5190	5500	5775	6050	6325	6600
30 km/h	2780	3070	3360	3650	3940	4230	4520	4810	5100	5355	5610	5865	6120
30 km/h Dual	2445	2700	2955	3210	3465	3720	3980	4235	4490	4715	4940	5160	5385
30 km/h Triple	2280	2520	2755	2995	3230	3470	3705	3945	4180	4390	4600	4810	5020
50 km/h	2725	3010	3295	3580	3865	4150	4435	4715	5000	5250	5500	5750	6000
50 km/h Dual	2400	2650	2900	3150	3400	3650	3900	4150	4400	4620	4840	5060	5280
50 km/h Triple	2235	2470	2705	2935	3170	3405	3635	3870	4100	4305	4510	4715	4920

*REMARQUES

La pression de gonflage se détermine toujours en fonction de la charge par pneu, de la vitesse et du travail à réaliser.
 Nos préconisations ci-dessus sont fournies sous réserve de modifications postérieures à la date de diffusion de ces tableaux (mars 2021).
 Les données techniques sont susceptibles d'évoluer sans information préalable.

- Lors d'un usage en monte simple :
 - Pour usage en dévers >20% : ajouter 0,4 bar.
 - Pour usage routier intensif >50% : ajouter 0,4 bar.
- (NRO) - Narrow Rim Option. Ajouter 0,2 bar en cas de montage sur une jante NRO.

TRACTEURS

FORTE PUISSANCE



MICHELIN AGRIBIB 2

**UN HAUT NIVEAU DE
PERFORMANCE TOUT AU
LONG DE SON CYCLE DE VIE**



POUR TRACTEURS jusqu'à 220 CV
et jusqu'à 500 CV en montage jumelé (42", 46", 50")



**UNE EXCELLENTE TRACTION TOUT AU LONG
DE SON CYCLE DE VIE**

- +4%⁽¹⁾ pneus neufs
- +22%⁽¹⁾ lorsqu'à 60% d'usure



LONGÉVITÉ grâce à des barrettes profondes
Sculpture jusqu'à 8% plus profonde que l'offre R1W
des concurrents principaux⁽¹⁾



ROBUSTESSE
Indice de charge jusqu'à 18% supérieur⁽²⁾



(1) Test d'analyse piste centre d'essais MICHELIN de Ladoux - Dimension 18.4 R38

(2) Selon les dimensions et pour la dimensions 520/85 R46 164A8/164B

DIMENSIONS

480/80R26 149A8/149B TL

280/85R28 123A8/120D TL

380/85R30 140A8/140B TL

420/90R30 147A8/147B TL

650/75R32 167A8/167B TL

320/85R34 133A8/133B TL

380/85R34 142A8/142B TL

420/85R34 147A8/147B TL

380/80R38 142A8/139D TL

420/85R38 149A8/149B TL

520/85R38 160A8/160B TL

480/80R42 156A8/156B TL

520/85R42 162A8/162B TL

420/80R46 151A8/151B TL

480/80R46 158A8/158B TL

520/85R46 164A8/164B TL

480/80R50 159A8/159B TL

380/90R54 152A8/152B TL

MICHELIN AGRIBIB 2

Caractéristiques & Pression en bar / psi – Charges par pneu en kg*

Ø pouces	Description	CAI	e mm	D mm	R' mm	Cdr mm	Jante(s) recommandée(s)	Jante(s) tolérée(s)	Chambre à air (Code)	Volume interne 75% (litres)	Profond. de sculpture (mm)
26	480/80R26 149A8/149B TL <i>Amérique du Sud</i>	466081	500	1416	633	4202	DW16B(A)	DW15B(A)		297	51.5
Bar	0.4 0.6 0.8 1 1.2 1.4 1.6 1.8 2 2.2 2.4 2.6 2.8										
Psi	6 9 12 15 17 20 23 26 29 32 35 38 41										
10 km/h	1875 2245 2620 2990 3360 3555 3750 3975 4200 4370 4540 4705 4875										
30 km/h	1340 1605 1875 2135 2395 2655 2915 3055 3200 3340 3480										
40 km/h	1500 1750 1995 2240 2485 2725 2855 2990 3120 3250										
40 km/h Dual	1320 1540 1755 1970 2185 2400 2515 2630 2745 2860										
50 km/h	1500 1750 1995 2240 2485 2725 2855 2990 3120 3250										

Ø pouces	Description	CAI	e mm	D mm	R' mm	Cdr mm	Jante(s) recommandée(s)	Jante(s) tolérée(s)	Chambre à air (Code)	Volume interne 75% (litres)	Profond. de sculpture (mm)
28	280/85R28 123A8/120D TL	392931	299	1192	545	3563	W10	W9	725	98	40
Bar	0.4 0.6 0.8 1 1.2 1.4 1.6 1.8 2 2.2 2.4 2.6 2.8										
Psi	6 9 12 15 17 20 23 26 29 32 35 38 41										
10 km/h	900 1075 1245 1420 1590 1680 1770 1905 2040 2110 2185 2255 2325										
30 km/h	640 760 885 1010 1135 1275 1410 1475 1535 1600 1660										
40 km/h	710 825 945 1060 1190 1320 1380 1435 1495 1550										
40 km/h Dual	625 725 830 935 1050 1160 1210 1265 1315 1365										
50 km/h	645 750 860 965 1085 1200 1255 1305 1360 1410										
65 km/h	645 750 860 965 1085 1200 1255 1305 1360 1410										

Ø pouces	Description	CAI	e mm	D mm	R' mm	Cdr mm	Jante(s) recommandée(s)	Jante(s) tolérée(s)	Chambre à air (Code)	Volume interne 75% (litres)	Profond. de sculpture (mm)
30	380/85R30 140A8/140B TL <i>14.9 R30</i>	151572	394	1416	644	4219	W12	W13	734	229	46.5
Bar	0.4 0.6 0.8 1 1.2 1.4 1.6 1.8 2 2.2 2.4 2.6 2.8										
Psi	6 9 12 15 17 20 23 26 29 32 35 38 41										
10 km/h	1465 1755 2045 2335 2625 2775 2925 3145 3360 3460 3555 3655 3750										
30 km/h	1045 1265 1455 1665 1875 2105 2335 2420 2505 2590 2675										
40 km/h	1180 1360 1555 1750 1965 2180 2260 2340 2420 2500										
40 km/h Dual	1040 1195 1370 1540 1730 1920 1990 2060 2130 2200										
50 km/h	1180 1360 1555 1750 1965 2180 2260 2340 2420 2500										

* Se référer aux remarques en fin des tableaux de cette gamme

MICHELIN AGRIBIB 2

Caractéristiques & Pression en bar / psi – Charges par pneu en kg*

Ø pouces	Description	CAI	e mm	D mm	R' mm	Cdt mm	Jante(s) recommandée(s)	Jante(s) tolérée(s)	Chambre à air (Code)	Volume interne 75% (litres)	Profond. de sculpture (mm)		
30	420/90R30 147A8/147B TL <i>16,9 R30</i>	508522	418	1518	684	4513	DW13	W13 DW14L W14L	754	284	50		
Bar	0.4 0.6 0.8	1	1.2	1.4	1.6	1.8	2	2.2	2.4	2.6	2.8		
Psi	6 9 12	15	17	20	23	26	29	32	35	38	41		
10 km/h	1825	2120	2420	2715	3015	3310	3605	3905	4200	4305	4410	4510	4615
30 km/h	1300	1550	1810	2075	2335	2585	2835	2970	3105	3200	3290		
40 km/h		1450	1700	1940	2180	2415	2650	2775	2900	2990	3075		
40 km/h Dual	1070	1275	1495	1710	1920	2125	2330	2425	2520	2610	2705		
50 km/h		1450	1700	1940	2180	2415	2650	2775	2900	2990	3075		

Ø pouces	Description	CAI	e mm	D mm	R' mm	Cdt mm	Jante(s) recommandée(s)	Jante(s) tolérée(s)	Chambre à air (Code)	Volume interne 75% (litres)	Profond. de sculpture (mm)		
32	650/75R32 167A8/167B TL <i>Amérique du Sud</i>	533727	667	1827	811	5395	DW20B (A)	DW21B (A)	831	647	49		
Bar	0.4 0.6 0.8	1	1.2	1.4	1.6	1.8	2	2.2	2.4	2.6	2.8		
Psi	6 9 12	15	17	20	23	26	29	32	35	38	41		
10 km/h	3180	3840	4500	5155	5815	6095	6375	6750	7125	7390	7650	7915	8175
30 km/h	2270	2755	3210	3680	4145	4550	4950	5170	5390	5610	5830		
40 km/h		2575	3000	3440	3875	4250	4625	4830	5040	5245	5450		
40 km/h Dual		2265	2640	3025	3410	3740	4070	4250	4435	4615	4795		
50 km/h		2575	3000	3440	3875	4250	4625	4830	5040	5245	5450		

Ø pouces	Description	CAI	e mm	D mm	R' mm	Cdt mm	Jante(s) recommandée(s)	Jante(s) tolérée(s)	Chambre à air (Code)	Volume interne 75% (litres)	Profond. de sculpture (mm)		
34	320/85R34 133A8/133B TL <i>12,4 R34</i>	908266	312	1421	653	4243	W10			155	44		
Bar	0.4 0.6 0.8	1	1.2	1.4	1.6	1.8	2	2.2	2.4	2.6	2.8		
Psi	6 9 12	15	17	20	23	26	29	32	35	38	41		
10 km/h	1200	1445	1690	1930	2175	2290	2400	2550	2700	2800	2895	2995	3090
30 km/h	855	1045	1200	1375	1550	1715	1875	1960	2040	2125	2205		
40 km/h		975	1120	1285	1450	1600	1750	1830	1905	1985	2060		
40 km/h Dual	705	860	985	1130	1275	1410	1540	1610	1680	1745	1815		
50 km/h		975	1120	1285	1450	1600	1750	1830	1905	1985	2060		

* Se référer aux remarques en fin des tableaux de cette gamme

MICHELIN AGRIBIB 2

Caractéristiques & Pression en bar / psi – Charges par pneu en kg*

Ø pouces	Description	CAI	e mm	D mm	R' mm	Cdr mm	Jante(s) recommandée(s)	Jante(s) tolérée(s)	Chambre à air (Code)	Volume interne 75% (litres)	Profond. de sculpture (mm)
34	380/85R34 142A8/142B TL 14.9 R34	009860	378	1516	691	4519	W12	W13	704	286	46.5
Bar	0.4 0.6 0.8 1 1.2 1.4 1.6 1.8 2 2.2 2.4 2.6 2.8										
Psi	6 9 12 15 17 20 23 26 29 32 35 38 41										
10 km/h	1545 1855 2160 2470 2775 2935 3090 3315 3540 3650 3760 3865 3975										
30 km/h	1100 1340 1550 1765 1980 2220 2460 2555 2650 2740 2835										
40 km/h	1250 1450 1650 1850 2075 2300 2390 2475 2565 2650										
40 km/h Dual	1100 1275 1455 1630 1830 2025 2100 2180 2255 2330										
50 km/h	1250 1450 1650 1850 2075 2300 2390 2475 2565 2650										

Ø pouces	Description	CAI	e mm	D mm	R' mm	Cdr mm	Jante(s) recommandée(s)	Jante(s) tolérée(s)	Chambre à air (Code)	Volume interne 75% (litres)	Profond. de sculpture (mm)
34	420/85R34 147A8/147B TL 16.9 R34	183733	449	1589	720	4730	DW15L	W13 DW14L W14L W15L	704	287	48.5
Bar	0.4 0.6 0.8 1 1.2 1.4 1.6 1.8 2 2.2 2.4 2.6 2.8										
Psi	6 9 12 15 17 20 23 26 29 32 35 38 41										
10 km/h	1300 1795 2285 2780 3270 3460 3645 3870 4090 4220 4355 4485 4615										
30 km/h	1300 1550 1820 2080 2325 2585 2835 2950 3065 3175 3290										
40 km/h	1450 1700 1940 2180 2415 2650 2755 2865 2970 3075										
40 km/h Dual	1070 1275 1495 1710 1920 2125 2330 2425 2520 2610 2705										
50 km/h	1450 1700 1940 2180 2415 2650 2755 2865 2970 3075										

Ø pouces	Description	CAI	e mm	D mm	R' mm	Cdr mm	Jante(s) recommandée(s)	Jante(s) tolérée(s)	Chambre à air (Code)	Volume interne 75% (litres)	Profond. de sculpture (mm)
38	380/80R38 142A8/139D TL 14.9 R38	187095	380	1595	729	4755	DW12A	W11 DW12 W12 W13 DW13 DW11	795 796	230	46
Bar	0.4 0.6 0.8 1 1.2 1.4 1.6 1.8 2 2.2 2.4 2.6 2.8										
Psi	6 9 12 15 17 20 23 26 29 32 35 38 41										
10 km/h	1545 1870 2200 2525 2850 2970 3090 3315 3540 3650 3760 3865 3975										
30 km/h	1100 1340 1550 1795 2035 2250 2460 2555 2650 2740 2835										
40 km/h	1250 1450 1675 1900 2100 2300 2390 2475 2565 2650										
40 km/h Dual	1100 1275 1475 1670 1850 2025 2100 2180 2255 2330										
50 km/h	1250 1450 1675 1900 2100 2300 2390 2475 2565 2650										
65 km/h	1140 1320 1525 1730 1915 2095 2175 2255 2330 2410										

* Se référer aux remarques en fin des tableaux de cette gamme

MICHELIN AGRIBIB 2

Caractéristiques & Pression en bar / psi – Charges par pneu en kg*

Ø pouces	Description	CAI	e mm	D mm	R' mm	Cdr mm	Jante(s) recommandée(s)	Jante(s) tolérée(s)	Chambre à air (Code)	Volume interne 75% (litres)	Profond. de sculpture (mm)		
38	420/85R38 149A8/149B TL 16.9 R38	048439	450	1690	769	5035	DW15L	DW14L W14L W15L	786	293	49		
Bar	0.4	0.6	0.8	1	1.2	1.4	1.6	1.8	2	2.2	2.4	2.6	2.8
Psi	6	9	12	15	17	20	23	26	29	32	35	38	41
10 km/h	1930	2250	2575	2895	3215	3535	3860	4180	4500	4595	4690	4780	4875
30 km/h	1375	1660	1925	2195	2460	2730	2995	3145	3290	3385	3480		
40 km/h		1550	1800	2050	2300	2550	2800	2940	3075	3165	3250		
40 km/h Dual	1130	1365	1585	1805	2025	2245	2465	2565	2665	2760	2860		
50 km/h		1550	1800	2050	2300	2550	2800	2940	3075	3165	3250		

Ø pouces	Description	CAI	e mm	D mm	R' mm	Cdr mm	Jante(s) recommandée(s)	Jante(s) tolérée(s)	Chambre à air (Code)	Volume interne 75% (litres)	Profond. de sculpture (mm)		
38	520/85R38 160A8/160B TL 20.8 R38	882358	533	1849	831	5493	DW16L	DD16 W16A DD18 DW18L W18A	825	508	55		
Bar	0.4	0.6	0.8	1	1.2	1.4	1.6	1.8	2	2.2	2.4	2.6	2.8
Psi	6	9	12	15	17	20	23	26	29	32	35	38	41
10 km/h	2625	3070	3515	3960	4410	4855	5300	5745	6190	6330	6470	6610	6750
30 km/h	1875	2270	2635	3005	3370	3760	4145	4350	4550	4685	4815		
40 km/h		2120	2500	2825	3150	3515	3875	4065	4250	4375	4500		
40 km/h Dual	1540	1865	2200	2485	2770	3090	3410	3550	3685	3825	3960		
50 km/h		2120	2500	2825	3150	3515	3875	4065	4250	4375	4500		

Ø pouces	Description	CAI	e mm	D mm	R' mm	Cdr mm	Jante(s) recommandée(s)	Jante(s) tolérée(s)	Chambre à air (Code)	Volume interne 75% (litres)	Profond. de sculpture (mm)		
42	480/80R42 156A8/156B TL 18.4 R42	539386	489	1840	837	5470	DW16A	DD16 W16A	801	412	52		
Bar	0.4	0.6	0.8	1	1.2	1.4	1.6	1.8	2	2.2	2.4	2.6	2.8
Psi	6	9	12	15	17	20	23	26	29	32	35	38	41
10 km/h	2325	2720	3115	3505	3900	4295	4690	5080	5475	5605	5740	5870	6000
30 km/h	1660	1980	2320	2655	2995	3345	3690	3855	4015	4150	4280		
40 km/h		1850	2180	2490	2800	3125	3450	3600	3750	3875	4000		
40 km/h Dual	1365	1630	1920	2195	2465	2750	3035	3155	3280	3400	3520		
50 km/h		1850	2180	2490	2800	3125	3450	3600	3750	3875	4000		

* Se référer aux remarques en fin des tableaux de cette gamme

MICHELIN AGRIBIB 2

Caractéristiques & Pression en bar / psi – Charges par pneu en kg*

Ø pouces	Description	CAI	e mm	D mm	R' mm	Cdr mm	Jante(s) recommandée(s)	Jante(s) tolérée(s)	Chambre à air (Code)	Volume interne 75% (litres)	Profond. de sculpture (mm)		
42	520/85R42 162A8/162B TL <i>20.8 R42</i>	405859	542	1958	886	5810	DW18A	DW16A DW16L W16A TW16L DD18 W18A W16L	802	545	55		
Bar	0.4	0.6	0.8	1	1.2	1.4	1.6	1.8	2	2.2	2.4	2.6	2.8
Psi	6	9	12	15	17	20	23	26	29	32	35	38	41
10 km/h	2775	3250	3725	4195	4670	5145	5620	6090	6565	6705	6845	6985	7125
30 km/h	1980	2395	2790	3190	3585	4000	4415	4615	4815	4950	5085		
40 km/h		2240	2575	2965	3350	3740	4125	4315	4500	4625	4750		
40 km/h Dual	1630	1970	2265	2610	2950	3290	3630	3770	3905	4045	4180		
50 km/h		2240	2575	2965	3350	3740	4125	4315	4500	4625	4750		

Ø pouces	Description	CAI	e mm	D mm	R' mm	Cdr mm	Jante(s) recommandée(s)	Jante(s) tolérée(s)	Chambre à air (Code)	Volume interne 75% (litres)	Profond. de sculpture (mm)		
46	420/80R46 151A8/151B TL	885138	410	1854	844	5524	DW13	DW12	835	334	50		
Bar	0.4	0.6	0.8	1	1.2	1.4	1.6	1.8	2	2.2	2.4	2.6	2.8
Psi	6	9	12	15	17	20	23	26	29	32	35	38	41
10 km/h	1980	2395	2815	3230	3645	3810	3975	4240	4500	4670	4840	5005	5175
30 km/h	1410	1710	1980	2290	2600	2855	3105	3250	3400	3545	3690		
40 km/h		1600	1850	2140	2430	2665	2900	3040	3175	3315	3450		
40 km/h Dual	1160	1410	1630	1885	2140	2345	2550	2670	2795	2915	3035		
50 km/h		1600	1850	2140	2430	2665	2900	3040	3175	3315	3450		

Ø pouces	Description	CAI	e mm	D mm	R' mm	Cdr mm	Jante(s) recommandée(s)	Jante(s) tolérée(s)	Chambre à air (Code)	Volume interne 75% (litres)	Profond. de sculpture (mm)		
46	480/80R46 158A8/158B TL <i>18.4 R46</i>	622709	486	1945	891	5804	DW16A	DD16 DW16L W16A	834	449	52		
Bar	0.4	0.6	0.8	1	1.2	1.4	1.6	1.8	2	2.2	2.4	2.6	2.8
Psi	6	9	12	15	17	20	23	26	29	32	35	38	41
10 km/h	2475	2945	3415	3880	4350	4615	4875	5175	5475	5700	5925	6150	6375
30 km/h	1765	2085	2460	2785	3105	3455	3800	3990	4175	4365	4550		
40 km/h		1950	2300	2600	2900	3225	3550	3725	3900	4075	4250		
40 km/h Dual	1715	2025	2290	2550	2840	3125	3280	3435	3585	3740			
50 km/h		1950	2300	2600	2900	3225	3550	3725	3900	4075	4250		

* Se référer aux remarques en fin des tableaux de cette gamme

MICHELIN AGRIBIB 2

Caractéristiques & Pression en bar / psi – Charges par pneu en kg*

Ø pouces	Description	CAI	e mm	D mm	R' mm	Cdr mm	Jante(s) recommandée(s)		Jante(s) tolérée(s)	Chambre à air (Code)	Volume interne 75% (litres)	Profond. de sculpture (mm)														
46	520/85R46 164A8/164B TL <i>20.8 R46</i>	120922	518	2059	931	6110	DW16A		DW16L W16A TW16L DW18L W18L W16L W18A DW18A	834	560	55														
													Bar	0.4	0.6	0.8	1	1.2	1.4	1.6	1.8	2	2.2	2.4	2.6	2.8
													Psi	6	9	12	15	17	20	23	26	29	32	35	38	41
													10 km/h	2925	3425	3930	4430	4935	5435	5935	6440	6940	7035	7130	7220	7315
													30 km/h	2085	2460	2870	3280	3690	4120	4550	4750	4950	5150	5350		
													40 km/h		2300	2725	3090	3450	3850	4250	4440	4625	4815	5000		
													40 km/h Dual	1715	2025	2400	2720	3035	3390	3740	3905	4070	4235	4400		
													50 km/h		2300	2725	3090	3450	3850	4250	4440	4625	4815	5000		

Ø pouces	Description	CAI	e mm	D mm	R' mm	Cdr mm	Jante(s) recommandée(s)		Jante(s) tolérée(s)	Chambre à air (Code)	Volume interne 75% (litres)	Profond. de sculpture (mm)														
50	480/80R50 159A8/159B TL	263049	465	2050	938	6116	DW15A		DW16A		483	52														
													Bar	0.4	0.6	0.8	1	1.2	1.4	1.6	1.8	2	2.2	2.4	2.6	2.8
													Psi	6	9	12	15	17	20	23	26	29	32	35	38	41
													10 km/h	2550	3065	3585	4100	4615	4895	5175	5495	5815	6005	6190	6380	6565
													30 km/h	1820	2205	2525	2910	3290	3655	4015	4180	4350	4515	4680		
													40 km/h		2060	2360	2720	3075	3415	3750	3905	4065	4220	4375		
													40 km/h Dual	1815	2075	2390	2705	3005	3300	3440	3575	3715	3850			
													50 km/h		2060	2360	2720	3075	3415	3750	3905	4065	4220	4375		

Ø pouces	Description	CAI	e mm	D mm	R' mm	Cdr mm	Jante(s) recommandée(s)		Jante(s) tolérée(s)	Chambre à air (Code)	Volume interne 75% (litres)	Profond. de sculpture (mm)														
54	380/90R54 152A8/152B TL	075615	386	2054	949	6129	W12A		DW13B		334	50														
													Bar	0.4	0.6	0.8	1	1.2	1.4	1.6	1.8	2	2.2	2.4	2.6	2.8
													Psi	6	9	12	15	17	20	23	26	29	32	35	38	41
													10 km/h	2040	2470	2895	3325	3750	3920	4090	4410	4725	4875	5025	5175	5325
													30 km/h	1455	1765	2085	2380	2675	2945	3210	3360	3505	3655	3800		
													40 km/h		1650	1950	2225	2500	2750	3000	3140	3275	3415	3550		
													40 km/h Dual	1450	1715	1960	2200	2420	2640	2760	2885	3005	3125			
													50 km/h		1650	1950	2225	2500	2750	3000	3140	3275	3415	3550		

* Se référer aux remarques en fin des tableaux de cette gamme

MICHELIN AGRIBIB 2

Caractéristiques & Pression en bar / psi – Charges par pneu en kg*

*REMARQUES

La pression de gonflage se détermine toujours en fonction de la charge par pneu, de la vitesse et du travail à réaliser.
Nos préconisations ci-dessus sont fournies sous réserve de modifications postérieures à la date de diffusion de ces tableaux (mars 2021).
Les données techniques sont susceptibles d'évoluer sans information préalable.

- Pour un usage labour et d'autres usages champ sous couple élevé, utiliser la ligne 30 km/h.
- Lors d'un usage en monte simple :
 - Pour usage en dévers >20% : ajouter 0,4 bar.
 - Pour usage routier intensif >50% : ajouter 0,4 bar.



MICHELIN AGRIBIB

**UN HAUT NIVEAU DE
PERFORMANCE TOUT AU
LONG DE SON CYCLE DE VIE**



POUR TRACTEURS jusqu'à **220 CV**
et jusqu'à **500 CV** en montage jumelé (42", 46", 50")



UNE TRACTION EXCELLENTE tout au long de son cycle de vie

- +4%⁽¹⁾ pneus neufs
- +22%⁽¹⁾ jusqu'à 60% d'usure



LONGÉVITÉ grâce à des barrettes profondes



ROBUSTESSE :

- Endurance de la carcasse radiale éprouvée
- Caoutchouc résistant aux dégradations

(1) Test d'analyse piste Centre d'essais MICHELIN de Ladoux - Dimension 18.4 R38

DIMENSIONS

9.5R24 112A8/109B TL	16.9R28 141A8/138B TL	12.4R36 124A8/121B TL	520/85R42 157A8/157B TL
11.2R24 119A8/116B TL	380/85R30 135A8/135B TL	12.4R38 131A8/128B TL	420/80R46 151A8/148B TL
12.4R24 119A8/116B TL	16.9R30 137A8/134B TL	13.6R38 128A8/125B TL	480/80R46 158A8/158B TL
13.6R24 124A8/121B TL	420/90R30 147A8/147B TL	420/85R38 144A8/144B TL	520/85R46 158A8/155B TL
14.9R24 130A8/127B TL	18.4R30 142A8/139B TL	380/95R38 147A8/147B TL	480/80R50 159A8/159B TL
16.9R24 134A8/131B TL	320/85R34 133A8/130B TL	18.4R38 151A8/148B TL	480/95R50 164A8/164B TL
12.4R28 126A8/123B TL	380/85R34 137A8/137B TL	20.8R38 159A8/156B TL	
13.6R28 123A8/120B TL	420/85R34 147A8/147B TL	520/85R38 155A8/155B TL	
14.9R28 134A8/131B TL	18.4R34 149A8/146B TL	480/80R42 156A8/156B TL	

MICHELIN AGRIBIB

Caractéristiques & Pression en bar / psi – Charges par pneu en kg*

Ø pouces	Description	CAI	e mm	D mm	R' mm	Cdr mm	Jante(s) recommandée(s)		Jante(s) tolérée(s)		Chambre à air (Code)	Volume interne 75% (litres)	Profond. de sculpture (mm)
24	9.5R24 112A8/109B TL	200987	253	1045	481	3117	W8		W7		686	65	32
Bar	0.4	0.5	0.6	0.8	1	1.2	1.4	1.6	1.8	2	2.1	2.3	2.4
Psi	6	7	9	12	15	17	20	23	26	29	30	33	35
10 km/h	675	745	815	960	1100	1240	1280	1315	1395	1475	1515	1595	1635
30 km/h	535	605	675	745	815	885	965	1045	1105	1170	1200		
40 km/h			630	695	760	825	900	975	1035	1090	1120		
40 km/h Dual	385	470	555	615	675	740	800	860	910	960	985		
50 km/h			575	640	710	775	830	885	940	995	1020		

Ø pouces	Description	CAI	e mm	D mm	R' mm	Cdr mm	Jante(s) recommandée(s)		Jante(s) tolérée(s)		Chambre à air (Code)	Volume interne 75% (litres)	Profond. de sculpture (mm)
24	11.2R24 119A8/116B TL	317247	288	1095	503	3269	W10		W9		692	92	37
Bar	0.4	0.5	0.6	0.8	1	1.2	1.4	1.6	1.8	2	2.1	2.3	2.4
Psi	6	7	9	12	15	17	20	23	26	29	30	33	35
10 km/h	840	925	1005	1170	1335	1500	1570	1635	1720	1810	1850	1935	1980
30 km/h	660	745	830	910	990	1070	1170	1265	1340	1415	1455		
40 km/h			775	850	925	1000	1090	1180	1250	1325	1360		
40 km/h Dual	480	580	680	750	825	895	970	1040	1100	1165	1195		
50 km/h			705	780	860	935	1005	1075	1140	1205	1240		

Ø pouces	Description	CAI	e mm	D mm	R' mm	Cdr mm	Jante(s) recommandée(s)		Jante(s) tolérée(s)		Chambre à air (Code)	Volume interne 75% (litres)	Profond. de sculpture (mm)
24	12.4R24 119A8/116B TL	123788	324	1149	520	3420	W11		W10		692	116	41
Bar	0.5	0.6	0.8	1	1.2	1.4	1.6	1.8					
Psi	7	9	12	15	17	20	23	26					
10 km/h	1040	1200	1330	1460	1590	1715	1845	1975					
30 km/h	810	950	1050	1155	1255	1360	1460						
40 km/h		880	975	1070	1170	1265	1360						
50 km/h		830	915	1000	1080	1165	1250						

* Se référer aux remarques en fin des tableaux de cette gamme

MICHELIN AGRIBIB

Caractéristiques & Pression en bar / psi – Charges par pneu en kg*

Ø pouces	Description	CAI	e mm	D mm	R' mm	Cdr mm	Jante(s) recommandée(s)	Jante(s) tolérée(s)	Chambre à air (Code)	Volume interne 75% (litres)	Profond. de sculpture (mm)			
24	13.6R24 124A8/121B TL	262831	370	1200	551	3583	W12	W11	700	144	43			
Bar	0.4	0.5	0.6	0.8	1	1.2	1.4	1.6	1.8	2	2.1	2.3	2.4	2.6
Psi	6	7	9	12	15	17	20	23	26	29	30	33	35	38
10 km/h	975	1075	1175	1375	1570	1770	1850	1930	2030	2130	2175	2275	2325	
30 km/h	760	865	965	1065	1165	1265	1385	1500	1585	1670	1710			
40 km/h			900	995	1085	1180	1290	1400	1480	1560	1600			
40 km/h Dual	555	675	790	880	965	1055	1140	1230	1300	1375	1410			
40 km/h FRT								1550	1680	1775	1825	1920	1960	2040
50 km/h		820	915	1010	1105	1190	1275	1345	1420	1455				

Ø pouces	Description	CAI	e mm	D mm	R' mm	Cdr mm	Jante(s) recommandée(s)	Jante(s) tolérée(s)	Chambre à air (Code)	Volume interne 75% (litres)	Profond. de sculpture (mm)			
24	14.9R24 130A8/127B TL	601563	397	1265	575	3769	W13	W11 W12	703	188	48			
Bar	0.4	0.5	0.6	0.8	1	1.2	1.4	1.6	1.8	2	2.1	2.3	2.4	
Psi	6	7	9	12	15	17	20	23	26	29	30	33	35	
10 km/h	1165	1280	1400	1635	1865	2100	2175	2250	2380	2515	2580	2710	2775	
30 km/h	910	1040	1165	1275	1390	1500	1635	1765	1875	1980	2035			
40 km/h			1090	1195	1295	1400	1525	1650	1750	1850	1900			
40 km/h Dual	660	810	960	1060	1155	1255	1350	1450	1540	1625	1670			
50 km/h		990	1100	1210	1320	1410	1500	1590	1685	1730				

Ø pouces	Description	CAI	e mm	D mm	R' mm	Cdr mm	Jante(s) recommandée(s)	Jante(s) tolérée(s)	Chambre à air (Code)	Volume interne 75% (litres)	Profond. de sculpture (mm)
24	16.9R24 134A8/131B TL	123854	460	1330	586	3935	DW15L	DW14L W14L W15L	710	244	55
Bar	0.4	0.5	0.6	0.8	1	1.2	1.4	1.6	1.8		
Psi	6	7	9	12	15	17	20	23	26		
10 km/h		1620	1880	2080	2280	2480	2680	2880	3080		
30 km/h		1270	1470	1630	1790	1950	2110	2270			
40 km/h			1380	1530	1675	1825	1970	2120			
40 km/h Dual	790	1005	1215	1345	1475	1605	1735	1865			
50 km/h		1290	1420	1555	1685	1820	1950				

* Se référer aux remarques en fin des tableaux de cette gamme

MICHELIN AGRIBIB

Caractéristiques & Pression en bar / psi – Charges par pneu en kg*

Ø pouces	Description	CAI	e mm	D mm	R' mm	Cdr mm	Jante(s) recommandée(s)		Jante(s) tolérée(s)		Chambre à air (Code)	Volume interne 75% (litres)	Profond. de sculpture (mm)
28	12.4R28 126A8/123B TL	738964	322	1265	586	3778	W11		W10		726	134	40
Bar	0.4	0.5	0.6	0.8	1	1.2	1.4	1.6	1.8	2	2.1	2.3	2.4
Psi	6	7	9	12	15	17	20	23	26	29	30	33	35
10 km/h	1035	1140	1245	1455	1665	1875	1960	2040	2150	2260	2310	2420	2475
30 km/h	805	925	1045	1145	1240	1340	1475	1605	1690	1775	1820		
40 km/h			975	1065	1160	1250	1375	1500	1580	1660	1700		
40 km/h Dual	590	725	860	950	1045	1135	1230	1320	1390	1460	1495		
50 km/h			885	980	1075	1170	1270	1365	1435	1510	1545		

Ø pouces	Description	CAI	e mm	D mm	R' mm	Cdr mm	Jante(s) recommandée(s)		Jante(s) tolérée(s)		Chambre à air (Code)	Volume interne 75% (litres)	Profond. de sculpture (mm)
28	13.6R28 123A8/120B TL	123782	372	1308	592	3893	W12		W11		732	173	46
Bar	0.4	0.5	0.6	0.8	1	1.2	1.4	1.6	1.8				
Psi	6	7	9	12	15	17	20	23	26				
10 km/h		1190	1370	1520	1665	1815	1960	2110	2255				
30 km/h	930	1080	1195	1310	1430	1545	1660						
40 km/h			1010	1120	1225	1335	1440	1550					
40 km/h Dual	590	740	890	985	1080	1175	1270	1365					
50 km/h			920	1015	1110	1210	1305	1400					

Ø pouces	Description	CAI	e mm	D mm	R' mm	Cdr mm	Jante(s) recommandée(s)		Jante(s) tolérée(s)		Chambre à air (Code)	Volume interne 75% (litres)	Profond. de sculpture (mm)		
28	14.9R28 134A8/131B TL	112235	393	1365	624	4072	W13		W12		821	210	47		
Bar	0.4	0.5	0.6	0.8	1	1.2	1.4	1.6	1.8	2	2.1	2.3	2.4	2.6	2.8
Psi	6	7	9	12	15	17	20	23	26	29	30	33	35	38	41
10 km/h	1240	1365	1495	1745	2000	2250	2365	2475	2625	2775	2825	2925	2980	3080	3180
30 km/h	885	980	1070	1230	1420	1605	1765	1925	2010	2100	2140	2225	2270		
40 km/h			1000	1150	1325	1500	1650	1800	1880	1960	2000	2080	2120		
50 km/h			910	1045	1205	1365	1505	1640	1715	1785	1820	1895	1930		

* Se référer aux remarques en fin des tableaux de cette gamme

MICHELIN AGRIBIB

Caractéristiques & Pression en bar / psi – Charges par pneu en kg*

Ø pouces	Description	CAI	e mm	D mm	R' mm	Cdr mm	Jante(s) recommandée(s)		Jante(s) tolérée(s)	Chambre à air (Code)	Volume interne 75% (litres)	Profond. de sculpture (mm)			
28	16.9R28 141A8/1388 TL	984997	454	1435	655	4278	DW15L		DW14L W14L W15L	822	272	51			
Bar	0.4	0.5	0.6	0.8	1	1.2	1.4	1.6	1.8	2	2.1	2.3	2.4	2.6	2.8
Psi	6	7	9	12	15	17	20	23	26	29	30	33	35	38	41
10 km/h	1500	1650	1800	2100	2400	2700	2850	3000	3180	3360	3425	3550	3615	3740	3865
30 km/h	1070	1185	1300	1500	1715	1925	2130	2335	2440	2545	2600	2705	2755		
40 km/h				1215	1400	1600	1800	1990	2180	2280	2380	2425	2525	2575	
50 km/h				1105	1275	1460	1640	1815	1985	2075	2165	2210	2300	2345	

Ø pouces	Description	CAI	e mm	D mm	R' mm	Cdr mm	Jante(s) recommandée(s)		Jante(s) tolérée(s)	Chambre à air (Code)	Volume interne 75% (litres)	Profond. de sculpture (mm)
30	380/85R30 135A8/1358 TL	836509	386	1416	628	4194	W12		W13	734	209	46
Bar	0.4	0.5	0.6	0.8	1	1.2	1.4	1.6	1.8			
Psi	6	7	9	12	15	17	20	23	26			
10 km/h	1450	1565	1680	1905	2135	2360	2580	2800	3100			
30 km/h	1060	1155	1250	1450	1675	1900	2100	2300				
40 km/h				1180	1360	1555	1750	1965	2180			
40 km/h Dual	860	950	1040	1195	1370	1540	1730	1920				
50 km/h				1180	1360	1550	1750	1965	2180			

Ø pouces	Description	CAI	e mm	D mm	R' mm	Cdr mm	Jante(s) recommandée(s)		Jante(s) tolérée(s)	Chambre à air (Code)	Volume interne 75% (litres)	Profond. de sculpture (mm)
30	16.9R30 137A8/1348 TL	123870	447	1480	664	4395	DW15L		DW14L W14L W15L	754	285	49
Bar	0.4	0.5	0.6	0.8	1	1.2	1.4	1.6	1.8			
Psi	6	7	9	12	15	17	20	23	26			
10 km/h		1760	2040	2255	2475	2690	2910	3125	3340			
30 km/h		1380	1600	1770	1945	2115	2290	2460				
40 km/h			1500	1660	1820	1980	2140	2300				
40 km/h Dual	880	1100	1320	1460	1600	1745	1885	2025				
50 km/h			1400	1545	1690	1830	1975	2120				

* Se référer aux remarques en fin des tableaux de cette gamme

MICHELIN AGRIBIB

Caractéristiques & Pression en bar / psi – Charges par pneu en kg*

Ø pouces	Description	CAI	e mm	D mm	R' mm	Cdr mm	Jante(s) recommandée(s)		Jante(s) tolérée(s)	Chambre à air (Code)	Volume interne 75% (litres)	Profond. de sculpture (mm)			
30	420/90R30 147A8/147B TL	953332	443	1533	690	4556	DW13		W13 DW14L W14L	754	284	44			
Bar	0.4	0.5	0.6	0.8	1	1.2	1.4	1.6	1.8	2	2.1	2.3	2.4	2.6	2.8
Psi	6	7	9	12	15	17	20	23	26	29	30	33	35	38	41
10 km/h	1800	1955	2110	2415	2725	3035	3340	3650	3950	4250	4315	4440	4500	4565	4625
30 km/h	1285	1420	1550	1800	2050	2300	2550	2800	2940	3075	3145	3280	3350		
40 km/h				1450	1700	1940	2175	2415	2650	2775	2900	2945	3030	3075	
40 km/h Dual	1070	1175	1275	1495	1705	1915	2120	2330	2440	2550	2590	2665	2705		
50 km/h				1450	1700	1940	2175	2415	2650	2775	2900	2945	3030	3075	

Ø pouces	Description	CAI	e mm	D mm	R' mm	Cdr mm	Jante(s) recommandée(s)		Jante(s) tolérée(s)	Chambre à air (Code)	Volume interne 75% (litres)	Profond. de sculpture (mm)
30	18.4R30 142A8/139B TL	123844	504	1550	695	4602	DW16L		DW15L W15L W16L	757	353	54
Bar	0.4	0.5	0.6	0.8	1	1.2	1.4	1.6	1.8			
Psi	6	7	9	12	15	17	20	23	26			
10 km/h		2030	2350	2600	2850	3100	3355	3605	3855			
30 km/h		1590	1840	2040	2240	2440	2640	2840				
40 km/h				1720	1905	2090	2280	2465	2650			
40 km/h Dual	1040	1280	1515	1680	1840	2005	2165	2330				
50 km/h				1600	1765	1930	2100	2265	2430			

Ø pouces	Description	CAI	e mm	D mm	R' mm	Cdr mm	Jante(s) recommandée(s)		Jante(s) tolérée(s)	Chambre à air (Code)	Volume interne 75% (litres)	Profond. de sculpture (mm)			
34	320/85R34 133A8/130B TL	122760	320	1420	651	4239	W10				155	39			
Bar	0.4	0.5	0.6	0.8	1	1.2	1.4	1.6	1.8	2	2.1	2.3	2.4	2.6	2.8
Psi	6	7	9	12	15	17	20	23	26	29	30	33	35	38	41
10 km/h	1215	1315	1410	1610	1805	2000	2215	2430	2615	2800	2835	2905	2940	3005	3075
30 km/h	850	940	1030	1215	1385	1550	1725	1900	1980	2060	2090	2150	2180		
40 km/h				975	1120	1285	1450	1600	1750	1850	1950	1980	2035	2060	
40 km/h Dual	705	785	860	985	1130	1275	1410	1540	1630	1715	1740	1790	1815		
50 km/h				900	1030	1180	1320	1460	1600	1700	1800	1825	1875	1900	

* Se référer aux remarques en fin des tableaux de cette gamme

MICHELIN AGRIBIB

Caractéristiques & Pression en bar / psi – Charges par pneu en kg*

Ø pouces	Description	CAI	e mm	D mm	R' mm	Cdr mm	Jante(s) recommandée(s)	Jante(s) tolérée(s)	Chambre à air (Code)	Volume interne 75% (litres)	Profond. de sculpture (mm)
34	380/85R34 137A8/137B TL	122781	394	1503	673	4461	W12	W13	704	230	44
Bar	0.4	0.5	0.6	0.8	1	1.2	1.4	1.6	1.8		
Psi	6	7	9	12	15	17	20	23	26		
10 km/h	1550	1670	1790	2025	2265	2500	2750	3000	3300		
30 km/h	1120	1220	1320	1550	1775	2000	2215	2430			
40 km/h			1250	1450	1650	1850	2075	2300			
40 km/h Dual	905	1005	1100	1275	1455	1630	1830	2025			
50 km/h			1250	1450	1650	1850	2075	2300			

Ø pouces	Description	CAI	e mm	D mm	R' mm	Cdr mm	Jante(s) recommandée(s)	Jante(s) tolérée(s)	Chambre à air (Code)	Volume interne 75% (litres)	Profond. de sculpture (mm)				
34	420/85R34 147A8/147B TL	788910	455	1595	725	4751	DW15L	W13 DW14L W14L W15L	704	287	51				
Bar	0.4	0.5	0.6	0.8	1	1.2	1.4	1.6	1.8	2	2.1	2.3	2.4	2.6	2.8
Psi	6	7	9	12	15	17	20	23	26	29	30	33	35	38	41
10 km/h	1800	1940	2075	2350	2625	2900	3175	3450	3800	4045	4115	4260	4330	4475	4615
30 km/h	1300	1430	1560	1815	2075	2330	2585	2835	2950	3065	3120	3235	3290		
40 km/h			1450	1695	1935	2180	2415	2650	2755	2865	2915	3020	3075		
40 km/h Dual			1280	1495	1705	1920	2125	2330	2425	2520	2570	2665	2710		
50 km/h			1450	1695	1935	2180	2415	2650	2755	2865	2915	3020	3075		

Ø pouces	Description	CAI	e mm	D mm	R' mm	Cdr mm	Jante(s) recommandée(s)	Jante(s) tolérée(s)	Chambre à air (Code)	Volume interne 75% (litres)	Profond. de sculpture (mm)		
34	18.4R34 149A8/146B TL	679786	491	1662	747	4940	DW16L	DW15L W15L W16L	823	395	54		
Bar	0.4	0.5	0.6	0.8	1	1.2	1.4	1.6	1.8	2	2.1	2.3	2.4
Psi	6	7	9	12	15	17	20	23	26	29	30	33	35
10 km/h	1980	2175	2370	2760	3150	3540	3705	3865	4080	4295	4405	4620	4725
30 km/h	1550	1765	1980	2160	2345	2525	2760	2995	3190	3385	3480		
40 km/h			1850	2020	2190	2360	2580	2800	2980	3160	3250		
40 km/h Dual	1130	1380	1630	1795	1965	2130	2300	2465	2625	2780	2860		
50 km/h			1685	1860	2035	2210	2380	2550	2715	2880	2960		

* Se référer aux remarques en fin des tableaux de cette gamme

MICHELIN AGRIBIB

Caractéristiques & Pression en bar / psi – Charges par pneu en kg*

Ø pouces	Description	CAI	e mm	D mm	R' mm	Cdr. mm	Jante(s) recommandée(s)	Jante(s) tolérée(s)	Chambre à air (Code)	Volume interne 75% (litres)	Profond. de sculpture (mm)
36	12.4R36 124A8/121B TL	123952	318	1460	673	4363	W11	W10	779	165	33
Bar	0.5	0.6	0.8	1	1.2	1.4	1.6	1.8			
Psi	7	9	12	15	17	20	23	26			
10 km/h	1220	1420	1570	1720	1870	2025	2175	2325			
30 km/h	960	1110	1230	1350	1470	1590	1710				
40 km/h		1040	1150	1265	1375	1490	1600				
50 km/h		960	1060	1155	1255	1350	1450				

Ø pouces	Description	CAI	e mm	D mm	R' mm	Cdr. mm	Jante(s) recommandée(s)	Jante(s) tolérée(s)	Chambre à air (Code)	Volume interne 75% (litres)	Profond. de sculpture (mm)		
38	12.4R38 131A8/128B TL	258138	325	1500	697	4484	W11	DW10 W10	779	165	35		
Bar	0.4	0.5	0.6	0.8	1	1.2	1.4	1.6	1.8	2	2.1	2.3	2.4
Psi	6	7	9	12	15	17	20	23	26	29	30	33	35
10 km/h	1200	1315	1425	1650	1875	2100	2215	2325	2440	2550	2605	2720	2775
30 km/h	935	1070	1200	1300	1400	1500	1660	1820	1925	2030	2085		
40 km/h			1120	1215	1305	1400	1550	1700	1800	1900	1950		
40 km/h Dual	680	835	985	1085	1190	1290	1395	1495	1585	1670	1715		
50 km/h			1020	1120	1220	1320	1435	1545	1635	1730	1775		

Ø pouces	Description	CAI	e mm	D mm	R' mm	Cdr. mm	Jante(s) recommandée(s)	Jante(s) tolérée(s)	Chambre à air (Code)	Volume interne 75% (litres)	Profond. de sculpture (mm)
38	13.6R38 128A8/125B TL	123992	358	1565	722	4705	DW12	W11 W12	795	218	45
Bar	0.4	0.5	0.6	0.8	1	1.2	1.4	1.6	1.8		
Psi	6	7	9	12	15	17	20	23	26		
10 km/h		1380	1590	1760	1930	2100	2275	2445	2615		
30 km/h		1080	1250	1385	1520	1660	1795	1930			
40 km/h			1030	1140	1250	1365	1475	1585			
40 km/h Dual	685	860	1030	1140	1250	1365	1475	1585			
50 km/h			1090	1200	1315	1425	1540	1650			

* Se référer aux remarques en fin des tableaux de cette gamme

MICHELIN AGRIBIB

Caractéristiques & Pression en bar / psi – Charges par pneu en kg*

Ø pouces	Description	CAI	e mm	D mm	R' mm	Cdr mm	Jante(s) recommandée(s)		Jante(s) tolérée(s)	Chambre à air (Code)	Volume interne 75% (litres)	Profond. de sculpture (mm)
38	420/85R38 144A8/144B TL	607820	455	1676	750	4975	DW15L		DW14L W14L W15L	786	311	51
Bar	0.4	0.5	0.6	0.8	1	1.2	1.4	1.6	1.8			
Psi	6	7	9	12	15	17	20	23	26			
10 km/h	1900	2045	2190	2485	2775	3065	3360	3650	4015			
30 km/h	1375	1510	1645	1915	2190	2460	2730	3000				
40 km/h			1550	1800	2050	2300	2550	2800				
40 km/h Dual	1130	1240	1355	1575	1800	2020	2245	2465				
50 km/h			1550	1800	2050	2300	2550	2800				
max 40 km/h FRT				2160	2460	2760	3060	3360				

Ø pouces	Description	CAI	e mm	D mm	R' mm	Cdr mm	Jante(s) recommandée(s)		Jante(s) tolérée(s)	Chambre à air (Code)	Volume interne 75% (litres)	Profond. de sculpture (mm)			
38	380/95R38 147A8/147B TL	836033	392	1689	769	5034	W12		W13	795	286	47			
Bar	0.4	0.5	0.6	0.8	1	1.2	1.4	1.6	1.8	2	2.1	2.3	2.4	2.6	2.8
Psi	6	7	9	12	15	17	20	23	26	29	30	33	35	38	41
10 km/h	1825	1980	2130	2440	2745	3055	3360	3670	3975	4100	4165	4295	4355	4485	4610
30 km/h	1300	1430	1555	1810	2070	2325	2580	2835	2950	3065	3120	3235	3290		
40 km/h			1450	1690	1930	2170	2410	2650	2755	2865	2915	3020	3075		
40 km/h Dual	1070	1150	1235	1395	1560	1725	1890	2050	2215	2380	2460	2625	2705		
50 km/h			1450	1690	1930	2170	2410	2650	2755	2865	2915	3020	3075		

Ø pouces	Description	CAI	e mm	D mm	R' mm	Cdr mm	Jante(s) recommandée(s)		Jante(s) tolérée(s)	Chambre à air (Code)	Volume interne 75% (litres)	Profond. de sculpture (mm)	
38	18.4R38 151A8/148B TL	100097	494	1770	800	5267	DW16L		DW15L W15L W16L	824	431	54	
Bar	0.4	0.5	0.6	0.8	1	1.2	1.4	1.6	1.8	2	2.1	2.3	2.4
Psi	6	7	9	12	15	17	20	23	26	29	30	33	35
10 km/h	2100	2305	2515	2925	3340	3750	3920	4090	4325	4560	4675	4910	5025
30 km/h	1660	1875	2085	2280	2480	2675	2945	3210	3400	3595	3690		
40 km/h			1950	2135	2315	2500	2750	3000	3180	3360	3450		
40 km/h Dual	1195	1455	1715	1900	2085	2270	2455	2640	2800	2955	3035		
50 km/h			1775	1965	2155	2345	2540	2730	2895	3060	3140		

* Se référer aux remarques en fin des tableaux de cette gamme

MICHELIN AGRIBIB

Caractéristiques & Pression en bar / psi – Charges par pneu en kg*

Ø pouces	Description	CAI	e mm	D mm	R' mm	Cdr mm	Jante(s) recommandée(s)	Jante(s) tolérée(s)	Chambre à air (Code)	Volume interne 75% (litres)	Profond. de sculpture (mm)				
38	20.8R38 159A8/1568 TL	813266	541	1850	837	5506	DW18L	DW16L W16L W18L	825	524	57				
Bar	0.4	0.5	0.6	0.8	1	1.2	1.4	1.6	1.8	2	2.1	2.3	2.4	2.6	2.8
Psi	6	7	9	12	15	17	20	23	26	29	30	33	35	38	41
10 km/h	2550	2810	3065	3585	4100	4615	4895	5175	5495	5815	5910	6095	6190	6380	6565
30 km/h	1820	2015	2205	2525	2910	3290	3655	4015	4180	4350	4430	4595	4680		
40 km/h			2060	2360	2720	3075	3415	3750	3905	4065	4140	4295	4375		
40 km/h Dual			1810	2075	2390	2705	3005	3300	3440	3575	3645	3780	3850		
50 km/h			1875	2150	2475	2800	3110	3415	3555	3700	3770	3910	3980		

Ø pouces	Description	CAI	e mm	D mm	R' mm	Cdr mm	Jante(s) recommandée(s)	Jante(s) tolérée(s)	Chambre à air (Code)	Volume interne 75% (litres)	Profond. de sculpture (mm)
38	520/85R38 155A8/1558 TL	303668	530	1855	821	5529	DW16L	DD16 DW16A W16A DD18 W18A	825	509	51
Bar	0.4	0.5	0.6	0.8	1	1.2	1.4	1.6	1.8		
Psi	6	7	9	12	15	17	20	23	26		
10 km/h	2650	2850	3050	3450	3850	4250	4625	5000	5535		
30 km/h	1900	2100	2300	2650	3050	3450	3790	4125			
40 km/h			2120	2500	2825	3150	3515	3875			
40 km/h Dual	1540	1705	1865	2200	2485	2770	3090	3410			
50 km/h			2120	2500	2800	3160	3515	3875			
max 40 km/h FRT				3000	3415	3825	4240	4650			

Ø pouces	Description	CAI	e mm	D mm	R' mm	Cdr mm	Jante(s) recommandée(s)	Jante(s) tolérée(s)	Chambre à air (Code)	Volume interne 75% (litres)	Profond. de sculpture (mm)				
42	480/80R42 156A8/1568 TL	404096	494	1858	847	5538	DW16A	DD16 W16A	801	420	55				
Bar	0.4	0.5	0.6	0.8	1	1.2	1.4	1.6	1.8	2	2.1	2.3	2.4	2.6	2.8
Psi	6	7	9	12	15	17	20	23	26	29	30	33	35	38	41
10 km/h	2325	2505	2690	3050	3415	3775	4140	4500	4750	5000	5125	5375	5500	5750	6000
30 km/h	1660	1830	2000	2335	2675	3015	3350	3690	3840	3985	4060	4205	4280		
40 km/h			1850	2170	2490	2810	3130	3450	3590	3725	3795	3930	4000		
40 km/h Dual	1320	1465	1605	1890	2180	2465	2750	3035	3155	3280	3340	3460	3520		
50 km/h			1850	2170	2490	2810	3130	3450	3590	3725	3795	3930	4000		
max 40 km/h FRT				2600	2955	3315	3670	4030	4385	4455	4595	4660	4800		

* Se référer aux remarques en fin des tableaux de cette gamme

MICHELIN AGRIBIB

Caractéristiques & Pression en bar / psi – Charges par pneu en kg*

Ø pouces	Description	CAI	e mm	D mm	R' mm	Cdr mm	Jante(s) recommandée(s)	Jante(s) tolérée(s)	Chambre à air (Code)	Volume interne 75% (litres)	Profond. de sculpture (mm)
42	520/85R42 157A8/1578 TL	122791	539	1945	869	5771	DW18A	DD18 W18A	802	545	59
Bar	0.4	0.5	0.6	0.8	1	1.2	1.4	1.6	1.8		
Psi	6	7	9	12	15	17	20	23	26		
10 km/h	2800	3015	3225	3650	4075	4500	4900	5300	5865		
30 km/h	2000	2180	2360	2800	3175	3550	3965	4375			
40 km/h			2240	2575	2965	3350	3740	4125			
40 km/h Dual	1630	1800	1970	2265	2610	2950	3290	3630			
50 km/h			2240	2575	3000	3350	3740	4125			
max 40 km/h FRT				3090	3555	4020	4485	4950			

Ø pouces	Description	CAI	e mm	D mm	R' mm	Cdr mm	Jante(s) recommandée(s)	Jante(s) tolérée(s)	Chambre à air (Code)	Volume interne 75% (litres)	Profond. de sculpture (mm)				
46	420/80R46 151A8/1488 TL	122770	410	1872	861	5555	DW13	DW12	835	334	51				
Bar	0.4	0.5	0.6	0.8	1	1.2	1.4	1.6	1.8	2	2.1	2.3	2.4	2.6	2.8
Psi	6	7	9	12	15	17	20	23	26	29	30	33	35	38	41
10 km/h	2000	2170	2340	2675	3015	3350	3675	4000	4315	4625	4720	4905	5000	5075	5150
30 km/h	1450	1575	1700	2000	2290	2575	2865	3150	3300	3450	3500	3600	3650		
40 km/h			1600	1850	2140	2430	2665	2900	3075	3250	3300	3400	3450		
40 km/h Dual	1160	1285	1410	1630	1885	2140	2345	2550	2705	2860	2905	2990	3035		
50 km/h			1450	1700	1950	2240	2445	2650	2800	3000	3040	3115	3150		

Ø pouces	Description	CAI	e mm	D mm	R' mm	Cdr mm	Jante(s) recommandée(s)	Jante(s) tolérée(s)	Chambre à air (Code)	Volume interne 75% (litres)	Profond. de sculpture (mm)				
46	480/80R46 158A8/1588 TL	637231	499	1948	889	5874	DW16A	DD16 DW16L W16A	834	449	54				
Bar	0.4	0.5	0.6	0.8	1	1.2	1.4	1.6	1.8	2	2.1	2.3	2.4	2.6	2.8
Psi	6	7	9	12	15	17	20	23	26	29	30	33	35	38	41
10 km/h	2475	2675	2875	3275	3675	4075	4475	4875	5125	5375	5500	5755	5880	6130	6380
30 km/h	1770	1940	2110	2445	2785	3125	3460	3800	3990	4175	4270	4455	4550		
40 km/h			1950	2270	2590	2910	3230	3550	3725	3900	3990	4165	4250		
40 km/h Dual	1450	1585	1715	1940	2165	2390	2615	2840	3065	3290	3405	3630	3740		
50 km/h			1950	2270	2590	2910	3230	3550	3725	3900	3990	4165	4250		
max 40 km/h FRT				2725	3095	3465	3830	4200	4570	4660	4835	4925	5100		

* Se référer aux remarques en fin des tableaux de cette gamme

MICHELIN AGRIBIB

Caractéristiques & Pression en bar / psi – Charges par pneu en kg*

Ø pouces	Description	CAI	e mm	D mm	R' mm	Cdr. mm	Jante(s) recommandée(s)	Jante(s) tolérée(s)	Chambre à air (Code)	Volume interne 75% (litres)	Profond. de sculpture (mm)
46	520/85R46 158A8/155B TL	122780	515	2050	920	6088	DW16A	DW16L W16A DW18L W18L W16L W18A DW18A	834	581	58
Bar	0.4	0.5	0.6	0.8	1	1.2	1.4	1.6	1.8		
Psi	6	7	9	12	15	17	20	23	26		
10 km/h	2900	3115	3325	3750	4175	4600	5025	5450	6070		
30 km/h	2090	2295	2500	2910	3320	3730	4140	4550			
40 km/h			2300	2690	3080	3470	3860	4250			
40 km/h Dual	1715	1885	2055	2390	2730	3065	3400	3740			
50 km/h			2120	2470	2820	3175	3525	3875			
max 40 km/h FRT				3230	3700	4165	4635	5100			

Ø pouces	Description	CAI	e mm	D mm	R' mm	Cdr. mm	Jante(s) recommandée(s)	Jante(s) tolérée(s)	Chambre à air (Code)	Volume interne 75% (litres)	Profond. de sculpture (mm)				
50	480/80R50 159A8/159B TL	471947	474	2056	942	6135	DW15A	DW16A		479	56				
Bar	0.4	0.5	0.6	0.8	1	1.2	1.4	1.6	1.8	2	2.1	2.3	2.4	2.6	2.8
Psi	6	7	9	12	15	17	20	23	26	29	30	33	35	38	41
10 km/h	2575	2785	2995	3415	3830	4250	4700	5150	5575	6000	6075	6225	6300	6400	6500
30 km/h	1800	1990	2180	2575	2915	3250	3625	4000	4190	4375	4440	4565	4625		
40 km/h			2060	2360	2720	3075	3415	3750	3940	4125	4190	4315	4375		
40 km/h Dual	1495	1655	1815	2075	2390	2705	3005	3300	3465	3630	3685	3795	3850		
50 km/h			2060	2360	2725	3075	3415	3750	3875	4125	4190	4315	4375		
max 40 km/h FRT				2830	3230	3635	4035	4440	4840	4910	5045	5115	5250		

Ø pouces	Description	CAI	e mm	D mm	R' mm	Cdr. mm	Jante(s) recommandée(s)	Jante(s) tolérée(s)	Chambre à air (Code)	Volume interne 75% (litres)	Profond. de sculpture (mm)				
50	480/95R50 164A8/164B TL	491183	515	2175	992	6484	DW16B (A)	DW15B (A)		593	53				
Bar	0.4	0.5	0.6	0.8	1	1.2	1.4	1.6	1.8	2	2.1	2.3	2.4	2.6	2.8
Psi	6	7	9	12	15	17	20	23	26	29	30	33	35	38	41
10 km/h	2925	3100	3270	3780	4285	4795	5300	5810	6185	6560	6750	7125	7310	7405	7500
30 km/h	2085	2305	2525	2955	3385	3820	4250	4680	4850	5015	5100	5265	5350		
40 km/h			2360	2765	3165	3570	3970	4375	4530	4690	4765	4920	5000		
40 km/h Dual	1720	1900	2080	2435	2790	3140	3495	3850	3990	4125	4195	4330	4400		
50 km/h			2360	2765	3165	3570	3970	4375	4530	4690	4765	4920	5000		
max 40 km/h FRT				3320	3760	4205	4645	5090	5530	5610	5765	5845	6000		

* Se référer aux remarques en fin des tableaux de cette gamme

MICHELIN AGRIBIB

Caractéristiques & Pression en bar / psi – Charges par pneu en kg*

*REMARQUES

La pression de gonflage se détermine toujours en fonction de la charge par pneu, de la vitesse et du travail à réaliser.

Nos préconisations ci-dessus sont fournies sous réserve de modifications postérieures à la date de diffusion de ces tableaux (mars 2021).

Les données techniques sont susceptibles d'évoluer sans information préalable.

- Pour un usage labour et d'autres usages champ sous couple élevé, utiliser la ligne 30 km/h.
- Lors d'un usage en monte simple :
 - Pour usage en dévers >20% : ajouter 0,4 bar.
 - Pour usage routier intensif >50% : ajouter 0,4 bar.
- FRT (Free Rolling Tire) = Utilisation outil traîné



MICHELIN CEREXBIB 2

**PRODUCTIVITÉ ACCRUE
& MEILLEURE PROTECTION
DES SOLS**



**POUR LES ENGINES DE RÉCOLTE
LES PLUS LOURDS ET LES PLUS PUISSANTS**



CFO+

- Transporter plus de **charge à 10 km/h** en opérations cycliques sur les surfaces agricoles
- **-45% de pression** comparé à un pneu standard ⁽¹⁾



MEILLEURS RENDEMENTS

- **+4% / An** ⁽²⁾



PROTECTION DES SOLS

- Basse pression sur les surfaces agricoles



TRACTION & FLOTATION

(1) Pour une étude à 12 000 kg réalisée avec la dimension 900/60 R32

(2) Harper Adams University 2014/2016

DIMENSIONS

VF 520/80R26 CFO+ 168A8 TL

VF 620/70R26 CFO+ 173A8 TL

VF 750/65R26 CFO+ 180A8 TL

VF 620/70R30 CFO+ 175A8 TL

VF 520/85R30 CFO+ 172A8 TL

VF 710/65R30 CFO+ 179A8 TL

IF 800/65R32 CFO+ 181A8 TL

VF 900/60R32 CFO+ 191A8 TL

IF 800/70R32 CFO+ 185A8 TL

VF 500/85R34 CFO+ 172A8 TL

IF 680/80R38 CFO+ 182A8 TL

VF 900/60R38 CFO+ 193A8 TL

IF 800/70R38 CFO+ 187A8 TL

VF 520/85R42 CFO+ 177A8 TL

VF 580/85R42 CFO+ 183A8 TL

VF 710/70R42 CFO+ 188A8 TL

VF 900/60R42 CFO+ 195A8 TL

IF 800/70R42 CFO+ 189A8 TL

MICHELIN CEREXBIB 2

Caractéristiques & Pression en bar / psi – Charges par pneu en kg*

Ø pouces	Description	CAI	e mm	D mm	R' mm	Cdr. mm	Jante(s) recommandée(s)		Jante(s) tolérée(s)	Chambre à air (Code)	Volume interne 75% (litres)	Profond. de sculpture (mm)			
26	VF 520/80R26 CFO+ 168A8 TL	850494	503	1491	649	4400	DW16L		W16L DW18L	716	366	44			
Bar	1.2	1.4	1.6	1.7	1.8	1.9	2	2.1	2.2	2.3	2.4	2.5	2.6	2.7	2.8
Psi	17	20	23	25	26	28	29	30	32	33	35	36	38	39	41
10 km/h Cyc	5230	5805	6375	6510	6645	6775	6910	7045	7175	7310	7440	7600	7760	7915	8075
15 km/h Cyc	4765	5290	5815	5935	6060	6180	6300	6420	6540	6660	6780	6925	7075	7220	7365
40 km/h	3550	3965	4375	4470	4570	4665	4760	4860	4955	5055	5150	5265	5375	5490	5600

Ø pouces	Description	CAI	e mm	D mm	R' mm	Cdr. mm	Jante(s) recommandée(s)		Jante(s) tolérée(s)	Chambre à air (Code)	Volume interne 75% (litres)	Profond. de sculpture (mm)			
26	VF 620/70R26 CFO+ 173A8 TL	228272	606	1513	655	4461	DW20B (A)			716	463	45			
Bar	1.2	1.4	1.6	1.7	1.8	1.9	2	2.1	2.2	2.3	2.4	2.5	2.6	2.7	2.8
Psi	17	20	23	25	26	28	29	30	32	33	35	36	38	39	41
10 km/h Cyc	6035	6740	7440	7605	7770	7935	8100	8265	8430	8590	8755	8945	9140	9330	9520
15 km/h Cyc	5505	6145	6780	6930	7080	7230	7380	7530	7685	7835	7985	8160	8335	8505	8680
40 km/h	4125	4640	5150	5255	5365	5470	5575	5680	5790	5895	6000	6125	6250	6375	6500

Ø pouces	Description	CAI	e mm	D mm	R' mm	Cdr. mm	Jante(s) recommandée(s)		Jante(s) tolérée(s)	Chambre à air (Code)	Volume interne 75% (litres)	Profond. de sculpture (mm)			
26	VF 750/65R26 CFO+ 180A8 TL	132266	748	1623	701	4786	DW25B (A)			833	659	48			
Bar	1.2	1.4	1.6	1.7	1.8	1.9	2	2.1	2.2	2.3	2.4	2.5	2.6	2.7	2.8
Psi	17	20	23	25	26	28	29	30	32	33	35	36	38	39	41
10 km/h Cyc	7440	8225	9010	9225	9435	9650	9860	10075	10285	10500	10710	10965	11220	11475	11730
15 km/h Cyc	6780	7500	8215	8410	8605	8795	8990	9185	9380	9570	9765	10000	10230	10465	10695
40 km/h	5150	5650	6150	6295	6440	6580	6725	6870	7015	7155	7300	7475	7650	7825	8000

Ø pouces	Description	CAI	e mm	D mm	R' mm	Cdr. mm	Jante(s) recommandée(s)		Jante(s) tolérée(s)	Chambre à air (Code)	Volume interne 75% (litres)	Profond. de sculpture (mm)			
30	VF 620/70R30 CFO+ 175A8 TL	049288	608	1615	700	4765	DW20B (A)			737	506	43			
Bar	1.2	1.4	1.6	1.7	1.8	1.9	2	2.1	2.2	2.3	2.4	2.5	2.6	2.7	2.8
Psi	17	20	23	25	26	28	29	30	32	33	35	36	38	39	41
10 km/h Cyc	6375	7120	7865	8040	8215	8390	8565	8740	8915	9090	9265	9500	9735	9965	10200
15 km/h Cyc	5815	6495	7170	7330	7490	7650	7810	7970	8130	8290	8450	8665	8875	9090	9300
40 km/h	4500	4975	5450	5555	5665	5770	5875	5980	6090	6195	6300	6450	6600	6750	6900

* Se référer aux remarques en fin des tableaux de cette gamme

MICHELIN CEREXBIB 2

Caractéristiques & Pression en bar / psi – Charges par pneu en kg*

Ø pouces	Description	CAI	e mm	D mm	R' mm	Cdr mm	Jante(s) recommandée(s)	Jante(s) tolérée(s)	Chambre à air (Code)	Volume interne 75% (litres)	Profond. de sculpture (mm)				
30	VF 520/85R30 CFO+ 172A8 TL	188276	522	1624	709	4797	W16L		737	435	46				
Bar	1.2	1.4	1.6	1.7	1.8	1.9	2	2.1	2.2	2.3	2.4	2.5	2.6	2.7	2.8
Psi	17	20	23	25	26	28	29	30	32	33	35	36	38	39	41
10 km/h Cyc	5865	6545	7225	7360	7495	7625	7760	7895	8025	8160	8290	8535	8780	9020	9265
15 km/h Cyc	5350	5970	6590	6710	6830	6950	7070	7190	7315	7435	7555	7780	8005	8225	8450
40 km/h	4000	4440	4875	4990	5110	5225	5340	5455	5570	5685	5800	5925	6050	6175	6300

Ø pouces	Description	CAI	e mm	D mm	R' mm	Cdr mm	Jante(s) recommandée(s)	Jante(s) tolérée(s)	Chambre à air (Code)	Volume interne 75% (litres)	Profond. de sculpture (mm)				
30	VF 710/65R30 CFO+ 179A8 TL	608814	694	1676	735	4952	DW25B (A)	DW23B (A)		630	46				
Bar	1.2	1.4	1.6	1.7	1.8	1.9	2	2.1	2.2	2.3	2.4	2.5	2.6	2.7	2.8
Psi	17	20	23	25	26	28	29	30	32	33	35	36	38	39	41
10 km/h Cyc	7225	7990	8755	8970	9180	9395	9605	9820	10030	10245	10455	10690	10925	11155	11390
15 km/h Cyc	6590	7290	7985	8180	8375	8565	8760	8955	9150	9340	9535	9750	9960	10175	10385
40 km/h	5000	5500	6000	6140	6275	6415	6550	6690	6825	6965	7100	7265	7425	7590	7750

Ø pouces	Description	CAI	e mm	D mm	R' mm	Cdr mm	Jante(s) recommandée(s)	Jante(s) tolérée(s)	Chambre à air (Code)	Volume interne 75% (litres)	Profond. de sculpture (mm)				
32	IF 800/65R32 CFO+ 181A8 TL	987406	772	1855	826	5501	DW27B (A)		831	903	57				
Bar	1.2	1.4	1.6	1.7	1.8	1.9	2	2.1	2.2	2.3	2.4	2.5	2.6	2.7	2.8
Psi	17	20	23	25	26	28	29	30	32	33	35	36	38	39	41
10 km/h Cyc	9010	9860	10710	10965	11220	11475	11730	11985	12240	12495	12750	13070	13390	13705	14025
15 km/h Cyc	8215	8990	9765	10000	10230	10465	10695	10930	11160	11395	11625	11915	12210	12500	12790
40 km/h	5300	5800	6300	6450	6600	6750	6900	7050	7200	7350	7500	7690	7875	8065	8250

Ø pouces	Description	CAI	e mm	D mm	R' mm	Cdr mm	Jante(s) recommandée(s)	Jante(s) tolérée(s)	Chambre à air (Code)	Volume interne 75% (litres)	Profond. de sculpture (mm)				
32	VF 900/60R32 CFO+ 191A8 TL	430737	893	1903	827	5618	DW30B (A)	DW27B (A) (NRO)		1033	58				
Bar	1.2	1.4	1.6	1.7	1.8	1.9	2	2.1	2.2	2.3	2.4	2.5	2.6	2.7	2.8
Psi	17	20	23	25	26	28	29	30	32	33	35	36	38	39	41
10 km/h Cyc	9860	10965	12070	12370	12665	12965	13260	13560	13855	14155	14450	14770	15090	15405	15725
15 km/h Cyc	8990	10000	11005	11275	11550	11820	12090	12360	12635	12905	13175	13465	13760	14050	14340
40 km/h	6700	7475	8250	8470	8690	8905	9125	9345	9565	9780	10000	10225	10450	10675	10900

* Se référer aux remarques en fin des tableaux de cette gamme

MICHELIN CEREXBIB 2

Caractéristiques & Pression en bar / psi – Charges par pneu en kg*

Ø pouces	Description	CAI	e mm	D mm	R' mm	Cdr. mm	Jante(s) recommandée(s)	Jante(s) tolérée(s)	Chambre à air (Code)	Volume interne 75% (litres)	Profond. de sculpture (mm)				
32	IF 800/70R32 CFO+ 185A8 TL	789156	796	1950	864	5800	DW27B (A)		831	966	55				
Bar	1.2	1.4	1.6	1.7	1.8	1.9	2	2.1	2.2	2.3	2.4	2.5	2.6	2.7	2.8
Psi	17	20	23	25	26	28	29	30	32	33	35	36	38	39	41
10 km/h Cyc	9860	10965	12070	12370	12665	12965	13260	13560	13855	14155	14450	14770	15090	15405	15725
15 km/h Cyc	8990	10000	11005	11275	11550	11820	12090	12360	12635	12905	13175	13465	13760	14050	14340
40 km/h	5800	6450	7100	7275	7450	7625	7800	7975	8150	8325	8500	8690	8875	9065	9250

Ø pouces	Description	CAI	e mm	D mm	R' mm	Cdr. mm	Jante(s) recommandée(s)	Jante(s) tolérée(s)	Chambre à air (Code)	Volume interne 75% (litres)	Profond. de sculpture (mm)				
34	VF 500/85R34 CFO+ 172A8 TL	038009	497	1676	741	4961	DW16L	DW18L		431	46				
Bar	1.2	1.4	1.6	1.7	1.8	1.9	2	2.1	2.2	2.3	2.4	2.5	2.6	2.7	2.8
Psi	17	20	23	25	26	28	29	30	32	33	35	36	38	39	41
10 km/h Cyc	5870	6445	7020	7180	7340	7495	7655	7815	7975	8130	8290	8470	8650	8830	9010
15 km/h Cyc	5350	5875	6400	6545	6690	6835	6980	7125	7270	7415	7560	7725	7890	8055	8220
40 km/h	4000	4440	4875	4965	5060	5150	5240	5330	5420	5510	5600	5775	5950	6125	6300

Ø pouces	Description	CAI	e mm	D mm	R' mm	Cdr. mm	Jante(s) recommandée(s)	Jante(s) tolérée(s)	Chambre à air (Code)	Volume interne 75% (litres)	Profond. de sculpture (mm)				
38	IF 680/80R38 CFO+ 182A8 TL	953912	646	2020	904	6030	DW21B	DW23B (A)	804	877	59				
Bar	1.2	1.4	1.6	1.7	1.8	1.9	2	2.1	2.2	2.3	2.4	2.5	2.6	2.7	2.8
Psi	17	20	23	25	26	28	29	30	32	33	35	36	38	39	41
10 km/h Cyc	9265	10330	11390	11615	11835	12060	12285	12505	12730	12950	13175	13495	13815	14130	14450
15 km/h Cyc	8450	9420	10385	10590	10795	10995	11200	11405	11610	11810	12015	12305	12595	12885	13175
30 km/h Cyc	7085	7900	8710	8880	9050	9220	9395	9565	9735	9905	10075	10320	10565	10805	11050
40 km/h	5450	6075	6700	6830	6965	7095	7225	7355	7490	7620	7750	7940	8125	8315	8500

Ø pouces	Description	CAI	e mm	D mm	R' mm	Cdr. mm	Jante(s) recommandée(s)	Jante(s) tolérée(s)	Chambre à air (Code)	Volume interne 75% (litres)	Profond. de sculpture (mm)				
38	VF 900/60R38 CFO+ 193A8 TL	439024	879	2029	889	5993	DW30B (A)	DW27B (A) (NRO)		1149	58				
Bar	1.2	1.4	1.6	1.7	1.8	1.9	2	2.1	2.2	2.3	2.4	2.5	2.6	2.7	2.8
Psi	17	20	23	25	26	28	29	30	32	33	35	36	38	39	41
10 km/h Cyc	10455	11605	12750	13070	13390	13705	14025	14345	14665	14980	15300	15725	16150	16575	17000
15 km/h Cyc	9765	10885	12000	12245	12490	12730	12975	13220	13465	13705	13950	14350	14750	15150	15550
40 km/h	7300	8025	8750	8980	9215	9445	9675	9905	10140	10370	10600	10825	11050	11275	11500

* Se référer aux remarques en fin des tableaux de cette gamme

MICHELIN CEREXBIB 2

Caractéristiques & Pression en bar / psi – Charges par pneu en kg*

Ø pouces	Description	CAI	e mm	D mm	R' mm	Cdr mm	Jante(s) recommandée(s)	Jante(s) tolérée(s)	Chambre à air (Code)	Volume interne 75% (litres)	Profond. de sculpture (mm)				
38	IF 800/70R38 CFO+ 187A8 TL	610997	790	2051	912	6079	DW27B (A)		804	1088	57				
Bar	1.2	1.4	1.6	1.7	1.8	1.9	2	2.1	2.2	2.3	2.4	2.5	2.6	2.7	2.8
Psi	17	20	23	25	26	28	29	30	32	33	35	36	38	39	41
10 km/h Cyc	10710	11945	13175	13440	13705	13970	14240	14505	14770	15035	15300	15620	15940	16255	16575
15 km/h Cyc	9765	10885	12000	12245	12490	12730	12975	13220	13465	13705	13950	14240	14530	14820	15110
40 km/h	6300	7025	7750	7905	8065	8220	8375	8530	8690	8845	9000	9190	9375	9565	9750

Ø pouces	Description	CAI	e mm	D mm	R' mm	Cdr mm	Jante(s) recommandée(s)	Jante(s) tolérée(s)	Chambre à air (Code)	Volume interne 75% (litres)	Profond. de sculpture (mm)				
42	VF 520/85R42 CFO+ 177A8 TL	270459	541	1953	881	5807	DW18B(A)	DD18 W18L	802	545	55				
Bar	1.2	1.4	1.6	1.7	1.8	1.9	2	2.1	2.2	2.3	2.4	2.5	2.6	2.7	2.8
Psi	17	20	23	25	26	28	29	30	32	33	35	36	38	39	41
10 km/h Cyc	6800	7545	8285	8465	8650	8830	9010	9225	9435	9650	9860	10075	10285	10500	10710
10 km/h Cyc Dual	5985	6640	7295	7470	7640	7815	7985	8160	8330	8505	8675	8865	9050	9240	9425
15 km/h Cyc	6200	6880	7555	7720	7885	8050	8215	8410	8605	8795	8990	9185	9380	9570	9765
15 km/h Cyc Dual	5455	6055	6650	6810	6965	7125	7280	7440	7595	7755	7910	8080	8255	8425	8595
40 km/h	4625	5215	5800	5915	6025	6140	6250	6365	6475	6590	6700	6850	7000	7150	7300

Ø pouces	Description	CAI	e mm	D mm	R' mm	Cdr mm	Jante(s) recommandée(s)	Jante(s) tolérée(s)	Chambre à air (Code)	Volume interne 75% (litres)	Profond. de sculpture (mm)				
42	VF 580/85R42 CFO+ 183A8 TL	844076	580	2040	903	6040	DW18B(A)		802	701	58				
Bar	1.2	1.4	1.6	1.7	1.8	1.9	2	2.1	2.2	2.3	2.4	2.5	2.6	2.7	2.8
Psi	17	20	23	25	26	28	29	30	32	33	35	36	38	39	41
10 km/h Cyc	8075	8970	9860	10050	10245	10435	10625	10815	11010	11200	11390	11730	12070	12410	12750
10 km/h Cyc Dual	7110	7895	8680	8850	9015	9185	9350	9520	9685	9855	10020	10320	10620	10920	11220
15 km/h Cyc	7365	8180	8990	9165	9340	9515	9690	9860	10035	10210	10385	10695	11005	11315	11625
15 km/h Cyc Dual	6480	7195	7910	8065	8220	8370	8525	8680	8835	8985	9140	9415	9685	9960	10230
40 km/h	5450	6075	6700	6865	7025	7190	7350	7515	7675	7840	8000	8190	8375	8565	8750

Ø pouces	Description	CAI	e mm	D mm	R' mm	Cdr mm	Jante(s) recommandée(s)	Jante(s) tolérée(s)	Chambre à air (Code)	Volume interne 75% (litres)	Profond. de sculpture (mm)				
42	VF 710/70R42 CFO+ 188A8 TL	499992	705	2097	927	6207	DW23B (A)	DW25B (A)	802	867	64				
Bar	1.2	1.4	1.6	1.7	1.8	1.9	2	2.1	2.2	2.3	2.4	2.5	2.6	2.7	2.8
Psi	17	20	23	25	26	28	29	30	32	33	35	36	38	39	41
10 km/h Cyc	9265	10330	11390	11615	11835	12060	12280	12505	12730	12950	13175	13495	13815	14130	14450
15 km/h Cyc	8450	9420	10385	10590	10795	10995	11200	11405	11610	11810	12015	12305	12595	12885	13175
40 km/h			7750	7905	8065	8220	8375	8530	8690	8845	9000	9250	9500	9750	10000

* Se référer aux remarques en fin des tableaux de cette gamme

MICHELIN CEREXBIB 2

Caractéristiques & Pression en bar / psi – Charges par pneu en kg*

Ø pouces	Description	CAI	e mm	D mm	R' mm	Cdr. mm	Jante(s) recommandée(s)		Jante(s) tolérée(s)		Chambre à air (Code)	Volume interne 75% (litres)		Profond. de sculpture (mm)	
42	VF 900/60R42 CFO+ 195A8 TL	856296	843	2118	930	6281	DW30B (A)		TW30B			1227	59		
Bar	1.2	1.4	1.6	1.7	1.8	1.9	2	2.1	2.2	2.3	2.4	2.5	2.6	2.7	2.8
Psi	17	20	23	25	26	28	29	30	32	33	35	36	38	39	41
10 km/h Cyc	11050	12325	13600	13920	14240	14555	14875	15195	15515	15830	16150	16490	16830	17170	17510
15 km/h Cyc	10075	11240	12400	12690	12985	13275	13565	13855	14145	14435	14725	15035	15345	15655	15965
30 km/h Cyc	8450	9425	10400	10645	10890	11130	11375	11620	11865	12105	12350	12610	12870	13130	13390
40 km/h	7500	8375	9250	9515	9775	10040	10300	10525	10750	10975	11200	11440	11675	11915	12150

Ø pouces	Description	CAI	e mm	D mm	R' mm	Cdr. mm	Jante(s) recommandée(s)		Jante(s) tolérée(s)		Chambre à air (Code)	Volume interne 75% (litres)		Profond. de sculpture (mm)	
42	IF 800/70R42 CFO+ 189A8 TL	818789	770	2151	964	6387	DW27B (A)		DW25B (A) DW28B (A)			1145	58		
Bar	1.2	1.4	1.6	1.7	1.8	1.9	2	2.1	2.2	2.3	2.4	2.5	2.6	2.7	2.8
Psi	17	20	23	25	26	28	29	30	32	33	35	36	38	39	41
10 km/h Cyc	11050	12325	13600	13920	14240	14555	14875	15195	15515	15830	16150	16490	16830	17170	17510
15 km/h Cyc	10075	11240	12400	12690	12980	13270	13565	13855	14145	14435	14725	15035	15345	15655	15965
30 km/h Cyc	8450	9425	10400	10645	10890	11130	11375	11620	11865	12105	12350	12610	12870	13130	13390
40 km/h	6500	7250	8000	8190	8375	8565	8750	8940	9125	9315	9500	9700	9900	10100	10300

*REMARQUES

La pression de gonflage se détermine toujours en fonction de la charge par pneu, de la vitesse et du travail à réaliser.

Nos préconisations ci-dessus sont fournies sous réserve de modifications postérieures à la date de diffusion de ces tableaux (mars 2021).

Les données techniques sont susceptibles d'évoluer sans information préalable.

- Pour les machines standard ou à correction de dévers travaillant sur des pentes >20% (11°), ajouter 0,5 bar sans dépasser la pression maximale
- Pour usage routier intensif >50% : ajouter 0,4 bar.
- 10 km/h Cyc: Travaux de récolte avec charge cyclique, utilisation champ uniquement
- 15 km/h Cyc: Travaux de récolte avec charge cyclique, utilisation champ uniquement
- CFO+: Cyclic Field Operation autorisant un bonus pour charge cyclique au champ sur une distance de 1,5km maximum



MICHELIN CEREXBIB

CAPACITÉ DE CHARGE ÉLEVÉE À BASSE PRESSION POUR ENGIN DE RÉCOLTE



POUR DES ENGIN DE RÉCOLTE LOURDS ET PUISSANTS



MEILLEURS RENDEMENTS

- +4% / An⁽¹⁾



Meilleure **CAPACITÉ DE CHARGE** jusqu'à 40 %⁽²⁾



MEILLEURE TRACTION

- Adhérence améliorée en pente
- Capacité à travailler sur sol gras



PLUS FAIBLE PRESSION DE GONFLAGE

- -35%⁽¹⁾ jusqu'à -1 bar de pression⁽³⁾



EMPREINTE PLUS ÉTENDUE

- +25%⁽¹⁾ de surface de contact

(1) Harper Adams University 2014/2016

(2) Test interne 2013-2015

(3) SI 1000/55 R32 CFO MICHELIN CERXBIB vs 1050/50 R32 MICHELIN MEGAXBIB

DIMENSIONS

VF 520/80R26 CFO 168A8 TL

VF 620/70R26 CFO 173A8 TL

VF 750/65R26 CFO 177A8 TL

VF 620/70R30 CFO 172A8 TL

VF 520/85R30 CFO 172A8 TL

IF 800/65R32 CFO 178A8/178B TL

IF 900/60R32 CFO 185A8 TL

IF 1000/55R32 CFO 188A8 TL

IF 680/85R32 CFO 179A8/179B TL

IF 800/70R32 CFO 182A8/182B TL

IF 680/75R38 180A8 TL

IF 900/60R38 CFO 188A8 TL

IF 900/60R38 CFO 184A8 TL

IF 800/70R38 CFO 184A8/184B TL

IF 800/70R38 CFO 187A8 TL

VF 520/85R42 CFO 177A8 TL

IF 710/70R42 CFO 182A8 TL

MICHELIN CEREXBIB

Caractéristiques & Pression en bar / psi – Charges par pneu en kg*

Ø pouces	Description	CAI	e mm	D mm	R' mm	Cdr mm	Jante(s) recommandée(s)	Jante(s) tolérée(s)	Chambre à air (Code)	Volume interne 75% (litres)	Profond. de sculpture (mm)
26	VF 520/80R26 CFO 168A8 TL	972024	503	1491	649	4397	DW16L	W16L DW18L	716	366	44
Bar	1.2 1.4 1.6 1.7 1.8 1.9 2 2.1 2.2 2.3 2.4 2.5 2.6 2.7 2.8										
Psi	17 20 23 25 26 28 29 30 32 33 35 36 38 39 41										
15 km/h Cyc	4720 5270 5820 5950 6080 6205 6335 6465 6595 6720 6850 7000 7150 7300 7450										
40 km/h	3550 3965 4375 4470 4570 4665 4765 4860 4955 5055 5150 5265 5375 5490 5600										

Ø pouces	Description	CAI	e mm	D mm	R' mm	Cdr mm	Jante(s) recommandée(s)	Jante(s) tolérée(s)	Chambre à air (Code)	Volume interne 75% (litres)	Profond. de sculpture (mm)
26	VF 620/70R26 CFO 173A8 TL	656967	606	1513	655	4458	DW20B (A)		716	463	45
Bar	1.2 1.4 1.6 1.7 1.8 1.9 2 2.1 2.2 2.3 2.4 2.5 2.6 2.7 2.8										
Psi	17 20 23 25 26 28 29 30 32 33 35 36 38 39 41										
15 km/h Cyc	5485 6170 6850 6990 7135 7275 7415 7555 7700 7840 7980 8150 8315 8485 8650										
40 km/h	4125 4640 5150 5255 5365 5470 5575 5680 5790 5895 6000 6125 6250 6375 6500										

Ø pouces	Description	CAI	e mm	D mm	R' mm	Cdr mm	Jante(s) recommandée(s)	Jante(s) tolérée(s)	Chambre à air (Code)	Volume interne 75% (litres)	Profond. de sculpture (mm)
26	VF 750/65R26 CFO 177A8 TL	811382	743	1623	701	4780	DW25B (A)		833	659	48
Bar	1.2 1.4 1.6 1.7 1.8 1.9 2 2.1 2.2 2.3 2.4										
Psi	17 20 23 25 26 28 29 30 32 33 35										
15 km/h Cyc	6850 7515 8180 8370 8565 8755 8945 9135 9330 9520 9710										
40 km/h	5150 5650 6150 6295 6440 6580 6725 6870 7015 7155 7300										

Ø pouces	Description	CAI	e mm	D mm	R' mm	Cdr mm	Jante(s) recommandée(s)	Jante(s) tolérée(s)	Chambre à air (Code)	Volume interne 75% (litres)	Profond. de sculpture (mm)
30	VF 620/70R30 CFO 172A8 TL	886789	598	1615	700	4760	DW20B (A)		737	506	43
Bar	1.2 1.4 1.6 1.7 1.8 1.9 2 2.1 2.2 2.3 2.4										
Psi	17 20 23 25 26 28 29 30 32 33 35										
15 km/h Cyc	5985 6620 7250 7390 7535 7675 7815 7955 8100 8240 8380										
40 km/h	4500 4975 5450 5555 5665 5770 5875 5980 6090 6195 6300										

Ø pouces	Description	CAI	e mm	D mm	R' mm	Cdr mm	Jante(s) recommandée(s)	Jante(s) tolérée(s)	Chambre à air (Code)	Volume interne 75% (litres)	Profond. de sculpture (mm)
30	VF 520/85R30 CFO 172A8 TL	795916	522	1624	709	4794	W16L		737	435	46
Bar	1.2 1.4 1.6 1.7 1.8 1.9 2 2.1 2.2 2.3 2.4 2.5 2.6 2.7 2.8										
Psi	17 20 23 25 26 28 29 30 32 33 35 36 38 39 41										
15 km/h Cyc	5320 5905 6485 6640 6795 6945 7100 7255 7410 7560 7715 7880 8050 8215 8380										
40 km/h	4000 4440 4875 4990 5105 5220 5340 5455 5570 5685 5800 5925 6050 6175 6300										

* Se référer aux remarques en fin des tableaux de cette gamme

MICHELIN CEREXBIB

Caractéristiques & Pression en bar / psi – Charges par pneu en kg*

Ø pouces	Description	CAI	e mm	D mm	R' mm	Cdr mm	Jante(s) recommandée(s)	Jante(s) tolérée(s)	Chambre à air (Code)	Volume interne 75% (litres)	Profond. de sculpture (mm)
32	IF 800/65R32 CFO 178A8/178B TL	651074	768	1855	818	5493	DW27B (A)	DW30B (A)	831	903	57
Bar	1.2 1.4 1.6 1.7 1.8 1.9 2 2.1 2.2 2.3 2.4										
Psi	17 20 23 25 26 28 29 30 32 33 35										
15 km/h Cyc	8215 8990 9765 10000 10230 10465 10695 10930 11160 11395 11625										
40 km/h	5300 5800 6300 6450 6600 6750 6900 7050 7200 7350 7500										

Ø pouces	Description	CAI	e mm	D mm	R' mm	Cdr mm	Jante(s) recommandée(s)	Jante(s) tolérée(s)	Chambre à air (Code)	Volume interne 75% (litres)	Profond. de sculpture (mm)
32	IF 900/60R32 CFO 185A8 TL	752825	856	1906	844	5643	DW27B (A)	DW30B (A)	831	1033	58
Bar	1.2 1.4 1.6 1.7 1.8 1.9 2 2.1 2.2 2.3 2.4 2.5 2.6 2.7 2.8										
Psi	17 20 23 25 26 28 29 30 32 33 35 36 38 39 41										
15 km/h Cyc	8990 9995 11000 11270 11545 11815 12090 12360 12630 12905 13175 13465 13760 14050 14340										
40 km/h	5800 6450 7100 7275 7450 7625 7800 7975 8150 8325 8500 8690 8875 9065 9250										

Ø pouces	Description	CAI	e mm	D mm	R' mm	Cdr mm	Jante(s) recommandée(s)	Jante(s) tolérée(s)	Chambre à air (Code)	Volume interne 75% (litres)	Profond. de sculpture (mm)
32	IF 1000/55R32 CFO 188A8 TL	131720	1040	1931	882	5758	36.00VA			1178	59
Bar	1.2 1.4 1.6 1.7 1.8 1.9 2 2.1 2.2 2.3 2.4 2.5 2.6 2.7 2.8										
Psi	17 20 23 25 26 28 29 30 32 33 35 36 38 39 41										
15 km/h Cyc	9765 10890 12015 12305 12595 12885 13180 13470 13760 14050 14340 14630 14920 15210 15500										
40 km/h	6300 7025 7750 7940 8125 8315 8500 8690 8875 9065 9250 9440 9625 9815 10000										

Ø pouces	Description	CAI	e mm	D mm	R' mm	Cdr mm	Jante(s) recommandée(s)	Jante(s) tolérée(s)	Chambre à air (Code)	Volume interne 75% (litres)	Profond. de sculpture (mm)
32	IF 680/85R32 CFO 179A8/179B TL	932041	682	1935	844	5711	DW23B (A)	DW21B (A)	831	859	46
Bar	1.2 1.4 1.6 1.7 1.8 1.9 2 2.1 2.2 2.3 2.4										
Psi	17 20 23 25 26 28 29 30 32 33 35										
15 km/h Cyc	8450 9420 10385 10590 10795 10995 11200 11405 11610 11810 12015										
40 km/h	5450 6075 6700 6830 6965 7095 7225 7355 7490 7620 7750										

Ø pouces	Description	CAI	e mm	D mm	R' mm	Cdr mm	Jante(s) recommandée(s)	Jante(s) tolérée(s)	Chambre à air (Code)	Volume interne 75% (litres)	Profond. de sculpture (mm)
32	IF 800/70R32 CFO 182A8/182B TL	525718	784	1958	864	5788	DW27B (A)		831	966	55
Bar	1.2 1.4 1.6 1.7 1.8 1.9 2 2.1 2.2 2.3 2.4										
Psi	17 20 23 25 26 28 29 30 32 33 35										
15 km/h Cyc	8990 10000 11005 11275 11550 11820 12090 12360 12635 12905 13175										
40 km/h	5800 6450 7100 7275 7450 7625 7800 7975 8150 8325 8500										

* Se référer aux remarques en fin des tableaux de cette gamme

MICHELIN CEREXBIB

Caractéristiques & Pression en bar / psi – Charges par pneu en kg*

Ø pouces	Description	CAI	e mm	D mm	R' mm	Cdr mm	Jante(s) recommandée(s)	Jante(s) tolérée(s)	Chambre à air (Code)	Volume interne 75% (litres)	Profond. de sculpture (mm)				
38	IF 680/75R38 180A8 TL	833220	663	1965	874	5823	DW23B (A)	DW21B (A)	804	803	59				
Bar	1.2	1.4	1.6	1.7	1.8	1.9	2	2.1	2.2	2.3	2.4	2.5	2.6	2.7	2.8
Psi	17	20	23	25	26	28	29	30	32	33	35	36	38	39	41
15 km/h Cyc	7980	8875	9765	10000	10230	10465	10695	10930	11160	11395	11625	11820	12015	12205	12400
15 km/h Cyc > pente 20%				7980	8425	8875	9320	9765	10000	10230	10465	10695	10930	11160	11395
40 km/h	5150	5725	6300	6450	6600	6750	6900	7050	7200	7350	7500	7625	7750	7875	8000

Ø pouces	Description	CAI	e mm	D mm	R' mm	Cdr mm	Jante(s) recommandée(s)	Jante(s) tolérée(s)	Chambre à air (Code)	Volume interne 75% (litres)	Profond. de sculpture (mm)				
38	IF 900/60R38 CFO 188A8 TL	853436	879	2029	902	6017	DW30B (A)			1149	58				
Bar	1.2	1.4	1.6	1.7	1.8	1.9	2	2.1	2.2	2.3	2.4	2.5	2.6	2.7	2.8
Psi	17	20	23	25	26	28	29	30	32	33	35	36	38	39	41
15 km/h Cyc	9765	10885	12000	12245	12490	12730	12975	13220	13465	13705	13950	14350	14750	15150	15550
40 km/h	6300	7025	7750	7905	8065	8220	8375	8530	8690	8845	9000	9250	9500	9750	10000

Ø pouces	Description	CAI	e mm	D mm	R' mm	Cdr mm	Jante(s) recommandée(s)	Jante(s) tolérée(s)	Chambre à air (Code)	Volume interne 75% (litres)	Profond. de sculpture (mm)
38	IF 900/60R38 CFO 184A8 TL	296920	874	2033	904	6017	DW30B (A)			1149	58
Bar	1.2	1.4	1.6	1.7	1.8	1.9	2	2.1	2.2	2.3	2.4
Psi	17	20	23	25	26	28	29	30	32	33	35
15 km/h Cyc	9765	10885	12000	12245	12490	12730	12975	13220	13465	13705	13950
40 km/h	6300	7025	7750	7905	8065	8220	8375	8530	8690	8845	9000

Ø pouces	Description	CAI	e mm	D mm	R' mm	Cdr mm	Jante(s) recommandée(s)	Jante(s) tolérée(s)	Chambre à air (Code)	Volume interne 75% (litres)	Profond. de sculpture (mm)
38	IF 800/70R38 CFO 184A8/184B TL	646846	781	2048	908	6072	DW27B (A)		804	1088	57
Bar	1.2	1.4	1.6	1.7	1.8	1.9	2	2.1	2.2	2.3	2.4
Psi	17	20	23	25	26	28	29	30	32	33	35
15 km/h Cyc	9765	10885	12000	12245	12490	12730	12975	13220	13465	13705	13950
40 km/h	6300	7025	7750	7905	8065	8220	8375	8530	8690	8845	9000

* Se référer aux remarques en fin des tableaux de cette gamme

MICHELIN CEREXBIB

Caractéristiques & Pression en bar / psi – Charges par pneu en kg*

Ø pouces	Description	CAI	e mm	D mm	R' mm	Cdr mm	Jante(s) recommandée(s)	Jante(s) tolérée(s)	Chambre à air (Code)	Volume interne 75% (litres)	Profond. de sculpture (mm)				
38	IF 800/70R38 CFO 187A8 TL	445898	790	2051	912	6079	DW27B (A)		804	1088	57				
Bar	1.2 1.4 1.6 1.7 1.8 1.9 2	2.1 2.2 2.3 2.4 2.5	2.6 2.7 2.8 2.9 3.0 3.1 3.2	3.3 3.4 3.5	3.6 3.7 3.8 3.9 4.0	4.1									
Psi	17 20 23 25 26 28 29	30 32 33 35 36 38 39	41												
15 km/h Cyc	9765	10885	12000	12245	12490	12730	12975	13220	13465	13705	13950	14240	14530	14820	15110
40 km/h	6300	7025	7750	7905	8065	8220	8375	8530	8690	8845	9000	9190	9375	9565	9750

Ø pouces	Description	CAI	e mm	D mm	R' mm	Cdr mm	Jante(s) recommandée(s)	Jante(s) tolérée(s)	Chambre à air (Code)	Volume interne 75% (litres)	Profond. de sculpture (mm)				
42	VF 520/85R42 CFO 177A8 TL	934265	541	1953	881	5807	DW188(A)	DD18 DW18L	802	545	55				
Bar	1.2 1.4 1.6 1.7 1.8 1.9 2	2.1 2.2 2.3 2.4 2.5	2.6 2.7 2.8 2.9 3.0 3.1 3.2	3.3 3.4 3.5	3.6 3.7 3.8 3.9 4.0	4.1									
Psi	17 20 23 25 26 28 29	30 32 33 35 36 38 39	41												
15 km/h Cyc Dual	5455	5865	6275	6480	6685	6885	7090	7295	7500	7705	7910	8080	8255	8425	8595
40 km/h	4625	4970	5315	5490	5665	5835	6010	6180	6355	6525	6700	6850	7000	7150	7300

Ø pouces	Description	CAI	e mm	D mm	R' mm	Cdr mm	Jante(s) recommandée(s)	Jante(s) tolérée(s)	Chambre à air (Code)	Volume interne 75% (litres)	Profond. de sculpture (mm)			
42	IF 710/70R42 CFO 182A8 TL	003912	705	2097	942	6230	DW23B (A)		802	872	64			
Bar	1.4 1.6 1.7 1.8 1.9 2 2.1 2.2 2.3 2.4 2.5	2.6 2.7 2.8 2.9 3.0 3.1 3.2 3.3 3.4 3.5	3.6 3.7 3.8 3.9 4.0	4.1										
Psi	20 23 25 26 28 29 30 32 33 35 36	38 39 41												
15 km/h Cyc	9300	10385	10590	10790	10995	11200	11400	11605	11805	12010	12300	12595	12885	13175
40 km/h	6000	6700	6830	6965	7095	7225	7355	7490	7620	7750	7940	8125	8315	8500

*REMARQUES

La pression de gonflage se détermine toujours en fonction de la charge par pneu, de la vitesse et du travail à réaliser.

Nos préconisations ci-dessus sont fournies sous réserve de modifications postérieures à la date de diffusion de ces tableaux (mars 2021).

Les données techniques sont susceptibles d'évoluer sans information préalable.

Les pneus CEREXBIB portant le marquage CFO ont été développés pour être en conformité avec la norme expérimentale ETRTO, mise en place en 2014 pour une durée de 4 ans, avant l'adoption possible d'un nouveau standard. Les pneus qui adoptent cette nouvelle norme expérimentale doivent porter les lettres CFO comme suffixe et acceptent l'augmentation de charge indiquée dans le tableau ci-dessus. Les pneus ne portant pas ce marquage spécifique ne peuvent pas supporter une augmentation de la charge en conditions de charge cycliques.

- Pour les machines standard ou à correction de dévers travaillant sur des pentes >20% (11°), ajouter 0,5 bar sans dépasser la pression maximale
- Pour usage routier intensif >50% : ajouter 0,4 bar.
- 15 km/h Cyc: Travaux de récolte avec charge cyclique, utilisation champ uniquement
- CFO: Cyclic Field Operation autorisant un bonus pour charge cyclique au champ sur une distance de 1,5km maximum



MICHELIN FLOATXBIB

LA CAPACITÉ DE CHARGE
AU CHAMP **LA PLUS ÉLEVÉE**
POUR VOS TRAVAUX D'ÉPANDAGE
ET LE **MEILLEUR INDICE**
DE VITESSE DU MARCHÉ



POUR ÉPANDEURS AUTOMOTEURS



PRODUCTIVITÉ AUGMENTÉE

- Meilleure répartition de la pression
- Meilleure résistance aux chaumes et à l'usure
- Nouvelle architecture et nouvelle carcasse présentant les avantages de la technologie MICHELIN ULTRAFLEX : basse pression & haute capacité de charge/indice de vitesse élevé
- 1^{er} pneu VF CFO index E pour un usage en flottaison (CFO permet d'augmenter la charge de 55% à une vitesse de 15 km/h max)



MEILLEURS RENDEMENTS

- Épaules arrondies permettant une meilleure protection de la couche de végétation
- Barrettes des épaules doublées et renforcées pour améliorer la surface de contact



CONFORT ACCRU ET VITESSE PLUS ÉLEVÉE

- Zone centrale renforcée avec un design spécial des barrettes (Dépôt brevet)

SIZES

VF 1000/50R25 CFO 190D/186E TL **NEW**

VF 750/50R26 CFO 174D/170E TL **NEW**

IF 1000/55R32 CFO 191D/188E TL

VF 1000/55R32 CFO 197D/193E TL **NEW**

VF 900/60R38 CFO 196D/192E TL **NEW**

MICHELIN FLOATXBIB

Caractéristiques & Pression en bar / psi – Charges par pneu en kg*

Ø pouces	Description	CAI	e mm	D mm	R' mm	Cdr. mm	Jante(s) recommandée(s)		Jante(s) tolérée(s)	Chambre à air (Code)	Volume interne 75% (litres)	Profond. de sculpture (mm)
25	VF 1000/50R25 CFO 190D/186E TL NEW	713716	1025	1643	712	4841	36.0TH				893	40
Bar	1.2 1.4 1.6 1.8 2 2.2 2.4 2.6 2.8 3 3.2											
Psi	17 20 23 26 29 32 35 38 41 44 46											
15 km/h Cyc	8215 9145 10075 10540 11005 11510 12015 12595 13175											
30 km/h Cyc	6890 7670 8450 8840 9230 9655 10075 10565 11050 11375 11700											
65 km/h	6150 6825 7500 7875 8250 8625 9000 9375 9750 10175 10600											
70 km/h	5595 6210 6825 7165 7510 7850 8190 8530 8875 9185 9500											

Ø pouces	Description	CAI	e mm	D mm	R' mm	Cdr. mm	Jante(s) recommandée(s)		Jante(s) tolérée(s)	Chambre à air (Code)	Volume interne 75% (litres)	Profond. de sculpture (mm)
26	VF 750/50R26 CFO 174D/170E TL NEW	982905	750	1405	619	4155	DW25B (A)				458	39
Bar	1.2 1.4 1.6 1.8 2 2.2 2.4 2.6 2.8 3 3.2											
Psi	17 20 23 26 29 32 35 38 41 44 46											
15 km/h Cyc	5195 5795 6395 6685 6975 7265 7555 8000 8450 8720 8990											
30 km/h Cyc	4355 4860 5365 5605 5850 6095 6340 6710 7085 7315 7540											
65 km/h	3875 4315 4750 5025 5300 5550 5800 6050 6300 6500 6700											
70 km/h	3525 3925 4325 4575 4825 5050 5280 5505 5735 5865 6000											

Ø pouces	Description	CAI	e mm	D mm	R' mm	Cdr. mm	Jante(s) recommandée(s)		Jante(s) tolérée(s)	Chambre à air (Code)	Volume interne 75% (litres)	Profond. de sculpture (mm)
32	IF 1000/55R32 CFO 191D/188E TL	564739	1042	1877	820	5540	36.00VA				1178	38
Bar	1.2 1.4 1.6 1.8 2 2.2 2.4 2.6 2.8 3 3.2											
Psi	17 20 23 26 29 32 35 38 41 44 46											
15 km/h Cyc	9765 10890 12015 12595 13175 13755 14340 14920 15500 16200 16895											
30 km/h Cyc	8190 9135 10075 10565 11050 11540 12025 12515 13000 13585 14170											
65 km/h	6300 7025 7750 8125 8500 8875 9250 9625 10000 10450 10900											
70 km/h	5800 6450 7100 7425 7750 8125 8500 8875 9250 9625 10000											

Ø pouces	Description	CAI	e mm	D mm	R' mm	Cdr. mm	Jante(s) recommandée(s)		Jante(s) tolérée(s)	Chambre à air (Code)	Volume interne 75% (litres)	Profond. de sculpture (mm)
32	VF 1000/55R32 CFO 197D/193E TL NEW	946690	1042	1877	808	5523	36.00VA				1178	39
Bar	1.2 1.4 1.6 1.8 2 2.2 2.4 2.6 2.8 3 3.2											
Psi	17 20 23 26 29 32 35 38 41 44 46											
15 km/h Cyc	9765 10890 12015 12595 13175 13760 14340 14920 15500 16200 16895											
30 km/h Cyc	8190 9135 10075 10565 11050 11540 12025 12515 13000 13585 14170											
65 km/h	7300 7775 8250 9125 10000 10450 10900 11350 11800 12325 12850											
70 km/h	6650 7075 7500 8300 9100 9500 9900 10325 10750 11225 11700											

* Se référer aux remarques en fin des tableaux de cette gamme

MICHELIN FLOATXBIB

Caractéristiques & Pression en bar / psi – Charges par pneu en kg*

Ø pouces	Description	CAI	e mm	D mm	R' mm	Cdr mm	Jante(s) recommandée(s)		Jante(s) tolérée(s)		Chambre à air (Code)	Volume interne 75% (litres)	Profond. de sculpture (mm)
38	VF 900/60R38 CFO 196D/192E TL NEW	098689	873	2039	914	6041	DW30B (A)		DW27B (A) (NRO)			1149	39
Bar	1.2 1.4 1.6 1.8 2 2.2 2.4 2.6 2.8 3 3.2												
Psi	17 20 23 26 29 32 35 38 41 44 46												
15 km/h Cyc	9535 10580 11625 12400 13175 13565 13950 14725 15500 15965 16430												
30 km/h Cyc	7995 8875 9750 10400 11050 11375 11700 12350 13000 13390 13780												
65 km/h	7300 8025 8750 9250 9750 10175 10600 11050 11500 12000 12500												
70 km/h	6645 7305 7965 8420 8875 9260 9645 10055 10465 10835 11200												

*REMARQUES

La pression de gonflage se détermine toujours en fonction de la charge par pneu, de la vitesse et du travail à réaliser.

Nos préconisations ci-dessus sont fournies sous réserve de modifications postérieures à la date de diffusion de ces tableaux (mars 2021).

Les données techniques sont susceptibles d'évoluer sans information préalable.

Les pneus FLOATXBIB portant le marquage CFO ont été développés pour être en conformité avec la norme expérimentale ETRTO, mise en place en 2014 pour une durée de 4 ans, avant l'adoption possible d'un nouveau standard. Les pneus qui adoptent cette nouvelle norme expérimentale doivent porter les lettres CFO comme suffixe et acceptent l'augmentation de charge indiquée dans le tableau ci-dessus. Les pneus ne portant pas ce marquage spécifique ne peuvent pas supporter une augmentation de la charge en conditions de charge cycliques.

- Pour les machines standard ou à correction de dévers travaillant sur des pentes >20% (11°), ajouter 0,5 bar sans dépasser la pression maximale
- Pour usage routier intensif >50% : ajouter 0,4 bar.
- 15 km/h Cyc: Travaux de récolte avec charge cyclique, utilisation champ uniquement
- CFO: Cyclic Field Operation autorisant un bonus pour charge cyclique au champ sur une distance de 1,5km maximum
- (NRO) - Narrow Rim Option. Ajouter 0,2 bar en cas de montage sur une jante NRO.



MICHELIN MEGAXBIB 2

EXCELLENT RAPPORT
QUALITÉ/PRIX POUR
LES ENGINES DE RÉCOLTE



POUR LES ENGINES DE RÉCOLTE



ROBUSTE ET PLUS RÉSISTANT AUX CHAUMES

- Carcasse renforcée
- Durée de vie plus longue



AVANTAGES DE LA GAMME MEGAXBIB 2

- Excellente maniabilité sur route
- Capacités à forte charge / grande vitesse



MARQUAGE STUBBLE SHIELD

- Protection contre les dommages liés aux chaumes



DIMENSIONS

1000/50R25 172A8/166D TL

750/50R26 160A8/154D TL

650/75R32 172A8/172B TL

800/65R32 178A8/178B TL

1050/50R32 178A8/172D TL

900/60R32 181A8/181B TL

800/70R32 181A8/181B TL **NEW**

710/75R34 178A8/178B TL **NEW**

620/70R38 170A8/170B TL **NEW**

MICHELIN MEGAXBIB 2

Caractéristiques & Pression en bar / psi – Charges par pneu en kg*

Ø pouces	Description	CAI	e mm	D mm	R' mm	Cdr mm	Jante(s) recommandée(s)	Jante(s) tolérée(s)	Chambre à air (Code)	Volume interne 75% (litres)	Profond. de sculpture (mm)
25	1000/50R25 172A8/166D TL <i>Pour les engins de récolte ou épandeurs automoteurs</i>	852423	1033	1654	732	4907	36.0TH			892	46
Bar	1 1.3 1.6	1.9	2.2	2.3	2.4	2.5	2.6	2.7	2.8		
Psi	15 19 23	28	32	33	35	36	38	39	41		
10 km/h	5815 6940 7740	8385	9025	9235	9450						
10 km/h Cyc		8290	9005	9725	9960	10200	10330	10455	10585	10710	
30 km/h	4145 4950 5670	6070	6475	6605	6740						
30 km/h Cyc		6565	7480	8390	8695	9000	9115	9225	9340	9450	
40 km/h	3875 4625 5300	5675	6050	6175	6300						
65 km/h	3255 3885 4450	4765	5080	5185	5290						

Ø pouces	Description	CAI	e mm	D mm	R' mm	Cdr mm	Jante(s) recommandée(s)	Jante(s) tolérée(s)	Chambre à air (Code)	Volume interne 75% (litres)	Profond. de sculpture (mm)	
26	750/50R26 160A8/154D TL <i>Pour les engins de récolte ou épandeurs automoteurs</i>	236906	742	1406	629	4171	DW25B (A)			466	39	
Bar	1 1.3 1.6	1.9	2.2	2.3	2.4	2.5	2.6	2.7	2.8	2.9	3.2	
Psi	15 19 23	28	32	33	35	36	38	39	41	42	46	
10 km/h	3750 4400 5175	5555	5935	6065	6190	6330	6470	6610	6750			
10 km/h Cyc		5230	5660	6090	6230	6375	6535	6695	6855	7015	7170	7650
30 km/h	2675 3135 3690	3960	4235	4325	4415	4515	4615	4715	4815			
30 km/h Cyc		4200	4735	5270	5445	5625	5765	5910	6050	6190	6330	6750
40 km/h	2500 2930 3450	3705	3955	4040	4125	4220	4310	4405	4500			
65 km/h	2100 2465 2900	3110	3325	3395	3465	3545	3620	3700	3780			

Ø pouces	Description	CAI	e mm	D mm	R' mm	Cdr mm	Jante(s) recommandée(s)	Jante(s) tolérée(s)	Chambre à air (Code)	Volume interne 75% (litres)	Profond. de sculpture (mm)		
32	650/75R32 172A8/172B TL	642277	638	1817	817	5397	DW21B (A)	DW20B (A) DW23B (A)	831	647	56		
Bar	1 1.3 1.6	1.9	2.2	2.3	2.4	2.5	2.6	2.7	2.8	2.9	3.2	3.5	3.8
Psi	15 19 23	28	32	33	35	36	38	39	41	42	46	51	55
10 km/h	4500 5220 5940	6420	6895	7055	7215	7375	7535	7695	7855	8015	8495	8970	9450
10 km/h Cyc	4900 5710 6520	7090	7665	7855	8045	8235	8425	8615	8805	8995	9565	10140	10710
25 km/h	3630 4235 4840	5245	5645	5780	5915	6050	6185	6320	6455	6590	6990		
30 km/h	3500 4085 4670	5060	5445	5575	5705	5835	5965	6095	6225	6355	6740		
40 km/h	3280 3820 4360	4725	5090	5210	5330	5450	5575	5695	5815	5935	6300		
50 km/h	3280 3820 4360	4725	5090	5210	5330	5450	5575	5695	5815	5935	6300		

* Se référer aux remarques en fin des tableaux de cette gamme

MICHELIN MEGAXBIB 2

Caractéristiques & Pression en bar / psi – Charges par pneu en kg*

Ø pouces	Description	CAI	e mm	D mm	R' mm	Cdr. mm	Jante(s) recommandée(s)		Jante(s) tolérée(s)	Chambre à air (Code)	Volume interne 75% (litres)	Profond. de sculpture (mm)			
32	800/65R32 178A8/1788 TL	135425	786	1839	832	5471	DW27B (A)		DW25B (A) DH27(B)	831	871	56.2			
Bar	1	1.3	1.6	1.9	2.2	2.3	2.4	2.5	2.6	2.7	2.8	2.9	3.2	3.5	3.8
Psi	15	19	23	28	32	33	35	36	38	39	41	42	46	51	55
10 km/h	5175	6060	6940	7600	8260	8480	8700	8890	9075	9265	9450	9630	10170	10710	11250
10 km/h Cyc	5865	7080	8290	8880	9470	9665	9860	10075	10285	10500	10710	10915	11525	12140	12750
25 km/h	4440	5165	5885	6300	6720	6855	6995	7160	7330	7495	7660	7825	8325		
30 km/h	4280	4975	5670	6070	6475	6605	6740	6900	7065	7225	7385	7545	8025		
40 km/h	4000	4650	5300	5675	6050	6175	6300	6450	6600	6750	6900	7050	7500		
50 km/h	4000	4650	5300	5675	6050	6175	6300	6450	6600	6750	6900	7050	7500		

Ø pouces	Description	CAI	e mm	D mm	R' mm	Cdr. mm	Jante(s) recommandée(s)		Jante(s) tolérée(s)	Chambre à air (Code)	Volume interne 75% (litres)	Profond. de sculpture (mm)
32	1050/50R32 178A8/172D TL <i>Pour les engins de récolte ou épandeurs automoteurs</i>	424273	1037	1866	828	5537	36.00VA				1233	42
Bar	1	1.3	1.6	1.9	2.2	2.3	2.4	2.5	2.6	2.7	2.8	
Psi	15	19	23	28	32	33	35	36	38	39	41	
10 km/h	6940	8260	9450	10125	10800	11025	11250					
10 km/h Cyc		9860	10690	11520	11795	12070	12240	12410	12580	12750		
30 km/h	4950	5890	6740	7220	7705	7865	8025					
30 km/h Cyc			7725	8820	9920	10285	10650	10800	10950	11100	11250	
40 km/h	4625	5505	6300	6750	7200	7350	7500					
65 km/h	3885	4625	5290	5670	6050	6175	6300					

Ø pouces	Description	CAI	e mm	D mm	R' mm	Cdr. mm	Jante(s) recommandée(s)		Jante(s) tolérée(s)	Chambre à air (Code)	Volume interne 75% (litres)	Profond. de sculpture (mm)			
32	900/60R32 181A8/181B TL	166896	862	1899	848	5635	DW27B (A)		DW30B (A)	831	1033	56.6			
Bar	1	1.3	1.6	1.9	2.2	2.3	2.4	2.5	2.6	2.7	2.8	2.9	3.2	3.5	3.8
Psi	15	19	23	28	32	33	35	36	38	39	41	42	46	51	55
10 km/h	5625	6675	7725	8485	9245	9495	9750	9975	10200	10425	10650	10825	11340	11860	12375
10 km/h Cyc	6375	7695	9010	9775	10540	10795	11050	11305	11560	11815	12070	12265	12850	13440	14025
25 km/h	4720	5580	6440	6980	7520	7700	7880	8060	8245	8425	8605	8745	9160		
30 km/h	4550	5380	6205	6725	7250	7420	7595	7770	7945	8120	8295	8430	8830		
40 km/h	4250	5025	5800	6290	6775	6940	7100	7265	7425	7590	7750	7875	8250		
50 km/h	4250	5025	5800	6290	6775	6940	7100	7265	7425	7590	7750	7875	8250		

* Se référer aux remarques en fin des tableaux de cette gamme

MICHELIN MEGAXBIB 2

Caractéristiques & Pression en bar / psi – Charges par pneu en kg*

Ø pouces	Description	CAI	e mm	D mm	R' mm	Cdr. mm	Jante(s) recommandée(s)	Jante(s) tolérée(s)	Chambre à air (Code)	Volume interne 75% (litres)	Profond. de sculpture (mm)				
32	800/70R32 181A8/181B TL NEW	366785	805	1938	893	5760	DW27B (A)	DW25B (A)	831	966	56.5				
Bar	1	1.3	1.6	1.9	2.2	2.3	2.4	2.5	2.6	2.7	2.8	2.9	3.2	3.5	3.8
Psi	15	19	23	28	32	33	35	36	38	39	41	42	46	51	55
10 km/h	5625	6675	7725	8830	9475	9615	9750	9900	10050	10200	10350	10555	11160	11770	12375
10 km/h Cyc	6375	7820	9265	9965	10625	10840	11050	11220	11390	11560	11730	11960	12650	13335	14025
20 km/h	5335	6360	7380	7795	8210	8345	8485	8695	8900	9110	9320	9525	10150		
25 km/h	4815	5740	6660	7035	7410	7535	7660	7850	8035	8225	8410	8600	9160		
30 km/h	4680	5550	6420	6780	7140	7260	7380	7560	7745	7925	8105	8285	8830		
40 km/h	4375	5190	6000	6340	6675	6790	6900	7070	7240	7405	7575	7745	8250		
50 km/h	4375	5190	6000	6340	6675	6790	6900	7070	7240	7405	7575	7745	8250		

Ø pouces	Description	CAI	e mm	D mm	R' mm	Cdr. mm	Jante(s) recommandée(s)	Jante(s) tolérée(s)	Chambre à air (Code)	Volume interne 75% (litres)	Profond. de sculpture (mm)				
34	710/75R34 178A8/178B TL NEW	312036	697	1909	857	5671	DW23B (A)	DW21B (A) MW23B (A)	765	863	56				
Bar	1	1.3	1.6	1.9	2.2	2.3	2.4	2.5	2.6	2.7	2.8	2.9	3.2	3.5	3.8
Psi	15	19	23	28	32	33	35	36	38	39	41	42	46	51	55
10 km/h	5700	6295	6890	7485	8080	8275	8475	8675	8870	9070	9270	9465	10060	10655	11250
10 km/h Cyc	6260	6955	7650	8345	9040	9275	9505	9735	9970	10200	10430	10665	11360	12055	12750
25 km/h	4650	5150	5655	6155	6655	6825	6990	7160	7325	7495	7660	7830	8330		
30 km/h	4480	4965	5450	5930	6415	6580	6740	6900	7060	7225	7385	7545	8030		
40 km/h	4190	4640	5095	5545	5995	6145	6295	6445	6595	6750	6900	7050	7500		
50 km/h	4190	4640	5095	5545	5995	6145	6295	6445	6595	6750	6900	7050	7500		

Ø pouces	Description	CAI	e mm	D mm	R' mm	Cdr. mm	Jante(s) recommandée(s)	Jante(s) tolérée(s)	Chambre à air (Code)	Volume interne 75% (litres)	Profond. de sculpture (mm)				
38	620/70R38 170A8/170B TL NEW	126128	605	1866	853	5565	DW20B (A)	DW18L	825	592	56.5				
Bar	1	1.3	1.6	1.9	2.2	2.3	2.4	2.5	2.6	2.7	2.8	2.9	3.2	3.5	3.8
Psi	15	19	23	28	32	33	35	36	38	39	41	42	46	51	55
10 km/h	4560	5035	5510	5985	6465	6620	6780	6940	7095	7255	7415	7575	8050	8525	9000
10 km/h Cyc	5010	5565	6120	6680	7235	7420	7605	7790	7975	8160	8345	8530	9090	9645	10200
25 km/h	3710	4110	4515	4915	5320	5455	5585	5720	5855	5990	6125	6260	6660		
30 km/h	3580	3965	4355	4740	5130	5260	5385	5515	5645	5775	5905	6035	6420		
40 km/h	3350	3710	4075	4435	4795	4915	5035	5155	5275	5400	5520	5640	6000		
50 km/h	3350	3710	4075	4435	4795	4915	5035	5155	5275	5400	5520	5640	6000		

* Se référer aux remarques en fin des tableaux de cette gamme

MICHELIN MEGAXBIB 2

Caractéristiques & Pression en bar / psi – Charges par pneu en kg*

*REMARQUES

La pression de gonflage se détermine toujours en fonction de la charge par pneu, de la vitesse et du travail à réaliser.

Nos préconisations ci-dessus sont fournies sous réserve de modifications postérieures à la date de diffusion de ces tableaux (mars 2021).

Les données techniques sont susceptibles d'évoluer sans information préalable.

- Pour les machines standard ou à correction de dévers travaillant sur des pentes >20% (11°), utiliser la ligne 10 km/h non cyclique.
- Pour les engins de récolte, utiliser la ligne à 10 km/h non cyclique et, pour les flotteurs, utiliser la ligne à 30 km/h non cyclique.
- Pour usage routier intensif >50% : ajouter 0,4 bar.
- 10 km/h ou 15 km/h Cyc :
Travaux de récolte avec charge cyclique, utilisation champ uniquement.



MICHELIN MEGAXBIB

**EXCELLENT RAPPORT
QUALITÉ/PRIX POUR
LES ENGINES DE RÉCOLTE**



POUR LES ENGINES DE RÉCOLTE



CAPACITÉ DE CHARGE

- Jusqu'à 30 600 kg ⁽¹⁾ par essieu



ENDURANCE

- Jusqu'à +46% ⁽²⁾ par rapport au principal concurrent



CONFORT



(1) 1050/50 R32 184A8/184B – 10 km/h cyclique

(2) Test interne (Ladoux - France) étude sur 800/65R32 178A8/178B

DIMENSIONS

750/50R26 160A8/154D TL

620/75R26 166A8/166B TL

750/65R26 171A8/171B TL

620/75R30 168A8/168B TL

650/75R32 172A8/172B TL

800/65R32 178A8/178B TL

1050/50R32 184A8/184B TL

900/60R32 181A8/181B TL

1050/50R32 178A8 TL

800/70R32 181A8/181B TL

620/75R34 170A8/170B TL

710/75R34 178A8/178B TL

620/70R38 170A8/170B TL

650/85R38 173A8/173B TL

520/85R42 162A8/162B TL

620/70R42 166A8/166B TL

MICHELIN MEGAXBIB

Caractéristiques & Pression en bar / psi – Charges par pneu en kg*

Ø pouces	Description	CAI	e mm	D mm	R' mm	Cdr mm	Jante(s) recommandée(s)	Jante(s) tolérée(s)	Chambre à air (Code)	Volume interne 75% (litres)	Profond. de sculpture (mm)		
26	750/50R26 160A8/154D TL	478428	738	1404	625	4162	DW25B (A)			458	37		
Bar	1	1.3	1.6	1.9	2.2	2.3	2.4	2.5	2.6	2.7	2.8	2.9	3.2
Psi	15	19	23	28	32	33	35	36	38	39	41	42	46
10 km/h	3750	4395	5175	5555	5935	6065	6190	6330	6470	6610	6750		
10 km/h Cyc			5230	5660	6090	6230	6375	6535	6695	6855	7015	7170	7650
30 km/h	2675	3135	3690	3960	4235	4325	4415	4515	4615	4715	4815		
30 km/h Cyc			4200	4735	5270	5445	5625	5765	5910	6050	6190	6330	6750
40 km/h	2500	2930	3450	3705	3955	4040	4125	4220	4315	4405	4500		
65 km/h	2100	2465	2900	3110	3325	3395	3465	3545	3625	3700	3780		

Ø pouces	Description	CAI	e mm	D mm	R' mm	Cdr mm	Jante(s) recommandée(s)	Jante(s) tolérée(s)	Chambre à air (Code)	Volume interne 75% (litres)	Profond. de sculpture (mm)				
26	620/75R26 166A8/166B TL	614320	588	1602	712	4748	DW20B (A)	DW18L	830	516	46				
Bar	1	1.3	1.6	1.9	2.2	2.3	2.4	2.5	2.6	2.7	2.8	2.9	3.2	3.5	3.8
Psi	15	19	23	28	32	33	35	36	38	39	41	42	46	51	55
10 km/h	3910	4405	4900	5315	5730	5870	6010	6150	6285	6425	6565	6700	7120	7535	7950
10 km/h Cyc	4410	4820	5230	5745	6260	6435	6605	6775	6950	7120	7290	7465	7980	8495	9010
25 km/h	3170	3610	4050	4395	4735	4850	4965	5080	5195	5310	5425	5535	5880		
30 km/h	3060	3480	3900	4230	4565	4675	4785	4895	5005	5115	5230	5340	5670		
40 km/h	2860	3250	3640	3950	4265	4365	4470	4575	4680	4780	4885	4990	5300		
50 km/h	2860	3250	3640	3950	4265	4365	4470	4575	4680	4780	4885	4990	5300		

Ø pouces	Description	CAI	e mm	D mm	R' mm	Cdr mm	Jante(s) recommandée(s)	Jante(s) tolérée(s)	Chambre à air (Code)	Volume interne 75% (litres)	Profond. de sculpture (mm)				
26	750/65R26 171A8/171B TL	983217	732	1621	730	4818	DW25B (A)			833	677	46			
Bar	1	1.3	1.6	1.9	2.2	2.3	2.4	2.5	2.6	2.7	2.8	2.9	3.2	3.5	3.8
Psi	15	19	23	28	32	33	35	36	38	39	41	42	46	51	55
10 km/h	4350	5080	5760	6380	6940	7110	7285	7460	7630	7775	7920	8060	8460	8845	9225
10 km/h Cyc	4930	5865	6675	7360	7920	8100	8285	8470	8650	8815	8975	9140	9590	10020	10455
25 km/h	3610	4175	4735	5240	5630	5765	5895	6030	6160	6270	6380	6495	6825		
30 km/h	3480	4025	4570	5055	5420	5550	5680	5810	5940	6045	6155	6260	6580		
40 km/h	3250	3760	4265	4720	5070	5190	5310	5430	5550	5650	5750	5850	6150		
50 km/h	3250	3760	4265	4720	5070	5190	5310	5430	5550	5650	5750	5850	6150		

* Se référer aux remarques en fin des tableaux de cette gamme

MICHELIN MEGAXBIB

Caractéristiques & Pression en bar / psi – Charges par pneu en kg*

Ø pouces	Description	CAI	e mm	D mm	R' mm	Cdr mm	Jante(s) recommandée(s)	Jante(s) tolérée(s)	Chambre à air (Code)	Volume interne 75% (litres)	Profond. de sculpture (mm)				
30	620/75R30 168A8/1688 TL	753673	604	1710	770	5083	DW20B (A)	DW18L	737	559	46				
Bar	1	1.3	1.6	1.9	2.2	2.3	2.4	2.5	2.6	2.7	2.8	2.9	3.2	3.5	3.8
Psi	15	19	23	28	32	33	35	36	38	39	41	42	46	51	55
10 km/h	4130	4650	5170	5610	6050	6200	6345	6490	6640	6785	6930	7080	7520	7960	8400
10 km/h Cyc	4660	5090	5520	6065	6610	6795	6975	7155	7340	7520	7700	7885	8430	8975	9520
25 km/h	3360	3815	4270	4635	5000	5120	5240	5360	5485	5605	5725	5845	6210		
30 km/h	3240	3680	4120	4470	4820	4940	5055	5170	5290	5405	5525	5640	5990		
40 km/h	3030	3440	3850	4180	4505	4615	4725	4835	4945	5055	5165	5270	5600		
50 km/h	3030	3440	3850	4180	4505	4615	4725	4835	4945	5055	5165	5270	5600		

Ø pouces	Description	CAI	e mm	D mm	R' mm	Cdr mm	Jante(s) recommandée(s)	Jante(s) tolérée(s)	Chambre à air (Code)	Volume interne 75% (litres)	Profond. de sculpture (mm)				
32	650/75R32 172A8/1728 TL	468227	657	1825	821	5423	DW21B (A)	DW20B (A) DW23B (A)	831	698	59				
Bar	1	1.3	1.6	1.9	2.2	2.3	2.4	2.5	2.6	2.7	2.8	2.9	3.2	3.5	3.8
Psi	15	19	23	28	32	33	35	36	38	39	41	42	46	51	55
10 km/h	4500	5220	5940	6420	6895	7055	7215	7375	7535	7695	7855	8015	8495	8970	9450
10 km/h Cyc	4900	5710	6520	7090	7665	7855	8045	8235	8425	8615	8805	8995	9565	10140	10710
25 km/h	3630	4235	4840	5245	5645	5780	5915	6050	6185	6320	6455	6585	6990		
30 km/h	3500	4085	4670	5060	5445	5575	5705	5835	5965	6095	6225	6350	6740		
40 km/h	3280	3820	4360	4725	5090	5210	5330	5450	5575	5695	5815	5935	6300		
50 km/h	3280	3820	4360	4725	5090	5210	5330	5450	5575	5695	5815	5935	6300		

Ø pouces	Description	CAI	e mm	D mm	R' mm	Cdr mm	Jante(s) recommandée(s)	Jante(s) tolérée(s)	Chambre à air (Code)	Volume interne 75% (litres)	Profond. de sculpture (mm)				
32	800/65R32 178A8/1788 TL	521809	793	1840	822	5459	DW27B (A)	DW25B (A) DHB27	831	903	56				
Bar	1	1.3	1.6	1.9	2.2	2.3	2.4	2.5	2.6	2.7	2.8	2.9	3.2	3.5	3.8
Psi	15	19	23	28	32	33	35	36	38	39	41	42	46	51	55
10 km/h	5175	6060	6940	7600	8260	8480	8700	8890	9075	9265	9450	9630	10170	10710	11250
10 km/h Cyc	5865	7080	8290	8880	9470	9665	9860	10075	10285	10500	10710	10915	11525	12140	12750
25 km/h	4440	5165	5885	6300	6720	6855	6995	7160	7330	7495	7660	7825	8325		
30 km/h	4280	4975	5670	6070	6475	6605	6740	6900	7065	7225	7385	7545	8025		
40 km/h	4000	4650	5300	5675	6050	6175	6300	6450	6600	6750	6900	7050	7500		
50 km/h	4000	4650	5300	5675	6050	6175	6300	6450	6600	6750	6900	7050	7500		

* Se référer aux remarques en fin des tableaux de cette gamme

MICHELIN MEGAXBIB

Caractéristiques & Pression en bar / psi – Charges par pneu en kg*

Ø pouces	Description	CAI	e mm	D mm	R' mm	Cdr mm	Jante(s) recommandée(s)		Jante(s) tolérée(s)	Chambre à air (Code)	Volume interne 75% (litres)	Profond. de sculpture (mm)
32	1050/50R32 184A8/184B TL <i>Pneu pour engin d'épandage</i>	829536	1040	1856	831	5510	36.00VA				1159	41
Bar	1 1.3 1.6 1.9 2.2 2.3 2.4 2.5 2.6 2.7 2.8 2.9 3.2 3.5 3.8											
Psi	15 19 23 28 32 33 35 36 38 39 41 42 46 51 55											
10 km/h Cyc	6800 8330 9860 10710 11475 11730 11985 12240 12495 12750 13005 13260 14025 14665 15300											
25 km/h	5135 6065 6995 7495 7995 8160 8325 8535 8745 8950 9160 9370 9990											
30 km/h	4950 5845 6740 7220 7705 7865 8025 8225 8430 8630 8830 9030 9630											
30 km/h Cyc	6240 7370 8500 9045 9695 9910 10125 10380 10630 10885 11140 11390 12150 12825 13500											
40 km/h	4625 5465 6300 6750 7200 7350 7500 7690 7875 8065 8250 8440 9000											
50 km/h	4625 5465 6300 6750 7200 7350 7500 7690 7875 8065 8250 8440 9000											

Ø pouces	Description	CAI	e mm	D mm	R' mm	Cdr mm	Jante(s) recommandée(s)		Jante(s) tolérée(s)	Chambre à air (Code)	Volume interne 75% (litres)	Profond. de sculpture (mm)
32	900/60R32 181A8/181B TL	824122	868	1894	850	5626	DW27B (A)		DW30B (A)	831	1033	56
Bar	1 1.3 1.6 1.9 2.2 2.3 2.4 2.5 2.6 2.7 2.8 2.9 3.2 3.5 3.8											
Psi	15 19 23 28 32 33 35 36 38 39 41 42 46 51 55											
10 km/h	5625 6675 7725 8485 9245 9495 9750 9975 10200 10425 10650 10825 11340 11860 12375											
10 km/h Cyc	6375 7695 9010 9775 10540 10795 11050 11305 11560 11815 12070 12265 12850 13440 14025											
25 km/h	4720 5580 6440 6980 7520 7700 7880 8060 8245 8425 8605 8745 9160											
30 km/h	4550 5380 6205 6725 7250 7420 7595 7770 7945 8120 8295 8430 8830											
50 km/h	4250 5025 5800 6290 6775 6940 7100 7265 7425 7590 7750 7875 8250											

Ø pouces	Description	CAI	e mm	D mm	R' mm	Cdr mm	Jante(s) recommandée(s)		Jante(s) tolérée(s)	Chambre à air (Code)	Volume interne 75% (litres)	Profond. de sculpture (mm)
32	1050/50R32 178A8 TL <i>M28</i>	236234	1038	1902	854	5649	36.00VA				1250	60
Bar	1 1.3 1.6 1.9 2.2 2.3 2.4 2.5 2.6 2.7 2.8											
Psi	15 19 23 28 32 33 35 36 38 39 41											
10 km/h	6860 7925 8990 9605 10225 10430 10635 10840 11045 11250											
10 km/h Cyc	7420 8630 9840 10635 11425 11690 11955 12220 12485 12750											
15 km/h Cyc	5350 6675 8000 9330 10390 10700 11010 11165 11320 11475 11630											
25 km/h	5570 6505 7440 7775 8110 8220 8330											
30 km/h	5370 6270 7170 7495 7815 7925 8030											
40 km/h	5020 5860 6700 7000 7300 7400 7500											

* Se référer aux remarques en fin des tableaux de cette gamme

MICHELIN MEGAXBIB

Caractéristiques & Pression en bar / psi – Charges par pneu en kg*

Ø pouces	Description	CAI	e mm	D mm	R' mm	Cdr. mm	Jante(s) recommandée(s)	Jante(s) tolérée(s)	Chambre à air (Code)	Volume interne 75% (litres)	Profond. de sculpture (mm)				
32	800/70R32 181A8/181B TL	695992	793	1936	871	5725	DW27B (A)	DW25B (A)	831	966	58				
Bar	1	1.3	1.6	1.9	2.2	2.3	2.4	2.5	2.6	2.7	2.8	2.9	3.2	3.5	3.8
Psi	15	19	23	28	32	33	35	36	38	39	41	42	46	51	55
10 km/h	5625	6675	7725	8830	9475	9615	9750	9900	10050	10200	10350	10555	11160	11770	12375
10 km/h Cyc	6375	7820	9265	9965	10625	10840	11050	11220	11390	11560	11730	11960	12650	13335	14025
20 km/h	5335	6360	7380	7795	8210	8345	8485	8695	8900	9110	9320	9525	10150		
25 km/h	4815	5740	6660	7035	7410	7535	7660	7850	8035	8225	8410	8600	9160		
30 km/h	4680	5550	6420	6780	7140	7260	7380	7560	7745	7925	8105	8285	8830		
40 km/h	4375	5190	6000	6340	6675	6790	6900	7070	7240	7405	7575	7745	8250		
50 km/h	4375	5190	6000	6340	6675	6790	6900	7070	7240	7405	7575	7745	8250		

Ø pouces	Description	CAI	e mm	D mm	R' mm	Cdr. mm	Jante(s) recommandée(s)	Jante(s) tolérée(s)	Chambre à air (Code)	Volume interne 75% (litres)	Profond. de sculpture (mm)				
34	620/75R34 170A8/170B TL	325025	590	1814	821	5398	DW20B (A)	DW18L		612	46				
Bar	1	1.3	1.6	1.9	2.2	2.3	2.4	2.5	2.6	2.7	2.8	2.9	3.2	3.5	3.8
Psi	15	19	23	28	32	33	35	36	38	39	41	42	46	51	55
10 km/h	4560	5035	5510	5985	6465	6620	6780	6940	7095	7255	7415	7575	8050	8525	9000
10 km/h Cyc	5010	5565	6120	6680	7235	7420	7605	7790	7975	8160	8345	8530	9090	9645	10200
25 km/h	3710	4110	4515	4915	5320	5455	5585	5720	5855	5990	6125	6260	6660		
30 km/h	3580	3965	4355	4740	5130	5260	5385	5515	5645	5775	5905	6035	6420		
40 km/h	3350	3710	4075	4435	4795	4915	5035	5155	5275	5400	5520	5640	6000		
50 km/h	3350	3710	4075	4435	4795	4915	5035	5155	5275	5400	5520	5640	6000		

Ø pouces	Description	CAI	e mm	D mm	R' mm	Cdr. mm	Jante(s) recommandée(s)	Jante(s) tolérée(s)	Chambre à air (Code)	Volume interne 75% (litres)	Profond. de sculpture (mm)				
34	710/75R34 178A8/178B TL	543107	690	1900	848	5637	DW23B (A)	DW21B (A) MW23B (A)	765	863	58				
Bar	1	1.3	1.6	1.9	2.2	2.3	2.4	2.5	2.6	2.7	2.8	2.9	3.2	3.5	3.8
Psi	15	19	23	28	32	33	35	36	38	39	41	42	46	51	55
10 km/h	5700	6295	6890	7485	8080	8275	8475	8675	8870	9070	9270	9465	10060	10655	11250
10 km/h Cyc	6260	6955	7650	8345	9040	9275	9505	9735	9970	10200	10430	10665	11360	12055	12750
25 km/h	4650	5150	5655	6155	6655	6825	6990	7160	7325	7495	7660	7830	8330		
30 km/h	4480	4965	5450	5930	6415	6580	6740	6900	7060	7225	7385	7545	8030		
40 km/h	4190	4640	5095	5545	5995	6145	6295	6445	6595	6750	6900	7050	7500		
50 km/h	4190	4640	5095	5545	5995	6145	6295	6445	6595	6750	6900	7050	7500		

* Se référer aux remarques en fin des tableaux de cette gamme

MICHELIN MEGAXBIB

Caractéristiques & Pression en bar / psi – Charges par pneu en kg*

Ø pouces	Description	CAI	e mm	D mm	R' mm	Cdr mm	Jante(s) recommandée(s)	Jante(s) tolérée(s)	Chambre à air (Code)	Volume interne 75% (litres)	Profond. de sculpture (mm)				
38	620/70R38 170A8/170B TL	476088	608	1864	850	5557	DW20B (A)	DW18L	825	587	55				
Bar	1	1.3	1.6	1.9	2.2	2.3	2.4	2.5	2.6	2.7	2.8	2.9	3.2	3.5	3.8
Psi	15	19	23	28	32	33	35	36	38	39	42	46	46	51	55
10 km/h	4560	5035	5510	5985	6465	6620	6780	6940	7095	7255	7415	7575	8050	8525	9000
10 km/h Cyc	5010	5565	6120		7235	7420	7605	7790	7975	8160	8345	8530	9090	9645	10200
25 km/h	3710	4110	4515	4915	5320	5455	5585	5720	5855	5990	6125	6260	6660		
30 km/h	3580	3965	4355	4740	5130	5260	5385	5515	5645	5775	5905	6035	6420		
40 km/h	3350	3710	4075	4435	4795	4915	5035	5155	5275	5400	5520	5640	6000		
50 km/h	3350	3710	4075	4435	4795	4915	5035	5155	5275	5400	5520	5640	6000		

Ø pouces	Description	CAI	e mm	D mm	R' mm	Cdr mm	Jante(s) recommandée(s)	Jante(s) tolérée(s)	Chambre à air (Code)	Volume interne 75% (litres)	Profond. de sculpture (mm)
38	650/85R38 173A8/173B TL <i>Sommet textile</i>	173491	699	2048	931	6100	DW23B (A)	DW20B (A)	804	857	63
Bar	1	1.3	1.6	1.9	2.2	2.3	2.4	2.5	2.6	2.7	2.8
Psi	15	19	23	28	32	33	35	35	38	39	41
10 km/h	5815	6660	7500	8065	8625	8815	9000	9190	9375	9565	9750
10 km/h Cyc Dual	5610	6545	7480	8040	8600	8790	8975	9165	9350	9535	9725
25 km/h	4440	5245	6050	6485	6925	7070	7215				
30 km/h	4280	5055	5830	6250	6675	6815	6955				
40 km/h	4000	4725	5450	5845	6240	6370	6500				
50 km/h	4000	4725	5450	5845	6240	6370	6500				

Ø pouces	Description	CAI	e mm	D mm	R' mm	Cdr mm	Jante(s) recommandée(s)	Jante(s) tolérée(s)	Chambre à air (Code)	Volume interne 75% (litres)	Profond. de sculpture (mm)
42	520/85R42 162A8/162B TL <i>Sommet textile</i>	645194	537	1937	889	5783	DW18L	DD18 W18L	802	545	56
Bar	1	1.3	1.6	1.9	2.2	2.3	2.4	2.5	2.6	2.7	
Psi	15	19	23	28	32	33	35	36	38	39	
10 km/h	3990	4900	5810	6395	6830	6975	7070	7170	7265	7360	
10 km/h Cyc Dual	3850	4575	5300	6170	6500	6620	6740	6865	6985	7105	
25 km/h	3330	3955	4580	4890	5135	5205	5275				
30 km/h	3210	3815	4415	4715	4950	5020	5085				
30 km/h Dual	2825	3355	3885	4150	4355	4415	4475				
50 km/h	3000	3565	4125	4405	4625	4690	4750				

* Se référer aux remarques en fin des tableaux de cette gamme

MICHELIN MEGAXBIB

Caractéristiques & Pression en bar / psi – Charges par pneu en kg*

Ø pouces	Description	CAI	e mm	D mm	R' mm	Cdr mm	Jante(s) recommandée(s)		Jante(s) tolérée(s)	Chambre à air (Code)	Volume interne 75% (litres)	Profond. de sculpture (mm)
42	620/70R42 166A8/166B TL <i>Sommet textile</i>	100268	639	1961	885	5857	DW20B (A)		DW18L MW20B (A)	802	658	56
Bar	1 1.3 1.6 1.9 2.2 2.3 2.4 2.5 2.6 2.7 2.8											
Psi	15 19 23 28 32 33 35 36 38 39 41											
10 km/h	4090 4890 5685 6485 7050 7200 7350 7500 7650 7800 7950											
10 km/h Cyc Dual	4080 4875 5670 6465 7030 7180 7330 7480 7630 7780 7930											
30 km/h Dual	3060 3650 4240 4520 4805 4895 4990											
40 km/h	3250 3875 4500 4800 5100 5200 5300											
50 km/h	3250 3875 4500 4800 5100 5200 5300											

*REMARQUES

La pression de gonflage se détermine toujours en fonction de la charge par pneu, de la vitesse et du travail à réaliser.

Nos préconisations ci-dessus sont fournies sous réserve de modifications postérieures à la date de diffusion de ces tableaux (mars 2021).

Les données techniques sont susceptibles d'évoluer sans information préalable.

- Pour les machines standard ou à correction de dévers travaillant sur des pentes >20% (11°), utiliser la ligne 10 km/h non cyclique.
- Pour usage routier intensif >50% : ajouter 0,4 bar.
- 10, 15 ou 30 km/h Cyc: Utilisation champ uniquement, sur une distance de 1,5km maximum



MICHELIN SPRAYBIB

**FORTE CAPACITÉ DE CHARGE
POUR PULVÉRISATEURS**



POUR PULVÉRISATEUR



(VF) Très basse pression



PRODUCTIVITÉ

- +16%⁽¹⁾ de charge vs un pneu IF à pression égale.



PROTECTION DES SOLS

- Pression d'air 25%⁽¹⁾ plus basse pour la même charge qu'un pneu IF.



CONFORT

- Stabilité maximale à hautes vitesses (jusqu'à 65 km/h)

(1) Test interne 2015 (Ladoux – France)

DIMENSIONS

VF 380/80R38 167D TL

VF 320/90R42 163D TL

VF 480/80R42 176D TL

VF 320/90R46 165D TL **NEW**

VF 380/90R46 173D TL

VF 480/80R46 177D TL

VF 320/90R50 166D TL

VF 380/90R50 175D TL

VF 480/80R50 179D TL

VF 420/95R50 177D TL

VF 320/90R54 168D TL

VF 380/90R54 176D TL

MICHELIN SPRAYBIB

Caractéristiques & Pression en bar / psi – Charges par pneu en kg*

Ø pouces	Description	CAI	e mm	D mm	R' mm	Cdr mm	Jante(s) recommandée(s)	Jante(s) tolérée(s)	Chambre à air (Code)	Volume interne 75% (litres)	Profond. de sculpture (mm)			
38	VF 380/80R38 167D TL	352109	382	1577	726	4712	DW13	DW12	795	231	38			
Bar	1.8	2	2.2	2.4	2.6	2.8	3	3.2	3.4	3.6	3.8	4	4.2	4.4
Psi	26	29	32	35	38	41	44	46	49	52	55	58	61	64
65 km/h	3100	3375	3650	3750	3940	4125	4315	4500	4625	4750	4875	5000	5225	5450

Ø pouces	Description	CAI	e mm	D mm	R' mm	Cdr mm	Jante(s) recommandée(s)	Jante(s) tolérée(s)	Chambre à air (Code)	Volume interne 75% (litres)	Profond. de sculpture (mm)			
42	VF 320/90R42 163D TL	920383	332	1635	758	4890	DW11	DW10		195	36			
Bar	1.8	2	2.2	2.4	2.6	2.8	3	3.2	3.4	3.6	3.8	4	4.2	4.4
Psi	26	29	32	35	38	41	44	46	49	52	55	58	61	64
65 km/h	2815	3025	3250	3350	3500	3650	3825	4000	4125	4250	4405	4565	4720	4875

Ø pouces	Description	CAI	e mm	D mm	R' mm	Cdr mm	Jante(s) recommandée(s)	Jante(s) tolérée(s)	Chambre à air (Code)	Volume interne 75% (litres)	Profond. de sculpture (mm)			
42	VF 480/80R42 176D TL	929553	489	1838	833	5471	DW16A	DD16 W16A	801	420	38			
Bar	1.8	2	2.2	2.4	2.6	2.8	3	3.2	3.4	3.6	3.8	4	4.2	4.4
Psi	26	29	32	35	38	41	44	46	49	52		58	61	64
65 km/h	5000	5200	5400	5600	5875	6150	6425	6700	6900	7100				

Ø pouces	Description	CAI	e mm	D mm	R' mm	Cdr mm	Jante(s) recommandée(s)	Jante(s) tolérée(s)	Chambre à air (Code)	Volume interne 75% (litres)	Profond. de sculpture (mm)			
46	VF 320/90R46 165D TL NEW	684579	318	1736	810	5350	DW10		835	211	37			
Bar	1.8	2	2.2	2.4	2.6	2.8	3	3.2	3.4	3.6	3.8	4	4.2	4.4
Psi	26	29	32	35	38	41	44	46	49	52	55	58	61	64
65 km/h	3000	3230	3450	3550	3715	3875	4000	4125	4315	4500	4665	4825	4990	5150

Ø pouces	Description	CAI	e mm	D mm	R' mm	Cdr mm	Jante(s) recommandée(s)	Jante(s) tolérée(s)	Chambre à air (Code)	Volume interne 75% (litres)	Profond. de sculpture (mm)			
46	VF 380/90R46 173D TL	198604	383	1842	848	5530	DW13A	DW12A W12A W12 W13A W13	835	308	38			
Bar	1.8	2	2.2	2.4	2.6	2.8	3	3.2	3.4	3.6	3.8	4	4.2	4.4
Psi	26	29	32	35	38	41	44	46	49	52	55	58	61	64
65 km/h	3725	4050	4375	4625	4815	5000	5225	5450	5625	5800	5900	6000	6250	6500

* Se référer aux remarques en fin des tableaux de cette gamme

MICHELIN SPRAYBIB

Caractéristiques & Pression en bar / psi – Charges par pneu en kg*

Ø pouces	Description	CAI	e mm	D mm	R' mm	Cdr. mm	Jante(s) recommandée(s)	Jante(s) tolérée(s)	Chambre à air (Code)	Volume interne 75% (litres)	Profond. de sculpture (mm)
46	VF 480/80R46 177D TL	159186	485	1943	885	5790	DW16A (L)	W16A DW15L DW16B	834	449	38
Bar	1.8	2	2.2	2.4	2.6	2.8	3	3.2	3.4	3.6	
Psi	26	29	32	35	38	41	44	46	49	52	
65 km/h	5300	5465	5635	5800	6075	6350	6625	6900	7100	7300	

Ø pouces	Description	CAI	e mm	D mm	R' mm	Cdr. mm	Jante(s) recommandée(s)	Jante(s) tolérée(s)	Chambre à air (Code)	Volume interne 75% (litres)	Profond. de sculpture (mm)	
50	VF 320/90R50 166D TL	946508	330	1844	864	5531	DW11	DW10 W10 W11	816	240	37	
Bar	1.8	2	2.2	2.4	2.6	2.8	3	3.2	3.4	3.6	3.8	
Psi	26	29	32	35	38	41	44	46	49	52	55	
65 km/h	3040	3300	3650	3750	3875	4000	4190	4375	4500	4625	4795	
										4965	5130	5300

Ø pouces	Description	CAI	e mm	D mm	R' mm	Cdr. mm	Jante(s) recommandée(s)	Jante(s) tolérée(s)	Chambre à air (Code)	Volume interne 75% (litres)	Profond. de sculpture (mm)	
50	VF 380/90R50 175D TL	722276	384	1951	903	5836	DW13B	DW12A W12A W13A W13B W12B		329	38	
Bar	1.8	2	2.2	2.4	2.6	2.8	3	3.2	3.4	3.6	3.8	
Psi	26	29	32	35	38	41	44	46	49	52	55	
65 km/h	3950	4300	4625	4750	4950	5150	5375	5600	5800	6000	6150	
										6300	6600	6900

Ø pouces	Description	CAI	e mm	D mm	R' mm	Cdr. mm	Jante(s) recommandée(s)	Jante(s) tolérée(s)	Chambre à air (Code)	Volume interne 75% (litres)	Profond. de sculpture (mm)
50	VF 480/80R50 179D TL	431251	485	2045	935	6101	DW16A(L)	DW15L DW15B (A) W15B (A) DW16B W16B		479	38
Bar	1.8	2	2.2	2.4	2.6	2.8	3	3.2	3.4	3.6	
Psi	26	29	32	35	38	41	44	46	49	52	
65 km/h	5450	5685	5915	6150	6440	6725	7015	7300	7525	7750	

Ø pouces	Description	CAI	e mm	D mm	R' mm	Cdr. mm	Jante(s) recommandée(s)	Jante(s) tolérée(s)	Chambre à air (Code)	Volume interne 75% (litres)	Profond. de sculpture (mm)
50	VF 420/95R50 177D TL	085405	423	2052	937	6118	DW14B (A)	DW13B (A) W13B (A) W14B (A)		440	38
Bar	1.8	2	2.2	2.4	2.6	2.8	3	3.2	3.4	3.6	
Psi	26	29	32	35	38	41	44	46	49	52	
65 km/h	5150	5365	5585	5800	6075	6350	6625	6900	7100	7300	

* Se référer aux remarques en fin des tableaux de cette gamme

MICHELIN SPRAYBIB

Caractéristiques & Pression en bar / psi – Charges par pneu en kg*

Ø pouces	Description	CAI	e mm	D mm	R' mm	Cdr mm	Jante(s) recommandée(s)	Jante(s) tolérée(s)	Chambre à air (Code)	Volume interne 75% (litres)	Profond. de sculpture (mm)			
54	VF 320/90R54 168D TL	044008	327	1950	909	5843	DW11	DW10 W10 W11	816	240	36			
Bar	1.8	2	2.2	2.4	2.6	2.8	3	3.2	3.4	3.6	3.8	4	4.2	4.4
Psi	26	29	32	35	38	41	44	46	49	52	55	58	61	64
65 km/h	3225	3500	3750	3875	4065	4250	4440	4625	4750	4875	5055	5240	5420	5600

Ø pouces	Description	CAI	e mm	D mm	R' mm	Cdr mm	Jante(s) recommandée(s)	Jante(s) tolérée(s)	Chambre à air (Code)	Volume interne 75% (litres)	Profond. de sculpture (mm)			
54	VF 380/90R54 176D TL	816598	384	2049	950	6131	DW13A	W12A		350	37			
Bar	1.8	2	2.2	2.4	2.6	2.8	3	3.2	3.4	3.6	3.8	4	4.2	4.4
Psi	26	29	32	35	38	41	44	46	49	52	55	58	61	64
65 km/h	4175	4525	4875	5000	5190	5375	5565	5750	5940	6125	6315	6500	6800	7100

*REMARQUES

La pression de gonflage se détermine toujours en fonction de la charge par pneu, de la vitesse et du travail à réaliser.

Nos préconisations ci-dessus sont fournies sous réserve de modifications postérieures à la date de diffusion de ces tableaux (mars 2021).

Les données techniques sont susceptibles d'évoluer sans information préalable.

- Pour usage en dévers >20% : ajouter 0,4 bar.
- Pour usage routier intensif >50% : ajouter 0,4 bar.



MICHELIN AGRIBIB ROW CROP

**SPÉCIALEMENT CONÇU
POUR LE TRAVAIL
DES CUTURES EN LIGNE**



POUR PULVÉRISATEUR



TRACTION



PROTECTION DES CULTURES



DIMENSIONS

IF 320/85R38 151A8/151B TL

320/85R38 143A8/143B TL

320/90R42 147A8/147B TL

340/85R46 150A8/150B TL

IF 380/90R46 165A8/165B TL

380/90R46 157A8/157B TL

320/90R50 150A8/150B TL

IF 320/90R50 158A8/158B TL

380/90R50 151A8/151B TL

IF 380/90R50 167A8/167B TL **NEW**

IF 320/90R54 159A8/159B TL

320/90R54 151A8/151B TL

MICHELIN AGRIBIB ROW CROP

Caractéristiques & Pression en bar / psi – Charges par pneu en kg*

Ø pouces	Description	CAI	e mm	D mm	R' mm	Cdr. mm	Jante(s) recommandée(s)		Jante(s) tolérée(s)	Chambre à air (Code)	Volume interne 75% (litres)	Profond. de sculpture (mm)			
38	IF 320/85R38 151A8/151B TL	351097	330	1506	697	4496	DW11A		DW10A W10 W11		170	41			
Bar	1.2	1.4	1.6	1.8	2	2.2	2.4	2.6	2.8	3	3.2	3.4	3.6	3.8	4
Psi	17	20	23	26	29	32	35	38	41	44	46	49	52	55	58
10 km/h	2025	2250	2475	2590	2700	2790	2875	3015	3150	3275	3400	3515	3625	3715	3800
20 km/h	1975	2200	2425	2540	2650	2740	2825	2965	3100	3225	3350	3465	3575	3650	3725
30 km/h	1900	2115	2325	2440	2550	2640	2725	2850	2975	3100	3225	3325	3425	3515	3600
50 km/h	1825	2040	2250	2350	2450	2540	2625	2750	2875	2990	3100	3200	3300	3375	3450

Ø pouces	Description	CAI	e mm	D mm	R' mm	Cdr. mm	Jante(s) recommandée(s)		Jante(s) tolérée(s)	Chambre à air (Code)	Volume interne 75% (litres)	Profond. de sculpture (mm)			
38	320/85R38 143A8/143B TL	758001	315	1508	699	4514	W10		DW10A DW11A W11	779	170	42			
Bar	1.2	1.4	1.6	1.8	2	2.2	2.4	2.6	2.8	3	3.2	3.4	3.6	3.8	4
Psi	17	20	23	26	29	32	35	38	41	44	46	49	52	55	58
10 km/h Cyc			2330	2520	2710	2900	3090	3205	3315	3430	3540	3700	3860	3975	4090
25 km/h	1720	1885	2050	2145	2235	2330	2420	2530	2640	2750	2860	2940	3020		
25 km/h Cyc	1890	2075	2260	2360	2460	2560	2660	2780	2900	3020	3140	3230	3320		
30 km/h	1660	1820	1980	2070	2155	2245	2330	2440	2545	2655	2760	2840	2920		
30 km/h Cyc	1770	1940	2110	2205	2300	2395	2490	2605	2715	2830	2940	3025	3110		
50 km/h	1550	1700	1850	1935	2015	2100	2180	2280	2380	2475	2575	2650	2725		

Ø pouces	Description	CAI	e mm	D mm	R' mm	Cdr. mm	Jante(s) recommandée(s)		Jante(s) tolérée(s)	Chambre à air (Code)	Volume interne 75% (litres)	Profond. de sculpture (mm)			
42	320/90R42 147A8/147B TL	425361	312	1638	764	4908	DW10L		W10L W9L		197	42			
Bar	1.2	1.4	1.6	1.8	2	2.2	2.4	2.6	2.8	3	3.2	3.4	3.6	3.8	4
Psi	17	20	23	26	29	32	35	38	41	44	46	49	52	55	58
10 km/h Cyc			2850	3025	3195	3370	3540	3650	3760	3865	3975	4165	4350	4480	4610
25 km/h	1890	2090	2290	2395	2495	2600	2700	2830	2960	3090	3220	3320	3415		
25 km/h Cyc	2075	2295	2510	2625	2740	2850	2965	3110	3255	3395	3540	3645	3750		
30 km/h	1820	2010	2200	2300	2400	2500	2600	2725	2850	2975	3100	3195	3290		
30 km/h Cyc	1940	2225	2510	2575	2640	2705	2770	2905	3040	3170	3305	3405	3505		
50 km/h	1700	1880	2060	2155	2245	2340	2430	2550	2665	2785	2900	2990	3075		

* Se référer aux remarques en fin des tableaux de cette gamme

MICHELIN AGRIBIB ROW CROP

Caractéristiques & Pression en bar / psi – Charges par pneu en kg*

Ø pouces	Description	CAI	e mm	D mm	R' mm	Cdr. mm	Jante(s) recommandée(s)		Jante(s) tolérée(s)	Chambre à air (Code)	Volume interne 75% (litres)	Profond. de sculpture (mm)			
46	340/85R46 150A8/150B TL	846786	338	1747	810	5227	W12		DW10A W10 W12A	835	225	41			
Bar	1.2	1.4	1.6	1.8	2	2.2	2.4	2.6	2.8	3	3.2	3.4	3.6	3.8	4
Psi	17	20	23	26	29	32	35	38	41	44	46	49	52	55	58
10 km/h Cyc			2780	3025	3265	3510	3750	3900	4050	4200	4350	4540	4730	4880	5030
25 km/h	2050	2270	2490	2605	2715	2830	2940	3080	3220	3360	3500	3610	3720		
25 km/h Cyc	2260	2495	2730	2855	2980	3105	3230	3385	3535	3690	3840	3965	4090		
30 km/h	1980	2190	2400	2510	2620	2730	2840	2975	3105	3240	3370	3475	3580		
30 km/h Cyc	2110	2330	2550	2670	2785	2905	3020	3165	3305	3450	3590	3705	3820		
50 km/h	1850	2045	2240	2345	2445	2550	2650	2775	2900	3025	3150	3250	3350		

Ø pouces	Description	CAI	e mm	D mm	R' mm	Cdr. mm	Jante(s) recommandée(s)		Jante(s) tolérée(s)	Chambre à air (Code)	Volume interne 75% (litres)	Profond. de sculpture (mm)			
46	IF 380/90R46 165A8/165B TL	120462	382	1844	852	5513	DW13A		DW12A W12A W12 DW13 W13A W13	835	308	48			
Bar	1.2	1.4	1.6	1.8	2	2.2	2.4	2.6	2.8	3	3.2	3.4	3.6	3.8	4
Psi	17	20	23	26	29	32	35	38	41	44	46	49	52	55	58
10 km/h	3000	3340	3675	3850	4025	4150	4275	4475	4675	4890	5100	5240	5375	5525	5675
20 km/h	2950	3290	3625	3790	3950	4065	4175	4390	4600	4800	5000	5140	5275	5415	5550
30 km/h	2825	3150	3475	3640	3800	3915	4025	4225	4425	4615	4800	4940	5075	5215	5350
50 km/h	2725	3040	3350	3500	3650	3765	3875	4065	4250	4440	4625	4750	4875	5015	5150

Ø pouces	Description	CAI	e mm	D mm	R' mm	Cdr. mm	Jante(s) recommandée(s)		Jante(s) tolérée(s)	Chambre à air (Code)	Volume interne 75% (litres)	Profond. de sculpture (mm)			
46	380/90R46 157A8/157B TL	799905	401	1864	867	5583	W13A		W12A W12 DW13A DW13 W13	835	308	46			
Bar	1.2	1.4	1.6	1.8	2	2.2	2.4	2.6	2.8	3	3.2	3.4	3.6	3.8	4
Psi	17	20	23	26	29	32	35	38	41	44	46	49	52	55	58
10 km/h Cyc			3450	3740	4030	4320	4610	4790	4970	5150	5330	5570	5810	6000	6190
25 km/h	2550	2830	3110	3235	3360	3485	3610	3785	3955	4130	4300	4440	4580		
25 km/h Cyc	2810	3115	3420	3560	3695	3835	3970	4160	4350	4540	4730	4880	5030		
30 km/h	2460	2730	3000	3120	3240	3360	3480	3650	3815	3985	4150	4280	4410		
30 km/h Cyc	2620	2905	3190	3320	3450	3580	3710	3890	4065	4245	4420	4560	4700		
50 km/h	2300	2550	2800	2915	3025	3140	3250	3405	3565	3720	3875	4000	4125		

* Se référer aux remarques en fin des tableaux de cette gamme

MICHELIN AGRIBIB ROW CROP

Caractéristiques & Pression en bar / psi – Charges par pneu en kg*

Ø pouces	Description	CAI	e mm	D mm	R' mm	Cdr. mm	Jante(s) recommandée(s)	Jante(s) tolérée(s)	Chambre à air (Code)	Volume interne 75% (litres)	Profond. de sculpture (mm)				
50	320/90R50 150A8/150B TL	130813	314	1847	862	5539	W10	DW10A W10A	816	226	39				
Bar	1.2	1.4	1.6	1.8	2	2.2	2.4	2.6	2.8	3	3.2	3.4	3.6	3.8	4
Psi	17	20	23	26	29	32	35	38	41	44	46	49	52	55	58
10 km/h Cyc		2780	3025	3265	3510	3750	3900	4050	4200	4350	4540	4730	4880	5030	
25 km/h	2050	2270	2490	2605	2715	2830	2940	3080	3220	3360	3500	3610	3720		
25 km/h Cyc	2260	2495	2730	2855	2980	3105	3230	3385	3535	3690	3840	3965	4090		
30 km/h	1980	2190	2400	2510	2620	2730	2840	2975	3105	3240	3370	3475	3580		
30 km/h Cyc	2110	2330	2550	2670	2785	2905	3020	3165	3305	3450	3590	3705	3820		
50 km/h	1850	2045	2240	2345	2445	2550	2650	2775	2900	3025	3150	3250	3350		

Ø pouces	Description	CAI	e mm	D mm	R' mm	Cdr. mm	Jante(s) recommandée(s)	Jante(s) tolérée(s)	Chambre à air (Code)	Volume interne 75% (litres)	Profond. de sculpture (mm)				
50	IF 320/90R50 158A8/158B TL	125798	322	1849	865	5544	DW11	DW10A W10A W10 W11		226	42				
Bar	1.2	1.4	1.6	1.8	2	2.2	2.4	2.6	2.8	3	3.2	3.4	3.6	3.8	4
Psi	17	20	23	26	29	32	35	38	41	44	46	49	52	55	58
10 km/h	2450	2725	3000	3140	3275	3390	3500	3665	3825	3975	4125	4265	4400	4540	4675
20 km/h	2400	2665	2925	3075	3225	3325	3425	3590	3750	3900	4050	4190	4325	4465	4600
30 km/h	2300	2565	2825	2965	3100	3200	3300	3465	3625	3765	3900	4025	4150	4290	4425
50 km/h	2225	2475	2725	2850	2975	3075	3175	3325	3475	3615	3750	3875	4000	4125	4250

Ø pouces	Description	CAI	e mm	D mm	R' mm	Cdr. mm	Jante(s) recommandée(s)	Jante(s) tolérée(s)	Chambre à air (Code)	Volume interne 75% (litres)	Profond. de sculpture (mm)
50	380/90R50 151A8/151B TL	036849	393	1935	912	5813	DW13A	DW12A W12A W13A		329	47
Bar	1.2	1.4	1.6	1.8	2	2.2	2.4	2.6	2.8		
Psi	17	20	23	26	29	32	35	38	41		
10 km/h Cyc		3540	3945	4350	4555	4765	4970	5175			
25 km/h	2620	2920	3220	3375	3525	3680	3830				
25 km/h Cyc	2880	3210	3540	3710	3875	4045	4210				
30 km/h	2525	2815	3100	3250	3395	3545	3690				
30 km/h Cyc	2690	3000	3305	3465	3620	3780	3935				
50 km/h	2360	2630	2900	3040	3175	3315	3450				

* Se référer aux remarques en fin des tableaux de cette gamme

MICHELIN AGRIBIB ROW CROP

Caractéristiques & Pression en bar / psi – Charges par pneu en kg*

Ø pouces	Description	CAI	e mm	D mm	R' mm	Cdr. mm	Jante(s) recommandée(s)		Jante(s) tolérée(s)	Chambre à air (Code)	Volume interne 75% (litres)	Profond. de sculpture (mm)			
50	IF 380/90R50 167A8/167B TL NEW	212359	395	1953	903	5841	DW13A		DW12A W12A W13A		329	47			
Bar	1.2	1.4	1.6	1.8	2	2.2	2.4	2.6	2.8	3	3.2	3.4	3.6	3.8	4
Psi	17	20	23	26	29	32	35	38	41	44	46	49	52	55	58
10 km/h	3200	3500	3800	4040	4275	4415	4550	4750	4950	5165	5375	5525	5675	5840	6000
20 km/h	3125	3425	3725	3950	4175	4315	4450	4650	4850	5065	5275	5415	5550	5715	5875
30 km/h	3025	3315	3600	3815	4025	4165	4300	4490	4675	4875	5075	5215	5350	5515	5675
50 km/h	2900	3175	3450	3665	3875	4000	4125	4315	4500	4690	4875	5015	5150	5300	5450

Ø pouces	Description	CAI	e mm	D mm	R' mm	Cdr. mm	Jante(s) recommandée(s)		Jante(s) tolérée(s)	Chambre à air (Code)	Volume interne 75% (litres)	Profond. de sculpture (mm)			
54	IF 320/90R54 159A8/159B TL	467712	322	1949	915	5848	DW11		DW10 W10 W11		240	42			
Bar	1.2	1.4	1.6	1.8	2	2.2	2.4	2.6	2.8	3	3.2	3.4	3.6	3.8	4
Psi	17	20	23	26	29	32	35	38	41	44	46	49	52	55	58
10 km/h	2550	2840	3125	3275	3425	3540	3650	3825	4000	4150	4300	4450	4600	4715	4825
20 km/h	2500	2775	3050	3200	3350	3465	3575	3750	3925	4075	4225	4365	4500	4615	4725
30 km/h	2400	2675	2950	3090	3225	3340	3450	3615	3775	3925	4075	4215	4350	4450	4550
50 km/h	2325	2575	2825	2965	3100	3215	3325	3475	3625	3775	3925	4050	4175	4275	4375

Ø pouces	Description	CAI	e mm	D mm	R' mm	Cdr. mm	Jante(s) recommandée(s)		Jante(s) tolérée(s)	Chambre à air (Code)	Volume interne 75% (litres)	Profond. de sculpture (mm)			
54	320/90R54 151A8/151B TL	272304	315	1950	915	5852	W10		DW11 W11	816	240	39			
Bar	1.2	1.4	1.6	1.8	2	2.2	2.4	2.6	2.8	3	3.2	3.4	3.6	3.8	4
Psi	17	20	23	26	29	32	35	38	41	44	46	49	52	55	58
10 km/h Cyc			2930	3165	3395	3630	3860	4020	4180	4340	4500	4690	4880	5030	5180
25 km/h	2160	2390	2620	2720	2820	2920	3020	3170	3315	3465	3610	3720	3830		
25 km/h Cyc	2380	2630	2880	2990	3100	3210	3320	3485	3645	3810	3970	4090	4210		
30 km/h	2090	2310	2530	2630	2725	2825	2920	3060	3200	3340	3480	3585	3690		
30 km/h Cyc	2220	2455	2690	2795	2900	3005	3110	3260	3410	3560	3710	3820	3930		
50 km/h	1950	2155	2360	2450	2545	2635	2725	2855	2990	3120	3250	3350	3450		

***REMARQUES**

La pression de gonflage se détermine toujours en fonction de la charge par pneu, de la vitesse et du travail à réaliser.

Nos préconisations ci-dessus sont fournies sous réserve de modifications postérieures à la date de diffusion de ces tableaux (mars 2021).

Les données techniques sont susceptibles d'évoluer sans information préalable.

- Pour usage en dévers >20% : ajouter 0,4 bar.
- Pour usage routier intensif >50% : ajouter 0,4 bar.
- 10, 25 ou 30 km/h Cyc: Utilisation champ uniquement, déplacement à pleine charge cyclique sur une distance de 1,5km maximum

**NOUVEAU**

MICHELIN TRAILXBIB

LA LONGÉVITÉ SANS COMPROMIS POUR VOS PNEUS REMORQUES



TECHNOLOGIE VF MICHELIN ULTRAFLEX

- Respect des sols grâce à un travail à basse pression
- Productivité augmentée



ENDURANCE AMÉLIORÉE

- Nouvelle carcasse VF pour une plus grande robustesse et une meilleure résistance à basse pression
- Nappes sommet métalliques



AUTO-NETTOYAGE

- Sculpture à barrettes incurvées, facilitant l'évacuation de la terre
- Inter-barrettes larges et divergentes



DURÉE DE VIE OPTIMISÉE

- Angle de dépouille important limitant les phénomènes de cassures à l'épaule
- Davantage de gomme à user



COMPORTEMENT ROUTIER

- RIB central pour améliorer le comportement routier



DIMENSIONS

VF 600/50R22.5 IMP 164D TL **NEW**VF 500/60R22.5 IMP 160D TL **NEW**VF 710/45R22.5 IMP 170D TL **NEW**VF 560/60R22.5 IMP 166D TL **NEW**VF 600/55R26.5 IMP 170D TL **NEW**VF 710/50R26.5 IMP 176D TL **NEW**VF 650/55R26.5 IMP 174D TL **NEW**VF 650/65R30.5 IMP 181D TL **NEW**VF 750/60R30.5 IMP 187D TL **NEW**

MICHELIN TRAILXBIB

Caractéristiques & Pression en bar / psi – Charges par pneu en kg*

Ø pouces	Description	CAI	e mm	D mm	R' mm	Cdt mm	Jante(s) recommandée(s)	Jante(s) tolérée(s)	Chambre à air (Code)	Volume interne 75% (litres)	Profond. de sculpture (mm)
22.5	VF 600/50R22.5 IMP 164D TL NEW	414979	617	1172	485	3419	AG20.00 (H2)			247	18
Bar	0.9 1 1.2 1.8 2.1 2.4 2.7 3										
Psi	13 15 17 26 30 35 39 44										
10 km/h	3740	4005	4530	5830	6340	6845	7355	7860			
25 km/h	3335	3570	4045	5200	5650	6100	6550	7000			
40 km/h	2935	3145	3570	4595	4995	5390	5790	6185			
50 km/h	2665	2855	3230	4160	4525	4885	5245	5610			
65 km/h	2285	2445	2770	3560	3870	4175	4485	4795			

Ø pouces	Description	CAI	e mm	D mm	R' mm	Cdt mm	Jante(s) recommandée(s)	Jante(s) tolérée(s)	Chambre à air (Code)	Volume interne 75% (litres)	Profond. de sculpture (mm)
22.5	VF 500/60R22.5 IMP 160D TL NEW	229116	501	1173	493	3433	AG16.00 (H2)	16.00 15.00 17.00		206	19.5
Bar	0.8 0.9 1 1.2 1.5 1.8 2.1 2.4 2.7 3 3.2										
Psi	12 13 15 17 22 26 30 35 39 44 46										
10 km/h	3125	3335	3545	3970	4600	5090	5580	6070 6560	7050	7375	
25 km/h	2775	2965	3155	3530	4100	4535	4975	5410 5845	6285	6575	
40 km/h	2450	2615	2780	3105	3600	3990	4375	4765 5155	5540	5800	
50 km/h	2225	2375	2525	2825	3275	3630	3980	4335 4685	5040	5275	
65 km/h	1900	2030	2155	2415	2800	3100	3400	3700 4000	4300	4500	

Ø pouces	Description	CAI	e mm	D mm	R' mm	Cdt mm	Jante(s) recommandée(s)	Jante(s) tolérée(s)	Chambre à air (Code)	Volume interne 75% (litres)	Profond. de sculpture (mm)
22.5	VF 710/45R22.5 IMP 170D TL NEW	520302	717	1214	519	3562				317	20.5
Bar	0.8 0.9 1 1.2 1.5 1.8 2.1 2.4 2.7 3 3.2										
Psi	12 13 15 17 22 26 30 35 39 44 46										
10 km/h	4225	4500	4775	5325	6250	7175	7590	8000 8695	9390	9850	
25 km/h	3750	4000	4250	4750	5575	6400	6765	7125 7735	8345	8750	
40 km/h	3325	3545	3765	4200	4925	5650	5975	6300 6845	7390	7750	
50 km/h	3025	3220	3415	3800	4465	5125	5415	5700 6195	6695	7025	
65 km/h	2575	2745	2915	3250	3815	4375	4625	4875 5295	5720	6000	

* Se référer aux remarques en fin des tableaux de cette gamme

MICHELIN TRAILXBIB

Caractéristiques & Pression en bar / psi – Charges par pneu en kg*

Ø pouces	Description	CAI	e mm	D mm	R' mm	Cdr mm	Jante(s) recommandée(s)		Jante(s) tolérée(s)	Chambre à air (Code)	Volume interne 75% (litres)	Profond. de sculpture (mm)
22.5	VF 560/60R22.5 IMP 166D TL NEW	103824	542	1242	507	3612	AG16.00 (H2)		16.00 AG20.00 (H2) 17.00 AG18.00		263	19
							Bar	0.8	0.9			

Ø pouces	Description	CAI	e mm	D mm	R' mm	Cdr mm	Jante(s) recommandée(s)		Jante(s) tolérée(s)	Chambre à air (Code)	Volume interne 75% (litres)	Profond. de sculpture (mm)
26.5	VF 600/55R26.5 IMP 170D TL NEW	112743	624	1353	568	3960	AG20.00 (H2)				312	22
							Bar	0.8	0.9			

Ø pouces	Description	CAI	e mm	D mm	R' mm	Cdr mm	Jante(s) recommandée(s)		Jante(s) tolérée(s)	Chambre à air (Code)	Volume interne 75% (litres)	Profond. de sculpture (mm)
26.5	VF 710/50R26.5 IMP 176D TL NEW	723409	739	1380	568	4022	AG24.00 (H2)				407	22
							Bar	0.8	0.9			

* Se référer aux remarques en fin des tableaux de cette gamme

MICHELIN TRAILXBIB

Caractéristiques & Pression en bar / psi – Charges par pneu en kg*

Ø pouces	Description	CAI	e mm	D mm	R' mm	Cdr mm	Jante(s) recommandée(s)		Jante(s) tolérée(s)	Chambre à air (Code)	Volume interne 75% (litres)	Profond. de sculpture (mm)
26.5	VF 650/55R26.5 IMP 174D TL NEW	054878	649	1402	575	4082	AG20.00 (H2)				377	23
Bar	0.8	0.9	1	1.2	1.5	1.8	2.1	2.4	2.7	3	3.2	
Psi	12	13	15	17	22	26	30	35	39	44	46	
10 km/h	4225	4570	4920	5495	6355	7175	8020	8940	9800	10660	10990	
25 km/h	3760	4070	4380	4890	5660	6390	7140	7955	8725	9490	9780	
40 km/h	3320	3595	3870	4320	5000	5645	6310	7030	7710	8385	8645	
50 km/h	3015	3260	3510	3920	4535	5120	5720	6375	6990	7605	7840	
65 km/h	2575	2770	2965	3350	3875	4325	4830	5450	5975	6500	6700	

Ø pouces	Description	CAI	e mm	D mm	R' mm	Cdr mm	Jante(s) recommandée(s)		Jante(s) tolérée(s)	Chambre à air (Code)	Volume interne 75% (litres)	Profond. de sculpture (mm)
30.5	VF 650/65R30.5 IMP 181D TL NEW	120737	668	1624	699	4778	AG20.00 (H2)				518	27
Bar	0.8	0.9	1	1.2	1.5	1.8	2.1	2.4	2.7	3	3.2	
Psi	12	13	15	17	22	26	30	35	39	44	46	
10 km/h	5650	6030	6415	7175	8065	8950	9975	11000	11945	12895	13525	
25 km/h	5025	5370	5715	6400	7175	7950	8865	9775	10630	11480	12050	
40 km/h	4450	4750	5050	5650	6340	7025	7840	8650	9400	10150	10650	
50 km/h	4025	4300	4575	5125	5750	6375	7115	7850	8525	9200	9650	
65 km/h	3450	3680	3915	4375	4915	5450	6075	6700	7280	7865	8250	

Ø pouces	Description	CAI	e mm	D mm	R' mm	Cdr mm	Jante(s) recommandée(s)		Jante(s) tolérée(s)	Chambre à air (Code)	Volume interne 75% (litres)	Profond. de sculpture (mm)
30.5	VF 750/60R30.5 IMP 187D TL NEW	223428	780	1669	695	4873	AG24.00 (H2)		AG24.00		650	27
Bar	0.8	0.9	1	1.2	1.5	1.8	2.1	2.4	2.7	3	3.2	
Psi	12	13	15	17	22	26	30	35	39	44	46	
10 km/h	6350	6815	7275	8200	9265	10325	11515	12700	13940	15175	16000	
25 km/h	5650	6065	6475	7300	8250	9200	10265	11325	12415	13500	14225	
40 km/h	5000	5365	5725	6450	7290	8125	9065	10000	10965	11930	12575	
50 km/h	4525	4855	5190	5850	6615	7375	8225	9075	9945	10820	11400	
65 km/h	3875	4155	4440	5000	5650	6300	7025	7750	8500	9250	9750	

***REMARQUES**

La pression de gonflage se détermine toujours en fonction de la charge par pneu, de la vitesse et du travail à réaliser.

Nos préconisations ci-dessus sont fournies sous réserve de modifications postérieures à la date de diffusion de ces tableaux (mars 2021).

Les données techniques sont susceptibles d'évoluer sans information préalable.

- Pour usage en dévers >20% : ajouter 0,4 bar.
- Pour usage routier intensif >50% : ajouter 0,4 bar.



MICHELIN CARGOXBIB HIGH FLOTATION

**LE PNEU DE REMORQUE
QUI RESPECTE VOS SOLS**



La meilleure performance **de la route aux champs**



PROTECTION DES SOLS

Grâce à une basse pression à partir de 0,8 bar et à une surface au sol de +37%⁽¹⁾



Jusqu'à 3 fois plus de **pouvoir auto-nettoyant** que l'ancienne gamme CARGOXBIB⁽¹⁾



Excellente **maniabilité sur la route**

(1) Études internes au Centre Technologique Michelin Avril 2011 / Juin 2013

DIMENSIONS

710/45R22.5 165D TL

28LR26 175D TL

600/55R26.5 165D TL

VF 600/55R26.5 IMP 170D TL

710/50R26.5 170D TL

VF 710/50R26.5 IMP 176D TL

650/55R26.5 169D TL

VF 650/55R26.5 IMP 174D TL

650/65R30.5 176D TL

VF 750/60R30.5 IMP 187D TL

750/60R30.5 181D TL

800/60R32 IMP 185D TL

MICHELIN CARGOXBIB HIGH FLOTATION

Caractéristiques & Pression en bar / psi – Charges par pneu en kg*

Ø pouces	Description	CAI	e mm	D mm	R' mm	Cdr mm	Jante(s) recommandée(s)		Jante(s) tolérée(s)		Chambre à air (Code)	Volume interne 75% (litres)	Profond. de sculpture (mm)		
22.5	710/45R22.5 16SD TL	723051	723	1208	514	3545	AG24.00 (H2)		AG20.00 (H2)			317	16		
Bar	0.8	0.9	1	1.2	1.5	1.8	2.1	2.4	2.7	3	3.2	3.4	3.6	3.8	4
Psi	12	13	15	17	22	26	30	35	39	44	46	49	52	55	58
10 km/h	2970	3430	3890	4325	4970	5620	6270	6920	7360	7800	8095	8390	8685	8975	9270
25 km/h	2610	2930	3250	3650	4255	4855	5460	6060	6450	6840	7100	7360	7620	7880	8140
40 km/h	2250	2525	2800	3145	3665	4185	4700	5220	5555	5890	6110	6335	6555	6780	7000
50 km/h	2000	2245	2490	2795	3260	3720	4180	4640	4940	5235	5435	5635	5835	6030	6230
65 km/h	1650	1855	2060	2315	2695	3075	3460	3840	4085	4330	4495	4660	4825	4985	5150

Ø pouces	Description	CAI	e mm	D mm	R' mm	Cdr mm	Jante(s) recommandée(s)		Jante(s) tolérée(s)		Chambre à air (Code)	Volume interne 75% (litres)	Profond. de sculpture (mm)		
26	28LR26 17SD TL	224829	740	1581	705	4685	DW25B (A)		DW23B(A)			578	26		
Bar	0.8	0.9	1	1.2	1.5	1.8	2.1	2.4	2.7	3	3.2	3.4	3.6	3.8	4
Psi	12	13	15	17	22	26	30	35	39	44	46	49	52	55	58
15 km/h	3750	3935	4120	4615	5360	5905	6460	7035	7605	7905	8140	8375	8710	8980	9245
25 km/h	3320	3485	3645	4085	4740	5220	5710	6220	6725	6990	7200	7405	7705	7940	8175
40 km/h	3065	3215	3365	3770	4380	4825	5280	5750	6215	6460	6655	6845	7120	7340	7555
50 km/h	2940	3085	3230	3620	4200	4625	5060	5515	5960	6195	6380	6565	6825	7035	7245
65 km/h	2800	2940	3075	3445	4000	4405	4820	5250	5675	5900	6075	6250	6500	6700	6900

Ø pouces	Description	CAI	e mm	D mm	R' mm	Cdr mm	Jante(s) recommandée(s)		Jante(s) tolérée(s)		Chambre à air (Code)	Volume interne 75% (litres)	Profond. de sculpture (mm)		
26.5	600/55R26.5 16SD TL	550621	626	1341	581	3954	AG20.00 (H2)				716	312	17		
Bar	0.8	0.9	1	1.2	1.5	1.8	2.1	2.4	2.7	3	3.2	3.4	3.6	3.8	4
Psi	12	13	15	17	22	26	30	35	39	44	46	49	52	55	58
10 km/h	2970	3585	4200	4675	5380	6090	6800	7510	7840	8170	8390	8610	8830	9050	9270
25 km/h	2610	3085	3560	3995	4640	5290	5940	6590	6880	7170	7365	7560	7755	7945	8140
40 km/h	2250	2675	3100	3465	4020	4570	5120	5670	5920	6170	6335	6500	6670	6835	7000
50 km/h	2000	2375	2750	3080	3570	4065	4555	5050	5270	5495	5640	5790	5935	6085	6230
65 km/h	1650	1975	2300	2565	2970	3370	3770	4170	4355	4540	4660	4785	4905	5030	5150

* Se référer aux remarques en fin des tableaux de cette gamme

MICHELIN CARGOXBIB HIGH FLOTATION

Caractéristiques & Pression en bar / psi – Charges par pneu en kg*

Ø pouces	Description	CAI	e mm	D mm	R' mm	Cdr. mm	Jante(s) recommandée(s)	Jante(s) tolérée(s)	Chambre à air (Code)	Volume interne 75% (litres)	Profond. de sculpture (mm)
26.5	VF 600/55R26.5 IMP 170D TL	377726	626	1341	562	3923	AG20.00 (H2)			312	17
Bar	0.8	0.9	1	1.2	1.5	1.8	2.1	2.4	2.7	3	3.2
Psi	12	13	15	17	22	26	30	35	39	44	46
10 km/h	3770	4025	4265	4755	5660	6320	7080	7790	8550	9185	9840
25 km/h	3360	3585	3795	4235	5035	5630	6305	6935	7610	8175	8760
40 km/h	2965	3165	3355	3740	4450	4975	5570	6130	6725	7225	7740
50 km/h	2690	2870	3040	3395	4035	4510	5050	5560	6100	6550	7020
65 km/h	2300	2450	2600	2900	3450	3855	4280	4750	5275	5600	6000

Ø pouces	Description	CAI	e mm	D mm	R' mm	Cdr. mm	Jante(s) recommandée(s)	Jante(s) tolérée(s)	Chambre à air (Code)	Volume interne 75% (litres)	Profond. de sculpture (mm)				
26.5	710/50R26.5 170D TL	892516	729	1380	594	4061	AG24.00 (H2)	AG20.00 (H2)		407	18				
Bar	0.8	0.9	1	1.2	1.5	1.8	2.1	2.4	2.7	3	3.2	3.4	3.6	3.8	4
Psi	12	13	15	17	22	26	30	35	39	44	46	49	52	55	58
10 km/h	3510	4205	4900	5450	6275	7100	7925	8750	9135	9520	9775	10030	10290	10545	10800
25 km/h	3080	3610	4140	4645	5400	6155	6915	7670	8010	8350	8575	8800	9030	9255	9480
40 km/h	2650	3130	3610	4040	4680	5325	5965	6610	6900	7190	7385	7580	7775	7965	8160
50 km/h	2360	2780	3200	3585	4155	4730	5305	5880	6140	6400	6570	6745	6915	7090	7260
65 km/h	1950	2315	2680	2990	3460	3925	4395	4860	5075	5290	5430	5575	5715	5860	6000

Ø pouces	Description	CAI	e mm	D mm	R' mm	Cdr. mm	Jante(s) recommandée(s)	Jante(s) tolérée(s)	Chambre à air (Code)	Volume interne 75% (litres)	Profond. de sculpture (mm)
26.5	VF 710/50R26.5 IMP 176D TL	343405	729	1380	568	4022	AG24.00 (H2)	AG20.00 (H2)		407	18
Bar	0.8	0.9	1	1.2	1.5	1.8	2.1	2.4	2.7	3	3.2
Psi	12	13	15	17	22	26	30	35	39	44	46
10 km/h	4470	4770	5150	5820	6765	7505	8400	9185	10080	10990	11645
25 km/h	3980	4245	4585	5185	6025	6680	7480	8175	8975	9780	10365
40 km/h	3515	3750	4050	4580	5320	5900	6605	7225	7930	8645	9160
50 km/h	3190	3400	3675	4155	4825	5355	5995	6550	7190	7840	8305
65 km/h	2725	2930	3140	3550	4125	4575	5055	5600	6275	6700	7100

* Se référer aux remarques en fin des tableaux de cette gamme

MICHELIN CARGOXBIB HIGH FLOTATION

Caractéristiques & Pression en bar / psi – Charges par pneu en kg*

Ø pouces	Description	CAI	e mm	D mm	R' mm	Cdr mm	Jante(s) recommandée(s)		Jante(s) tolérée(s)	Chambre à air (Code)	Volume interne 75% (litres)	Profond. de sculpture (mm)			
26.5	650/55R26.5 169D TL	693431	657	1402	617	4158	AG20.00 (H2)			716	437	18			
Bar	0.8	0.9	1	1.2	1.5	1.8	2.1	2.4	2.7	3	3.2	3.4	3.6	3.8	4
Psi	12	13	15	17	22	26	30	35	39	44	46	49	52	55	58
10 km/h	3330	3985	4635	5220	6100	6875	7600	8325	8780	9235	9540	9765	9990	10215	10440
25 km/h	2925	3500	4070	4585	5355	6035	6675	7310	7710	8110	8375	8575	8770	8970	9165
40 km/h	2515	3010	3500	3945	4610	5195	5745	6290	6635	6980	7210	7380	7550	7720	7890
50 km/h	2240	2680	3115	3510	4100	4620	5110	5595	5905	6210	6415	6565	6720	6870	7020
65 km/h	1850	2215	2575	2900	3390	3820	4220	4625	4880	5130	5300	5425	5550	5675	5800

Ø pouces	Description	CAI	e mm	D mm	R' mm	Cdr mm	Jante(s) recommandée(s)		Jante(s) tolérée(s)	Chambre à air (Code)	Volume interne 75% (litres)	Profond. de sculpture (mm)
26.5	VF 650/55R26.5 IMP 174D TL	776393	663	1402	578	4084	AG20.00		AG20.00 (H2)		437	18
Bar	0.8	0.9	1	1.2	1.5	1.8	2.1	2.4	2.7	3	3.2	
Psi	12	13	15	17	22	26	30	35	39	44	46	
10 km/h	4225	4570	4920	5495	6355	7175	8020	8940	9800	10660	10990	
25 km/h	3760	4070	4380	4890	5660	6390	7140	7955	8725	9490	9780	
40 km/h	3320	3595	3870	4320	5000	5645	6310	7030	7710	8385	8645	
50 km/h	3015	3260	3510	3920	4535	5120	5720	6375	6990	7605	7840	
65 km/h	2575	2770	2965	3350	3875	4325	4830	5450	5975	6500	6700	

Ø pouces	Description	CAI	e mm	D mm	R' mm	Cdr mm	Jante(s) recommandée(s)		Jante(s) tolérée(s)	Chambre à air (Code)	Volume interne 75% (litres)	Profond. de sculpture (mm)			
30.5	650/65R30.5 176D TL	139310	674	1622	699	4776	AG20.00 (H2)				600	21			
Bar	0.8	0.9	1	1.2	1.5	1.8	2.1	2.4	2.7	3	3.2	3.4	3.6	3.8	4
Psi	12	13	15	17	22	26	30	35	39	44	46	49	52	55	58
10 km/h	4140	4970	5800	6450	7430	8405	9385	10360	10815	11270	11570	11875	12175	12480	12780
25 km/h	3640	4270	4900	5495	6395	7290	8185	9080	9480	9885	10150	10420	10685	10955	11220
40 km/h	3130	3705	4280	4785	5545	6305	7060	7820	8165	8510	8740	8970	9200	9430	9660
50 km/h	2780	3285	3790	4245	4920	5600	6280	6960	7265	7570	7775	7980	8185	8385	8590
65 km/h	2300	2735	3170	3540	4090	4645	5195	5750	6005	6255	6425	6595	6765	6930	7100

* Se référer aux remarques en fin des tableaux de cette gamme

MICHELIN CARGOXBIB HIGH FLOTATION

Caractéristiques & Pression en bar / psi – Charges par pneu en kg*

Ø pouces	Description	CAI	e mm	D mm	R' mm	Cdr mm	Jante(s) recommandée(s)		Jante(s) tolérée(s)	Chambre à air (Code)	Volume interne 75% (litres)	Profond. de sculpture (mm)
30.5	VF 60R30.5 IMP 187D TL	139588	780	1674	687	4875	AG24.00 (H2)				750	21
Bar	0.8	0.9	1	1.2	1.5	1.8	2.1	2.4	2.7	3	3.2	
Psi	12	13	15	17	22	26	30	35	39	44	46	
10 km/h	6150	6560	6970	7790	9020	10250	11480	12710	13940	15170	15990	
25 km/h	5475	5840	6205	6935	8030	9125	10220	11315	12410	13505	14235	
40 km/h	4840	5160	5485	6130	7095	8065	9030	10000	10965	11935	12580	
50 km/h	4390	4680	4975	5560	6435	7315	8190	9070	9945	10825	11410	
65 km/h	3750	4000	4250	4750	5500	6250	7000	7750	8500	9250	9750	

Ø pouces	Description	CAI	e mm	D mm	R' mm	Cdr mm	Jante(s) recommandée(s)		Jante(s) tolérée(s)	Chambre à air (Code)	Volume interne 75% (litres)	Profond. de sculpture (mm)			
30.5	750/60R30.5 181D TL	101332	786	1675	716	4936	AG24.00 (H2)				750	22			
Bar	0.8	0.9	1	1.2	1.5	1.8	2.1	2.4	2.7	3	3.2	3.4	3.6	3.8	4
Psi	12	13	15	17	22	26	30	35	39	44	46	49	52	55	58
10 km/h	4770	5750	6730	7490	8625	9765	10900	12040	12565	13095	13445	13795	14150	14500	14850
25 km/h	4185	4945	5700	6395	7430	8470	9510	10550	11015	11485	11795	12105	12420	12730	13040
40 km/h	3605	4290	4970	5560	6440	7325	8205	9090	9490	9890	10155	10420	10690	10955	11220
50 km/h	3205	3810	4410	4935	5720	6505	7295	8080	8435	8795	9030	9270	9505	9745	9980
65 km/h	2650	3165	3680	4110	4750	5395	6035	6680	6975	7270	7465	7660	7860	8055	8250

Ø pouces	Description	CAI	e mm	D mm	R' mm	Cdr mm	Jante(s) recommandée(s)		Jante(s) tolérée(s)	Chambre à air (Code)	Volume interne 75% (litres)	Profond. de sculpture (mm)			
32	800/60R32 IMP 185D TL	322432	818	1800	777	5300	DW27B (A)		DW25B (A)	831	900	23.5			
Bar	0.8	0.9	1	1.2	1.5	1.8	2.1	2.4	2.7	3	3.2	3.4	3.6	3.8	4
Psi	12	13	15	17	22	26	30	35	39	44	46	49	52	55	58
10 km/h	5400	6525	7650	8580	9975	11205	12355	13500	14345	15190	15750	15975	16200	16425	16650
25 km/h	4740	5730	6715	7530	8755	9835	10845	11850	12590	13330	13825	14025	14220	14420	14615
40 km/h	4080	4930	5780	6485	7540	8470	9335	10200	10840	11475	11900	12070	12240	12410	12580
50 km/h	3630	4390	5145	5770	6710	7535	8305	9075	9645	10210	10590	10740	10895	11045	11195
65 km/h	3000	3625	4250	4765	5540	6225	6865	7500	7970	8440	8750	8875	9000	9125	9250

***REMARQUES**

La pression de gonflage se détermine toujours en fonction de la charge par pneu, de la vitesse et du travail à réaliser.

Nos préconisations ci-dessus sont fournies sous réserve de modifications postérieures à la date de diffusion de ces tableaux (mars 2021).

Les données techniques sont susceptibles d'évoluer sans information préalable.

- Pour usage en dévers >20% : ajouter 0,4 bar.
- Pour usage routier intensif >50% : ajouter 0,4 bar.



MICHELIN CARGOXBIB HEAVY DUTY

**EXCELLENT RAPPORT
QUALITÉ/PRIX POUR
TRANSPORTER VOS
RÉCOLTES**



Jusqu'à 3 fois plus de **pouvoir auto-nettoyant** que l'ancienne gamme CARGOXBIB⁽¹⁾



STABILITÉ
Excellente **maniabilité sur la route**



DURÉE DE VIE
Endurance carcasse éprouvée

(1) Études internes au Centre Technologique Michelin Avril 2011 / Juin 2013

DIMENSIONS

560/45R22.5 152D TL

500/60R22.5 155D TL

560/60R22.5 161D TL

MICHELIN CARGOXBIB HEAVY DUTY

Caractéristiques & Pression en bar / psi – Charges par pneu en kg*

Ø pouces	Description	CAI	e mm	D mm	R' mm	Cdr mm	Jante(s) recommandée(s)		Jante(s) tolérée(s)	Chambre à air (Code)	Volume interne 75% (litres)	Profond. de sculpture (mm)			
22.5	560/45R22.5 152D TL	743789	535	1080	474	3191	AG16.00 (H2)				182	16			
Bar	0.8	0.9	1	1.2	1.5	1.8	2.1	2.4	2.7	3	3.2	3.4	3.6	3.8	4
Psi	12	13	15	17	22	26	30	35	39	44	46	49	52	55	58
10 km/h	2070	2225	2375	2665	3095	3475	3845	4245	4650	5050	5320	5585	5855	6120	6390
25 km/h	1820	1955	2085	2340	2720	3050	3375	3725	4080	4435	4670	4905	5140	5375	5610
40 km/h	1565	1680	1795	2015	2340	2625	2900	3205	3510	3815	4020	4220	4425	4625	4830
50 km/h	1390	1495	1600	1795	2085	2340	2585	2855	3125	3400	3580	3760	3940	4120	4300
65 km/h	1150	1235	1320	1480	1720	1930	2135	2360	2580	2805	2955	3105	3250	3400	3550

Ø pouces	Description	CAI	e mm	D mm	R' mm	Cdr mm	Jante(s) recommandée(s)		Jante(s) tolérée(s)	Chambre à air (Code)	Volume interne 75% (litres)	Profond. de sculpture (mm)			
22.5	500/60R22.5 155D TL	441880	505	1172	508	3454	AG16.00 (H2)		16.00 14.00 15.00 17.00		206	16			
Bar	0.8	0.9	1	1.2	1.5	1.8	2.1	2.4	2.7	3	3.2	3.4	3.6	3.8	4
Psi	12	13	15	17	22	26	30	35	39	44	46	49	52	55	58
10 km/h	2250	2705	3160	3515	4050	4585	5115	5650	5900	6150	6315	6480	6650	6815	6980
25 km/h	1975	2330	2680	3005	3495	3985	4470	4960	5180	5395	5540	5685	5830	5975	6120
40 km/h	1700	2015	2330	2605	3025	3440	3855	4270	4460	4645	4770	4895	5020	5145	5270
50 km/h	1510	1790	2070	2315	2690	3060	3430	3800	3965	4135	4245	4355	4470	4580	4690
65 km/h	1250	1490	1730	1930	2235	2535	2840	3140	3280	3420	3510	3605	3695	3790	3880

Ø pouces	Description	CAI	e mm	D mm	R' mm	Cdr mm	Jante(s) recommandée(s)		Jante(s) tolérée(s)	Chambre à air (Code)	Volume interne 75% (litres)	Profond. de sculpture (mm)			
22.5	560/60R22.5 161D TL	102433	543	1242	532	3650	AG16.00 (H2)		16.00 AG20.00 (H2) 17.00 AG18.00		269	16			
Bar	0.8	0.9	1	1.2	1.5	1.8	2.1	2.4	2.7	3	3.2	3.4	3.6	3.8	4
Psi	12	13	15	17	22	26	30	35	39	44	46	49	52	55	58
10 km/h	2700	3240	3780	4205	4840	5475	6115	6750	7045	7345	7540	7740	7935	8135	8330
25 km/h	2370	2780	3190	3580	4160	4745	5325	5910	6175	6435	6610	6785	6960	7135	7310
40 km/h	2040	2415	2790	3120	3610	4105	4595	5090	5315	5540	5690	5840	5990	6140	6290
50 km/h	1810	2140	2470	2765	3205	3645	4090	4530	4730	4930	5065	5200	5335	5465	5600
65 km/h	1500	1785	2070	2310	2670	3030	3390	3750	3915	4080	4190	4300	4410	4520	4630

***REMARQUES**

La pression de gonflage se détermine toujours en fonction de la charge par pneu, de la vitesse et du travail à réaliser.

Nos préconisations ci-dessus sont fournies sous réserve de modifications postérieures à la date de diffusion de ces tableaux (mars 2021).

Les données techniques sont susceptibles d'évoluer sans information préalable.

- Pour usage en dévers >20% : ajouter 0,4 bar.
- Pour usage routier intensif >50% : ajouter 0,4 bar.



MICHELIN CARGOXBIB

**ENDURANCE AMÉLIORÉE
POUR DES CHARGES
LOURDES À BASSE
PRESSION**



ENDURANCE



PRODUCTIVITÉ



RENTABILITÉ



DIMENSIONS

600/50R22.5 159D TL

800/45R26.5 174D TL

710/50R30.5 173D TL

800/45R30.5 176D TL

600/60R30.5 169D TL

850/50R30.5 182D TL

MICHELIN CARGOXBIB

Caractéristiques & Pression en bar / psi – Charges par pneu en kg*

Ø pouces	Description	CAI	e mm	D mm	R' mm	Cdr mm	Jante(s) recommandée(s)	Jante(s) tolérée(s)	Chambre à air (Code)	Volume interne 75% (litres)	Profond. de sculpture (mm)
22.5	600/50R22.5 159D TL	048429	616	1181	510	3478	AG20.00 (H2)			298	17
Bar	1	1.3	1.5	1.9	2.2	2.5	2.8	3.1	3.4	3.7	4
Psi	15	19	22	28	32	36	41	45	49	54	58
10 km/h	3570	4170	4575	5375	5980	6475	6755	7035	7320	7600	7880
25 km/h	3020	3570	3940	4670	5225	5675	5920	6170	6415	6665	6910
40 km/h	2640	3105	3420	4040	4510	4890	5105	5315	5525	5740	5950
50 km/h	2340	2760	3035	3595	4010	4355	4540	4730	4915	5105	5290
65 km/h	1950	2290	2520	2970	3315	3595	3750	3910	4065	4225	4380

Ø pouces	Description	CAI	e mm	D mm	R' mm	Cdr mm	Jante(s) recommandée(s)	Jante(s) tolérée(s)	Chambre à air (Code)	Volume interne 75% (litres)	Profond. de sculpture (mm)
26.5	800/45R26.5 174D TL	248959	815	1395	595	4097	AG28.00 (H2)	AG24.00 (H2)		561	19
Bar	1	1.3	1.5	1.9	2.2	2.5	2.8	3.1	3.4	3.7	4
Psi	15	19	22	28	32	36	41	45	49	54	58
10 km/h	5070	5910	6475	7595	8440	9190	9765	10340	10915	11485	12060
25 km/h	4230	5015	5535	6585	7365	8060	8565	9070	9580	10085	10590
40 km/h	3640	4315	4765	5665	6340	6935	7370	7805	8240	8675	9110
50 km/h	3240	3840	4240	5040	5640	6170	6560	6945	7335	7720	8110
65 km/h	2680	3175	3505	4165	4660	5095	5420	5740	6060	6380	6700

Ø pouces	Description	CAI	e mm	D mm	R' mm	Cdr mm	Jante(s) recommandée(s)	Jante(s) tolérée(s)	Chambre à air (Code)	Volume interne 75% (litres)	Profond. de sculpture (mm)
30.5	710/50R30.5 173D TL	002786	728	1495	649	4408	AG24.00 (H2)			537	21
Bar	1	1.3	1.5	1.9	2.2	2.5	2.8	3.1	3.4	3.7	4
Psi	15	19	22	28	32	36	41	45	49	54	58
10 km/h	5310	6205	6800	7990	8885	9620	10035	10450	10870	11285	11700
25 km/h	4490	5310	5855	6945	7765	8435	8800	9170	9535	9905	10270
40 km/h	3910	4605	5070	6000	6695	7265	7580	7895	8210	8525	8840
50 km/h	3470	4090	4505	5335	5955	6465	6745	7025	7310	7590	7870
65 km/h	2900	3410	3745	4425	4930	5345	5580	5810	6040	6270	6500

* Se référer aux remarques en fin des tableaux de cette gamme

MICHELIN CARGOXBIB

Caractéristiques & Pression en bar / psi – Charges par pneu en kg*

Ø pouces	Description	CAI	e mm	D mm	R' mm	Cdr mm	Jante(s) recommandée(s)		Jante(s) tolérée(s)	Chambre à air (Code)	Volume interne 75% (litres)	Profond. de sculpture (mm)
30.5	800/45R30.5 176D TL	932951	820	1495	650	4408	AG28.00 (H2)				616	21
Bar	1	1.3	1.5	1.9	2.2	2.5	2.8	3.1	3.4	3.7	4	
Psi	15	19	22	28	32	36	41	45	49	54	58	
10 km/h	5370	6265	6860	8050	8945	9745	10350	10960	11565	12175	12780	
25 km/h	4490	5320	5870	6980	7805	8540	9075	9610	10150	10685	11220	
40 km/h	3860	4575	5055	6005	6725	7355	7815	8275	8740	9200	9660	
50 km/h	3440	4075	4495	5345	5975	6535	6950	7360	7770	8180	8590	
65 km/h	2840	3365	3715	4415	4940	5405	5745	6080	6420	6760	7100	

Ø pouces	Description	CAI	e mm	D mm	R' mm	Cdr mm	Jante(s) recommandée(s)		Jante(s) tolérée(s)	Chambre à air (Code)	Volume interne 75% (litres)	Profond. de sculpture (mm)
30.5	600/60R30.5 169D TL	236518	639	1496	654	4417	AG20.00 (H2)				469	21
Bar	1	1.3	1.5	1.9	2.2	2.5	2.8	3.1	3.4	3.7	4	
Psi	15	19	22	28	32	36	41	45	49	54	58	
10 km/h	4730	5530	6060	7130	7925	8585	8955	9325	9700	10070	10440	
25 km/h	4000	4735	5220	6200	6930	7530	7855	8180	8510	8835	9160	
40 km/h	3490	4110	4525	5355	5975	6485	6765	7045	7330	7610	7890	
50 km/h	3100	3655	4020	4760	5310	5765	6015	6265	6520	6770	7020	
65 km/h	2590	3040	3345	3945	4400	4770	4975	5180	5390	5595	5800	

Ø pouces	Description	CAI	e mm	D mm	R' mm	Cdr mm	Jante(s) recommandée(s)		Jante(s) tolérée(s)	Chambre à air (Code)	Volume interne 75% (litres)	Profond. de sculpture (mm)
30.5	850/50R30.5 182D TL	938016	861	1628	692	4778	AG28.00 (H2)				817	23
Bar	1	1.3	1.5	1.9	2.2	2.5	2.8	3.1	3.4	3.7	4	
Psi	15	19	22	28	32	36	41	45	49	54	58	
10 km/h	6430	7500	8210	9640	10705	11665	12390	13120	13845	14575	15300	
25 km/h	5370	6365	7025	8355	9345	10225	10865	11505	12150	12790	13430	
40 km/h	4620	5475	6050	7190	8050	8805	9355	9905	10460	11010	11560	
50 km/h	4110	4875	5380	6400	7160	7835	8325	8815	9310	9800	10290	
65 km/h	3400	4030	4450	5290	5920	6475	6880	7285	7690	8095	8500	

***REMARQUES**

La pression de gonflage se détermine toujours en fonction de la charge par pneu, de la vitesse et du travail à réaliser.

Nos préconisations ci-dessus sont fournies sous réserve de modifications postérieures à la date de diffusion de ces tableaux (mars 2021).

Les données techniques sont susceptibles d'évoluer sans information préalable.

- Pour usage en dévers : ajouter 0,40 bar.
- Pour usage routier intensif : ajouter 0,40 bar.



MICHELIN XP 27

**ENDURANCE AMÉLIORÉE
POUR DES CHARGES
LOURDES ET À BASSE
PRESSION**



PRODUCTIVITÉ



RENTABILITÉ



DIMENSIONS

270/65R16 IMP 134A8/122A8 TL

270/65R18 IMP 136A8/124A8 TL

340/65R18 149A8/137A8 TL

MICHELIN XP 27

Caractéristiques & Pression en bar / psi – Charges par pneu en kg*

Ø pouces	Description	CAI	e mm	D mm	R' mm	Cdr mm	Jante(s) recommandée(s)		Jante(s) tolérée(s)	Chambre à air (Code)	Volume interne 75% (litres)	Profond. de sculpture (mm)			
16	270/65R16 IMP 134A8/122A8 TL	184332	265	755	333	2300	W8		W9 W7	827	45	9			
Bar	1	1.3	1.5	1.9	2.2	2.5	2.8	3.1	3.4	3.7	4	4.1	4.4	4.7	5
Psi	15	19	22	28	32	36	41	45	49	54	58	59	64	68	73
10 km/h	1060	1235	1350	1580	1755	1930	2105	2280	2450	2625	2800	2815	2870	2920	2970
25 km/h	895	1045	1145	1340	1490	1640	1785	1935	2085	2230	2380	2395	2440	2480	2525
30 km/h	840	980	1070	1255	1395	1535	1675	1815	1950	2090	2230	2245	2285	2330	2370
40 km/h	750	875	960	1125	1250	1375	1500	1625	1750	1875	2000	2010	2050	2085	2120
50 km/h	690	805	880	1035	1150	1265	1380	1495	1610	1725	1840	1850	1885	1915	1950

Ø pouces	Description	CAI	e mm	D mm	R' mm	Cdr mm	Jante(s) recommandée(s)		Jante(s) tolérée(s)	Chambre à air (Code)	Volume interne 75% (litres)	Profond. de sculpture (mm)			
18	270/65R18 IMP 136A8/124A8 TL	133069	265	810	361	2472	W8		9 W9	438	51	9			
Bar	1	1.3	1.5	1.9	2.2	2.5	2.8	3.1	3.4	3.7	4	4.1	4.4	4.7	5
Psi	15	19	22	28	32	36	41	45	49	54	58	59	64	68	73
10 km/h	1120	1305	1425	1670	1855	2040	2225	2410	2590	2775	2960	2980	3030	3085	3140
25 km/h	950	1105	1210	1420	1575	1730	1885	2040	2200	2355	2510	2525	2570	2620	2665
30 km/h	890	1035	1135	1330	1480	1625	1770	1920	2065	2215	2360	2375	2420	2465	2510
40 km/h	800	930	1020	1195	1325	1455	1585	1715	1850	1980	2110	2125	2160	2200	2240
50 km/h	730	850	930	1095	1215	1335	1455	1575	1700	1820	1940	1950	1990	2025	2060

Ø pouces	Description	CAI	e mm	D mm	R' mm	Cdr mm	Jante(s) recommandée(s)		Jante(s) tolérée(s)	Chambre à air (Code)	Volume interne 75% (litres)	Profond. de sculpture (mm)			
18	340/65R18 149A8/137A8 TL	415969	343	891	393	2720	11		9 W9	828	80	8			
Bar	1	1.3	1.5	1.9	2.2	2.5	2.8	3.1	3.4	3.7	4	4.1	4.4	4.7	5
Psi	15	19	22	28	32	36	41	45	49	54	58	59	64	68	73
10 km/h	1620	1885	2065	2420	2685	2950	3215	3480	3750	4015	4280	4305	4390	4470	4550
25 km/h	1380	1605	1755	2060	2285	2510	2735	2960	3190	3415	3640	3665	3730	3800	3870
30 km/h	1290	1505	1645	1930	2145	2360	2575	2790	3000	3215	3430	3450	3515	3575	3640
40 km/h	1160	1350	1475	1730	1920	2110	2300	2490	2680	2870	3060	3080	3135	3195	3250
50 km/h	1160	1350	1475	1730	1920	2110	2300	2490	2680	2870	3060	3080	3135	3195	3250

***REMARQUES**

La pression de gonflage se détermine toujours en fonction de la charge par pneu, de la vitesse et du travail à réaliser.
 Nos préconisations ci-dessus sont fournies sous réserve de modifications postérieures à la date de diffusion de ces tableaux (mars 2021).
 Les données techniques sont susceptibles d'évoluer sans information préalable.

XP27: le 1er load index désigne l'usage en roue libre (usage outil traîne), le 2nd désigne l'usage en roue motrice. Les courbes charges/pressions/vitesses sont données pour l'usage en roue libre.
 En roue motrice, une décharge de 30% s'applique.

- Pour usage en dévers >20% : ajouter 0,4 bar.
- Pour usage routier intensif >50% : ajouter 0,4 bar.



MICHELIN XS

**LA RÉFÉRENCE
DES PNEUMATIQUES
BENNE EN BTP**



ENDURANCE

- Carcasse en acier pour une plus grande résistance aux impacts avec capacité de charge plus élevée
- Dessin de la bande de roulement résistant aux dégradations basé sur la technologie des engins de terrassement.



MOBILITÉ

- Bande de roulement large et plate pour un flottement maximum
- Conçu pour le transport sur longue distance jusqu'à 80 km/h.



SÉCURITÉ

- Carcasse flexible et dessin de la bande de roulement conçus pour une conduite à basses pressions.

DIMENSIONS

525/65R20.5 173F TL

24R20.5 176F TL

Caractéristiques & Pression en bar / psi – Charges par pneu en kg*

Ø pouces	Description	CAI	e mm	D mm	R' mm	Cdt. mm	Jante(s) recommandée(s)		Jante(s) tolérée(s)	Chambre à air (Code)	Volume interne 75% (litres)	Profond. de sculpture (mm)	
20.5	525/65R20.5 173F TL	109421	521	1200	549	3640	16.00			19	253	17	
Bar	1.5	1.8	2	2.2	2.4	2.6	2.8	3	3.2	3.4	3.6	3.8	4
Psi	22	26	29	32	35	38	41	44	46	49	52	55	58
30 km/h	2430	2860	3145	3430	3715	4050	4435	4815	4970	5130	5285	5445	5600
40 km/h	2370	2770	3035	3300	3565	3875	4230	4580	4750	4920	5090	5260	5430
50 km/h	2315	2680	2925	3165	3410	3695	4020	4350	4530	4715	4895	5080	5260
65 km/h				3000	3195	3390	3585	3780	3970	4165	4360	4555	4750
80 km/h					2325	2470	2620	2765	2915	3060	3205	3355	3500

Ø pouces	Description	CAI	e mm	D mm	R' mm	Cdt. mm	Jante(s) recommandée(s)		Jante(s) tolérée(s)	Chambre à air (Code)	Volume interne 75% (litres)	Profond. de sculpture (mm)	
20.5	24R20.5 176FTL	109174	602	1374	584	4148	18.00				404	17	
Bar	1.5	1.8	2	2.2	2.4	2.6	2.8	3	3.2	3.4	3.6	3.8	4
Psi	22	26	29	32	35	38	41	44	46	49	52	55	58
30 km/h	3800	4400	4800	5200	5600	6100	6705	7310	7550	7785	8025	8260	8500
40 km/h	3650	4230	4615	5000	5385	5860	6415	6970	7215	7460	7705	7950	8195
50 km/h	3505	4060	4435	4805	5175	5615	6120	6625	6880	7130	7385	7635	7890
65 km/h				4350	4645	4940	5235	5530	5820	6115	6410	6705	7000
80 km/h					3325	3535	3745	3955	4165	4370	4580	4790	5000

***REMARQUES**

La pression de gonflage se détermine toujours en fonction de la charge par pneu, de la vitesse et du travail à réaliser.
 Nos préconisations ci-dessus sont fournies sous réserve de modifications postérieures à la date de diffusion de ces tableaux (mars 2021).
 Les données techniques sont susceptibles d'évoluer sans information préalable.

- Pour usage en dévers >20% : ajouter 0,4 bar.
- Pour usage routier intensif >50% : ajouter 0,4 bar.



MICHELIN XMCL

**UNE GRANDE RÉSISTANCE
AUX AGRESSIONS ET UNE
EXCELLENTE TRACTION
MÊME EN CONDITIONS
HUMIDES ET DIFFICILES**

PNEUS RADIAL

- Jusqu'à 46% de longévité en plus par rapport à un pneu MICHELIN à carcasse diagonale (BIAS)



TRACTION

- Excellente motricité sur sol meuble



PRODUCTIVITÉ

- Flancs renforcés et nappes sommet acier pour une meilleure résistance aux crevaisons



CONFORT

- Organes de la machine préservés



STABILITÉ

- Excellente stabilité en dévers



DIMENSIONS

11LR16 122A8 TL

280/80R18 IND 132A8/132B TL

340/80R18 IND 143A8/143B TL

400/70R18 IND 147A8/147B TL

280/80R20 IND 133A8/133B TL

340/80R20 IND 144A8/144B TL

400/70R20 IND 149A8/149B TL

380/75R20 IND 148A8/148B TL

420/75R20 IND 154A8/154B TL

400/70R24 IND 152A8/152B TL

460/70R24 IND 159A8/159B TL

500/70R24 IND 164A8/164B TL

440/80R24 IND 161A8/161B TL

540/70R24 IND 168A8/168B TL

480/80R26 IND 167A8/167B TL

440/80R28 IND 156A8/156B TL

MICHELIN XMCL

Caractéristiques & Pression en bar / psi – Charges par pneu en kg*

Ø pouces	Description	CAI	e mm	D mm	R' mm	Cdr mm	Jante(s) recommandée(s)	Jante(s) tolérée(s)	Chambre à air (Code)	Volume interne 75% (litres)	Profond. de sculpture (mm)
16	11LR16 122A8 TL <i>XMZ7</i>	123207	291	850	375	2515	W8	W10L	184	60	23
Bar	1.2 1.6 2 2.2 2.4 2.6										
Psi	17 23 29 32 35 38										
10 km/h	1265 1530 1790 1920 2055 2185										
30 km/h	940 1165 1385 1500 1610										
40 km/h	880 1085 1295 1395 1500										

Ø pouces	Description	CAI	e mm	D mm	R' mm	Cdr mm	Jante(s) recommandée(s)	Jante(s) tolérée(s)	Chambre à air (Code)	Volume interne 75% (litres)	Profond. de sculpture (mm)
18	280/80R18 IND 132A8/132B TL <i>10.5 R18 (Equiv 10PR)</i>	779803	290	908	415	2708	W9	W10 W8	438	68	28
Bar	1.6 2 2.2 2.4 2.6 2.8 3 3.2 3.4 3.6 3.8 4 4.2 4.4										
Psi	23 29 32 35 38 41 44 46 49 52 55 58 61 64										
10 km/h Cyc	1170 1430 1565 1695 1825 1955 2085 2220 2350 2480 2610 2740 2870 3000										
25 km/h	1060 1255 1350 1445 1540 1635 1735 1830 1930 2025 2125 2220										
30 km/h	1020 1210 1300 1395 1490 1585 1675 1770 1865 1955 2050 2140										
40 km/h	950 1125 1215 1300 1390 1475 1565 1650 1740 1825 1915 2000										
50 km/h	950 1125 1215 1300 1390 1475 1565 1650 1740 1825 1915 2000										
Stat	1800 2200 2400 2600 2800 3000 3200 3400 3600 3800 4000 4200 4400 4600										

Ø pouces	Description	CAI	e mm	D mm	R' mm	Cdr mm	Jante(s) recommandée(s)	Jante(s) tolérée(s)	Chambre à air (Code)	Volume interne 75% (litres)	Profond. de sculpture (mm)
18	340/80R18 IND 143A8/143B TL <i>12.5 R18 (Equiv 12PR)</i>	100054	351	996	448	2959	11	W10 W11 12 11SDC 12SDC	444 828	107	31
Bar	1.6 2 2.2 2.4 2.6 2.8 3 3.2 3.4 3.6 3.8 4 4.2 4.4										
Psi	23 29 32 35 38 41 44 46 49 52 55 58 61 64										
10 km/h Cyc	1600 1955 2135 2310 2490 2670 2845 3025 3200 3380 3555 3735 3915 4090										
25 km/h	1450 1715 1845 1975 2105 2240 2370 2500 2630 2760 2890 3020										
30 km/h	1390 1645 1775 1900 2030 2155 2285 2410 2540 2665 2795 2920										
40 km/h	1320 1550 1665 1780 1895 2010 2125 2240 2360 2485 2605 2725										
50 km/h	1320 1550 1665 1780 1895 2010 2125 2240 2360 2485 2605 2725										
Stat	2450 2995 3270 3540 3815 4090 4360 4635 4905 5180 5455 5725 6000 6270										

* Se référer aux remarques en fin des tableaux de cette gamme

MICHELIN XMCL

Caractéristiques & Pression en bar / psi – Charges par pneu en kg*

Ø pouces	Description	CAI	e mm	D mm	R' mm	Cdr mm	Jante(s) recommandée(s)		Jante(s) tolérée(s)	Chambre à air (Code)	Volume interne 75% (litres)	Profond. de sculpture (mm)		
18	400/70R18 IND 147A8/147B TL <i>405/70 R18</i>	133035	404	1013	454	3008	13		12	W13	129	31		
									13.00					
Bar	1.6	2	2.2	2.4	2.6	2.8	3	3.2	3.4	3.6	3.8	4	4.2	4.4
Psi	23	29	32	35	38	41	44	46	49	52	55	58	61	64
10 km/h Cyc	1825	2215	2415	2610	2805	3000	3215	3435	3650	3865	4050	4240	4430	4615
25 km/h	1670	1945	2085	2220	2380	2540	2700	2860	3000	3140	3275	3415		
30 km/h	1605	1875	2005	2140	2295	2450	2600	2755	2890	3025	3155	3290		
40 km/h	1500	1750	1875	2000	2145	2290	2430	2575	2700	2825	2950	3075		
50 km/h	1500	1750	1875	2000	2145	2290	2430	2575	2700	2825	2950	3075		
Stat	2800	3400	3700	4000	4300	4600	4930	5265	5595	5925	6215	6500	6790	7075

Ø pouces	Description	CAI	e mm	D mm	R' mm	Cdr mm	Jante(s) recommandée(s)		Jante(s) tolérée(s)	Chambre à air (Code)	Volume interne 75% (litres)	Profond. de sculpture (mm)		
20	280/80R20 IND 133A8/133B TL <i>10.5 R20 (Equiv 10PR)</i>	747442	292	958	439	2860	W9		W8	W10	542	73	31	
									W10					
Bar	1.6	2	2.2	2.4	2.6	2.8	3	3.2	3.4	3.6	3.8	4	4.2	4.4
Psi	23	29	32	35	38	41	44	46	49	52	55	58	61	64
10 km/h Cyc	1210	1480	1610	1745	1880	2015	2150	2280	2415	2550	2685	2820	2955	3090
25 km/h	1090	1290	1390	1490	1590	1690	1790	1890	1990	2090	2190	2290		
30 km/h	1050	1245	1340	1435	1530	1625	1725	1820	1915	2010	2105	2200		
40 km/h	975	1155	1245	1340	1430	1520	1610	1700	1790	1880	1970	2060		
50 km/h	975	1155	1245	1340	1430	1520	1610	1700	1790	1880	1970	2060		
Stat	1850	2260	2470	2675	2880	3085	3290	3500	3705	3910	4120	4325	4535	4740

Ø pouces	Description	CAI	e mm	D mm	R' mm	Cdr mm	Jante(s) recommandée(s)		Jante(s) tolérée(s)	Chambre à air (Code)	Volume interne 75% (litres)	Profond. de sculpture (mm)		
20	340/80R20 IND 144A8/144B TL <i>12.5 R20 (Equiv 12PR)</i>	948730	353	1047	476	3119	11		W10	W11	664	114	31	
									12					
Bar	1.6	2	2.2	2.4	2.6	2.8	3	3.2	3.4	3.6	3.8	4	4.2	4.4
Psi	23	29	32	35	38	41	44	46	49	52	55	58	61	64
10 km/h Cyc	1640	2005	2190	2370	2555	2740	2920	3105	3285	3470	3650	3835	4020	4200
25 km/h	1490	1760	1895	2030	2165	2300	2435	2570	2705	2840	2975	3110		
30 km/h	1430	1690	1820	1950	2080	2210	2340	2470	2605	2735	2870	3000		
40 km/h	1360	1595	1715	1830	1950	2065	2185	2300	2425	2550	2675	2800		
50 km/h	1360	1595	1715	1830	1950	2065	2185	2300	2425	2550	2675	2800		
Stat	2520	3080	3360	3640	3920	4200	4480	4760	5040	5320	5600	5880	6160	6440

* Se référer aux remarques en fin des tableaux de cette gamme

MICHELIN XMCL

Caractéristiques & Pression en bar / psi – Charges par pneu en kg*

Ø pouces	Description	CAI	e mm	D mm	R' mm	Cdr mm	Jante(s) recommandée(s)		Jante(s) tolérée(s)	Chambre à air (Code)	Volume interne 75% (litres)	Profond. de sculpture (mm)			
20	400/70R20 IND 149A8/149B TL <i>16.0/70 R20 (Equiv 16PR)</i>	474495	412	1069	481	3177	W13		13 14 12 12SDC 13SDC DW13	664	140	33			
	Bar	1.6	2	2.2	2.4	2.6	2.8	3	3.2	3.4	3.6	3.8	4	4.2	4.4
	Psi	23	29	32	35	38	41	44	46	49	52	55	58	61	64
	10 km/h Cyc	1910	2335	2545	2760	2970	3180	3395	3605	3820	4030	4245	4455	4670	4880
	25 km/h	1730	2045	2200	2355	2510	2670	2825	2980	3140	3295	3455	3610		
	30 km/h	1660	1965	2115	2265	2415	2570	2720	2870	3025	3175	3330	3480		
	40 km/h	1550	1825	1965	2100	2240	2375	2515	2650	2800	2950	3100	3250		
	50 km/h	1550	1825	1965	2100	2240	2375	2515	2650	2800	2950	3100	3250		
	Stat	2930	3580	3905	4230	4555	4880	5205	5530	5855	6180	6505	6830	7155	7480

Ø pouces	Description	CAI	e mm	D mm	R' mm	Cdr mm	Jante(s) recommandée(s)		Jante(s) tolérée(s)	Chambre à air (Code)	Volume interne 75% (litres)	Profond. de sculpture (mm)			
20	380/75R20 IND 148A8/148B TL <i>14.5 R20 (Equiv 12PR)</i>	187752	384	1070	481	3180	W12		11 W11 12	664	136	33			
	Bar	1.6	2	2.2	2.4	2.6	2.8	3	3.2	3.4	3.6	3.8	4	4.2	4.4
	Psi	23	29	32	35	38	41	44	46	49	52	55	58	61	64
	10 km/h Cyc	1850	2260	2465	2670	2875	3080	3285	3490	3695	3900	4110	4315	4525	4730
	25 km/h	1670	1975	2130	2280	2435	2585	2740	2890	3045	3195	3350	3500		
	30 km/h	1610	1905	2050	2195	2340	2490	2635	2780	2930	3075	3225	3370		
	40 km/h	1500	1770	1905	2040	2170	2305	2440	2575	2720	2865	3005	3150		
	50 km/h	1500	1770	1905	2040	2170	2305	2440	2575	2720	2865	3005	3150		
	Stat	2840	3470	3785	4100	4415	4730	5045	5360	5675	5990	6305	6620	6935	7250

Ø pouces	Description	CAI	e mm	D mm	R' mm	Cdr mm	Jante(s) recommandée(s)		Jante(s) tolérée(s)	Chambre à air (Code)	Volume interne 75% (litres)	Profond. de sculpture (mm)			
20	420/75R20 IND 154A8/154B TL <i>16.5/75 R20 (Equiv 18PR)</i>	967201	428	1138	509	3378	13		14 12 12SDC 13SDC	664	172	33			
	Bar	1.6	2	2.2	2.4	2.6	2.8	3	3.2	3.4	3.6	3.8	4	4.2	4.4
	Psi	23	29	32	35	38	41	44	46	49	52	55	58	61	64
	10 km/h Cyc	2200	2690	2935	3180	3425	3670	3915	4160	4405	4650	4895	5140	5385	5630
	25 km/h	1990	2355	2535	2715	2895	3080	3260	3440	3620	3800	3980	4160		
	30 km/h	1920	2270	2440	2615	2790	2965	3135	3310	3485	3660	3835	4010		
	40 km/h	1800	2120	2280	2440	2595	2755	2915	3075	3245	3415	3580	3750		
	50 km/h	1800	2120	2280	2440	2595	2755	2915	3075	3245	3415	3580	3750		
	Stat	3380	4130	4505	4880	5255	5630	6005	6380	6755	7130	7505	7880	8255	8630

* Se référer aux remarques en fin des tableaux de cette gamme

MICHELIN XMCL

Caractéristiques & Pression en bar / psi – Charges par pneu en kg*

Ø pouces	Description	CAI	e mm	D mm	R' mm	Cdr mm	Jante(s) recommandée(s)		Jante(s) tolérée(s)	Chambre à air (Code)	Volume interne 75% (litres)	Profond. de sculpture (mm)		
24	400/70R24 IND 152A8/152B TL <i>16.0/70 R24 (Equiv 16PR)</i>	178690	401	1170	531	3485	DW13L		13 DW13 DW14L 13SDC DW12	703	157	33		
Bar	1.6	2	2.2	2.4	2.6	2.8	3	3.2	3.4	3.6	3.8	4	4.2	4.4
Psi	23	29	32	35	38	41	44	46	49	52	55	58	61	64
10 km/h Cyc	2040	2500	2735	2965	3195	3425	3655	3890	4120	4350	4595	4840	5080	5325
25 km/h	1830	2180	2350	2525	2700	2875	3045	3220	3400	3580	3760	3940		
30 km/h	1765	2100	2270	2435	2605	2770	2940	3105	3280	3455	3625	3800		
40 km/h	1650	1965	2120	2275	2430	2590	2745	2900	3065	3225	3390	3550		
50 km/h	1650	1965	2120	2275	2430	2590	2745	2900	3065	3225	3390	3550		
Stat	3130	3840	4190	4545	4900	5255	5610	5960	6315	6670	7045	7420	7790	8165

Ø pouces	Description	CAI	e mm	D mm	R' mm	Cdr mm	Jante(s) recommandée(s)		Jante(s) tolérée(s)	Chambre à air (Code)	Volume interne 75% (litres)	Profond. de sculpture (mm)		
24	460/70R24 IND 159A8/159B TL <i>17.5 LR24 (Equiv 18PR)</i>	244268	467	1248	562	3709	DW15L		14 DW14L TW14L DW16L 16	710	218	36		
Bar	1.6	2	2.2	2.4	2.6	2.8	3	3.2	3.4	3.6	3.8	4	4.2	4.4
Psi	23	29	32	35	38	41	44	46	49	52	55	58	61	64
10 km/h Cyc	2570	3140	3425	3710	3995	4280	4565	4850	5135	5420	5705	5990	6275	6560
25 km/h	2320	2745	2955	3165	3375	3585	3800	4010	4225	4435	4650	4860		
30 km/h	2240	2650	2850	3055	3260	3460	3665	3870	4075	4275	4480	4680		
40 km/h	2120	2505	2695	2885	3075	3270	3460	3650	3830	4015	4195	4375		
50 km/h	2120	2505	2695	2885	3075	3270	3460	3650	3830	4015	4195	4375		
Stat	3940	4815	5250	5690	6125	6560	7000	7435	7875	8310	8750	9185	9625	10060

Ø pouces	Description	CAI	e mm	D mm	R' mm	Cdr mm	Jante(s) recommandée(s)		Jante(s) tolérée(s)	Chambre à air (Code)	Volume interne 75% (litres)	Profond. de sculpture (mm)		
24	500/70R24 IND 164A8/164B TL <i>19.5 LR24 (Equiv 20PR)</i>	542794	511	1302	583	3866	DW16L		DW15L 16	710	266	36		
Bar	1.6	2	2.2	2.4	2.6	2.8	3	3.2	3.4	3.6	3.8	4	4.2	4.4
Psi	23	29	32	35	38	41	44	46	49	52	55	58	61	64
10 km/h Cyc	2930	3585	3910	4240	4565	4890	5220	5545	5875	6200	6525	6850	7175	7500
25 km/h	2650	3135	3375	3615	3855	4100	4340	4580	4825	5065	5310	5550		
30 km/h	2560	3025	3260	3490	3725	3955	4190	4420	4655	4885	5120	5350		
40 km/h	2360	2800	3020	3245	3465	3685	3905	4125	4345	4565	4780	5000		
50 km/h	2360	2800	3020	3245	3465	3685	3905	4125	4345	4565	4780	5000		
Stat	4500	5500	6000	6500	7000	7500	8000	8500	9000	9500	10000	10500	11000	11500

* Se référer aux remarques en fin des tableaux de cette gamme

MICHELIN XMCL

Caractéristiques & Pression en bar / psi – Charges par pneu en kg*

Ø pouces	Description	CAI	e mm	D mm	R' mm	Cdk mm	Jante(s) recommandée(s)	Jante(s) tolérée(s)	Chambre à air (Code)	Volume interne 75% (litres)	Profond. de sculpture (mm)			
24	440/80R24 IND 161A8/161B TL <i>16,9 R24 (Equiv 18PR)</i>	954749	441	1314	592	3907	DW14L	14 TW14L DW15L	710	236	36			
Bar	1.6	2	2.2	2.4	2.6	2.8	3	3.2	3.4	3.6	3.8	4	4.2	4.4
Psi	23	29	32	35	38	41	44	46	49	52	55	58	61	64
10 km/h Cyc	2710	3315	3615	3920	4220	4520	4825	5125	5430	5730	6030	6335	6640	6940
25 km/h	2460	2905	3130	3350	3575	3795	4020	4240	4465	4685	4910	5130		
30 km/h	2370	2800	3015	3230	3445	3660	3875	4090	4305	4520	4735	4950		
40 km/h	2240	2650	2855	3060	3260	3465	3670	3875	4065	4250	4440	4625		
50 km/h	2240	2650	2855	3060	3260	3465	3670	3875	4065	4250	4440	4625		
Stat	4160	5085	5550	6010	6475	6940	7400	7865	8325	8790	9255	9715	10180	10640

Ø pouces	Description	CAI	e mm	D mm	R' mm	Cdk mm	Jante(s) recommandée(s)	Jante(s) tolérée(s)	Chambre à air (Code)	Volume interne 75% (litres)	Profond. de sculpture (mm)			
24	540/70R24 IND 168A8/168B TL <i>21 LR24 (Equiv 20PR)</i>	959128	562	1356	608	4026	DW18L	DW16L	710	317	36			
Bar	1.6	2	2.2	2.4	2.6	2.8	3	3.2	3.4	3.6	3.8	4	4.2	4.4
Psi	23	29	32	35	38	41	44	46	49	52	55	58	61	64
10 km/h Cyc	3270	3855	4145	4440	4730	5020	5315	5605	5900	6190	6740	7295	7850	8400
25 km/h	2940	3490	3765	4040	4310	4585	4860	5135	5405	5680	5950	6220		
30 km/h	2840	3370	3630	3895	4160	4425	4685	4950	5215	5475	5740	6000		
40 km/h	2650	3145	3390	3640	3885	4130	4380	4625	4870	5115	5355	5600		
50 km/h	2650	3145	3390	3640	3885	4130	4380	4625	4870	5115	5355	5600		
Stat	5015	5910	6360	6805	7255	7700	8150	8595	9045	9490	10335	11185	12035	12880

Ø pouces	Description	CAI	e mm	D mm	R' mm	Cdk mm	Jante(s) recommandée(s)	Jante(s) tolérée(s)	Chambre à air (Code)	Volume interne 75% (litres)	Profond. de sculpture (mm)			
26	480/80R26 IND 167A8/167B TL <i>18,4 R26 (Equiv 20PR)</i>	425979	495	1422	636	4218	DW15L	DW16L	716	302	36			
Bar	1.6	2	2.2	2.4	2.6	2.8	3	3.2	3.4	3.6	3.8	4	4.2	4.4
Psi	23	29	32	35	38	41	44	46	49	52	55	58	61	64
10 km/h Cyc	3200	3910	4265	4620	4975	5330	5685	6040	6395	6750	7460	8175		
25 km/h	2890	3420	3680	3945	4210	4475	4735	5000	5265	5525	5790	6050		
30 km/h	2790	3300	3550	3805	4060	4315	4565	4820	5075	5330	5580	5835		
40 km/h	2575	3055	3295	3540	3780	4020	4260	4500	4740	4975	5215	5450		
50 km/h	2575	3055	3295	3540	3780	4020	4260	4500	4740	4975	5215	5450		
Stat	4900	5990	6535	7080	7625	8170	8715	9260	9805	10350	10895	11445	11990	12535

* Se référer aux remarques en fin des tableaux de cette gamme

MICHELIN XMCL

Caractéristiques & Pression en bar / psi – Charges par pneu en kg*

Ø pouces	Description	CAI	e mm	D mm	R' mm	Cdr mm	Jante(s) recommandée(s)	Jante(s) tolérée(s)	Chambre à air (Code)	Volume interne 75% (litres)	Profond. de sculpture (mm)
28	440/80R28 IND 156A8/156B TL <i>16.9 R28 (Equiv 18PR)</i>	316223	459	1410	641	4200	DW14L	DW15L	822	260	36
Bar	1.6 2 2.2 2.4 2.6 2.8 3 3.2 3.4 3.6										
Psi	23 29 32 35 38 41 44 46 49 52										
10 km/h Cyc	2840 3470 3790	4105 4420 4735	5050 5370 5685	6000							
25 km/h	2570 3040 3270	3505 3740 3970	4205 4440								
30 km/h	2480 2930 3155	3380 3605 3830	4055 4280								
40 km/h	2300 2725 2940	3150 3365 3575	3790 4000								
50 km/h	2300 2725 2940	3150 3365 3575	3790 4000								
Stat	4360 5330 5810	6295 6780 7265	7750 8230 8715	9200							

***REMARQUES :**

La pression de gonflage se détermine toujours en fonction de la charge par pneu, de la vitesse et du travail à réaliser.
 Nos préconisations ci-dessus sont fournies sous réserve de modifications postérieures à la date de diffusion de ces tableaux (mars 2021).
 Les données techniques sont susceptibles d'évoluer sans information préalable.

- Pour usage en dévers >20% : ajouter 0,4 bar.
- Pour usage routier intensif >50% : ajouter 0,4 bar.
- Stat = véhicule immobile
- 10 km/h Cyc: Vitesse maxi 10 km/h avec charge cyclique.



MICHELIN BIBLOAD HARD SURFACE

**LE PNEU QUI OFFRE PLUS DE
RÉSISTANCE SUR SOLS DURS
ET RÉDUIT LES VIBRATIONS**

PNEUS RADIAL

- Jusqu'à 46% de longévité en plus par rapport à un pneu MICHELIN à carcasse diagonale (BIAS)



TRACTION

- Excellente motricité sur sol meuble



PRODUCTIVITÉ

- Flancs renforcés et nappes sommet acier pour une meilleure résistance aux crevaisons



CONFORT

- Organes de la machine préservés



STABILITÉ

- Excellente stabilité en dévers



DIMENSIONS

340/80R18 IND 143A8/143B TL

400/70R18 IND 147A8/147B TL

340/80R20 IND 144A8/144B TL

400/70R20 IND 149A8/149B TL

460/70R24 IND 159A8/159B TL

440/80R24 IND 161A8/161B TL

500/70R24 IND 164A8/164B TL

540/70R24 IND 168A8/168B TL

480/80R26 IND 167A8/167B TL

440/80R28 IND 163A8/163B TL

MICHELIN BIBLOAD HARD SURFACE

Caractéristiques & Pression en bar / psi – Charges par pneu en kg*

Ø pouces	Description	CAI	e mm	D mm	R' mm	Cdr mm	Jante(s) recommandée(s)	Jante(s) tolérée(s)	Chambre à air (Code)	Volume interne 75% (litres)	Profond. de sculpture (mm)				
18	340/80R18 IND 143A8/143B TL <i>12.5 R18 (Equiv 12PR)</i>	415829	342	990	448	2946	W11	W10 11 12 11SDC 12SDC	828 444	107	28				
Bar	1.6	1.8	2	2.2	2.4	2.6	2.8	3	3.2	3.4	3.6	3.8	4	4.2	4.4
Psi	23	26	29	32	35	38	41	44	46	49	52	55	58	61	64
10 km/h Cyc	1600	1780	1955	2135	2310	2490	2670	2845	3025	3200	3380	3555	3735	3915	4090
25 km/h	1450	1580	1715	1845	1975	2105	2240	2370	2500	2630	2760	2890	3020		
30 km/h	1390	1520	1645	1775	1900	2030	2155	2285	2410	2540	2665	2795	2920		
40 km/h	1320	1435	1550	1665	1780	1895	2010	2125	2240	2360	2485	2605	2725		
50 km/h	1320	1435	1550	1665	1780	1895	2010	2125	2240	2360	2485	2605	2725		
Stat	2450	2725	2995	3270	3540	3815	4090	4360	4635	4905	5180	5455	5725	6000	6270

Ø pouces	Description	CAI	e mm	D mm	R' mm	Cdr mm	Jante(s) recommandée(s)	Jante(s) tolérée(s)	Chambre à air (Code)	Volume interne 75% (litres)	Profond. de sculpture (mm)				
18	400/70R18 IND 147A8/147B TL <i>405/70 R18 (Equiv 14PR)</i>	239365	397	1006	448	2983	13	12 13.00 12SDC		129	29				
Bar	1.6	1.8	2	2.2	2.4	2.6	2.8	3	3.2	3.4	3.6	3.8	4	4.2	4.4
Psi	23	26	29	32	35	38	41	44	46	49	52	55	58	61	64
10 km/h Cyc	1825	2020	2215	2415	2610	2805	3000	3215	3435	3650	3865	4050	4240	4430	4615
25 km/h	1670	1810	1945	2085	2220	2380	2540	2700	2860	3000	3140	3275	3415		
30 km/h	1605	1740	1875	2005	2140	2295	2450	2600	2755	2890	3025	3155	3290		
40 km/h	1500	1625	1750	1875	2000	2145	2290	2430	2575	2700	2825	2950	3075		
50 km/h	1500	1625	1750	1875	2000	2145	2290	2430	2575	2700	2825	2950	3075		
Stat	2800	3100	3400	3700	4000	4300	4600	4930	5265	5595	5925	6215	6500	6790	7075

Ø pouces	Description	CAI	e mm	D mm	R' mm	Cdr mm	Jante(s) recommandée(s)	Jante(s) tolérée(s)	Chambre à air (Code)	Volume interne 75% (litres)	Profond. de sculpture (mm)				
20	340/80R20 IND 144A8/144B TL <i>12.5 R20 (Equiv 12PR)</i>	991253	346	1041	473	3100	11	W10 W11 12 11SDC 12SDC	664 444	114	28				
Bar	1.6	1.8	2	2.2	2.4	2.6	2.8	3	3.2	3.4	3.6	3.8	4	4.2	4.4
Psi	23	26	29	32	35	38	41	44	46	49	52	55	58	61	64
10 km/h Cyc	1640	1825	2005	2190	2370	2555	2740	2920	3105	3285	3470	3650	3835	4020	4200
25 km/h	1490	1625	1760	1895	2030	2165	2300	2435	2570	2705	2840	2975	3110		
30 km/h	1430	1560	1690	1820	1950	2080	2210	2340	2470	2605	2735	2870	3000		
40 km/h	1360	1480	1595	1715	1830	1950	2065	2185	2300	2425	2550	2675	2800		
50 km/h	1360	1480	1595	1715	1830	1950	2065	2185	2300	2425	2550	2675	2800		
Stat	2520	2800	3080	3360	3640	3920	4200	4480	4760	5040	5320	5600	5880	6160	6440

* Se référer aux remarques en fin des tableaux de cette gamme

MICHELIN BIBLOAD HARD SURFACE

Caractéristiques & Pression en bar / psi – Charges par pneu en kg*

Ø pouces	Description	CAI	e mm	D mm	R' mm	Cdr mm	Jante(s) recommandée(s)	Jante(s) tolérée(s)	Chambre à air (Code)	Volume interne 75% (litres)	Profond. de sculpture (mm)																
20	400/70R20 IND 149A8/149B TL <i>16.0/70 R20 (Equiv 16PR)</i>	793611	403	1068	480	3174	W13	13 14 12 12SDC 13SDC DW13	664	140	29																
												Bar	1.6	1.8	2	2.2	2.4	2.6	2.8	3	3.2	3.4	3.6	3.8	4	4.2	4.4
												Psi	23	26	29	32	35	38	41	44	46	49	52	55	58	61	64
												10 km/h Cyc	1910	2120	2335	2545	2760	2970	3180	3395	3605	3820	4030	4245	4455	4670	4880
												25 km/h	1730	1885	2045	2200	2355	2510	2670	2825	2980	3140	3295	3455	3610		
												30 km/h	1660	1810	1965	2115	2265	2415	2570	2720	2870	3025	3175	3330	3480		
												40 km/h	1550	1690	1825	1965	2100	2240	2375	2515	2650	2800	2950	3100	3250		
												50 km/h	1550	1690	1825	1965	2100	2240	2375	2515	2650	2800	2950	3100	3250		
												Stat	2930	3255	3580	3905	4230	4555	4880	5205	5530	5855	6180	6505	6830	7155	7480

Ø pouces	Description	CAI	e mm	D mm	R' mm	Cdr mm	Jante(s) recommandée(s)	Jante(s) tolérée(s)	Chambre à air (Code)	Volume interne 75% (litres)	Profond. de sculpture (mm)																
24	460/70R24 IND 159A8/159B TL <i>17.5 LR24 (Equiv 18PR)</i>	372690	467	1241	558	3688	DW15L	14 DW14L DW16L 16	710	218	33																
												Bar	1.6	1.8	2	2.2	2.4	2.6	2.8	3	3.2	3.4	3.6	3.8	4	4.2	4.4
												Psi	23	26	29	32	35	38	41	44	46	49	52	55	58	61	64
												10 km/h Cyc	2570	2855	3140	3425	3710	3995	4280	4565	4850	5135	5420	5705	5990	6275	6560
												25 km/h	2320	2530	2745	2955	3165	3375	3585	3800	4010	4225	4435	4650	4860		
												30 km/h	2240	2445	2650	2850	3055	3260	3460	3665	3870	4075	4275	4480	4680		
												40 km/h	2120	2310	2505	2695	2885	3075	3270	3460	3650	3830	4015	4195	4375		
												50 km/h	2120	2310	2505	2695	2885	3075	3270	3460	3650	3830	4015	4195	4375		
												Stat	3940	4375	4815	5250	5690	6125	6560	7000	7435	7875	8310	8750	9185	9625	10060

Ø pouces	Description	CAI	e mm	D mm	R' mm	Cdr mm	Jante(s) recommandée(s)	Jante(s) tolérée(s)	Chambre à air (Code)	Volume interne 75% (litres)	Profond. de sculpture (mm)																
24	440/80R24 IND 161A8/161B TL <i>16.9 R24 (Equiv 18PR)</i>	814805	448	1299	584	3860	DW14L	14 DW15L	710	234	32																
												Bar	1.6	1.8	2	2.2	2.4	2.6	2.8	3	3.2	3.4	3.6	3.8	4	4.2	4.4
												Psi	23	26	29	32	35	38	41	44	46	49	52	55	58	61	64
												10 km/h Cyc	2775	3080	3380	3685	3990	4295	4595	4900	5205	5505	5810	6095	6375	6660	6940
												25 km/h	2500	2720	2935	3155	3370	3590	3805	4025	4240	4475	4705	4940	5170		
												30 km/h	2390	2630	2865	3105	3340	3580	3815	4055	4290	4485	4680	4875	5070		
												40 km/h	2180	2375	2575	2770	2965	3160	3355	3555	3750	3970	4190	4405	4625		
												50 km/h	2180	2375	2575	2770	2965	3160	3355	3555	3750	3970	4190	4405	4625		
												Stat	4255	4720	5185	5650	6115	6585	7050	7515	7980	8445	8910	9345	9775	10210	10640

* Se référer aux remarques en fin des tableaux de cette gamme

MICHELIN BIBLOAD HARD SURFACE

Caractéristiques & Pression en bar / psi – Charges par pneu en kg*

Ø pouces	Description	CAI	e mm	D mm	R' mm	Cdr mm	Jante(s) recommandé(s)	Jante(s) tolérée(s)	Chambre à air (Code)	Volume interne 75% (litres)	Profond. de sculpture (mm)
24	500/70R24 IND 164A8/164B TL <i>19.4 LR24 (Equiv 20PR)</i>	346709	499	1299	594	3874	DW16L	DW15L 16	710	266	32
Bar	1.6 1.8 2	2.2 2.4 2.6	2.8 3	3.2 3.4 3.6	3.8 4	4.2 4.4					
Psi	23 26 29	32 35 38	41 44 46	49 52 55	58 61 64						
10 km/h Cyc	2930 3255 3585	3910 4240 4565	4890 5220 5545	5875 6200 6525	6850 7175 7500						
25 km/h	2650 2890 3135	3375 3615 3855	4100 4340 4580	4825 5065 5310	5550						
30 km/h	2560 2795 3025	3260 3490 3725	3955 4190 4420	4655 4885 5120	5350						
40 km/h	2360 2580 2800	3020 3245 3465	3685 3905 4125	4345 4565 4780	5000						
50 km/h	2360 2580 2800	3020 3245 3465	3685 3905 4125	4345 4565 4780	5000						
Stat	4500 5000 5500	6000 6500 7000	7500 8000 8500	9000 9500 10000	10500 11000 11500						

Ø pouces	Description	CAI	e mm	D mm	R' mm	Cdr mm	Jante(s) recommandé(s)	Jante(s) tolérée(s)	Chambre à air (Code)	Volume interne 75% (litres)	Profond. de sculpture (mm)
24	540/70R24 IND 168A8/168B TL <i>21 LR24 (Equiv 20PR)</i>	005412	567	1341	600	3981	DW18L	DW16L	710	317	33
Bar	1.6 1.8 2	2.2 2.4 2.6	2.8 3	3.2 3.4 3.6	3.8 4	4.2 4.4					
Psi	23 26 29	32 35 38	41 44 46	49 52 55	58 61 64						
10 km/h Cyc	3270 3560 3855	4145 4440 4730	5020 5315 5605	5900 6190 6740	7295 7850 8400						
25 km/h	2940 3215 3490	3765 4040 4310	4585 4860 5135	5405 5680 5950	6220						
30 km/h	2840 3105 3370	3630 3895 4160	4425 4685 4950	5215 5475 5740	6000						
40 km/h	2650 2895 3145	3390 3640 3885	4130 4380 4625	4870 5115 5355	5600						
50 km/h	2650 2895 3145	3390 3640 3885	4130 4380 4625	4870 5115 5355	5600						
Stat	5015 5465 5910	6360 6805 7255	7700 8150 8595	9045 9490 10335	11185 12035 12880						

Ø pouces	Description	CAI	e mm	D mm	R' mm	Cdr mm	Jante(s) recommandée(s)	Jante(s) tolérée(s)	Chambre à air (Code)	Volume interne 75% (litres)	Profond. de sculpture (mm)
26	480/80R26 IND 167A8/167B TL <i>18.4 R26 (Equiv 20PR)</i>	886709	509	1419	637	4215	DW15L	DW16L	716	304	33
Bar	1.6 1.8 2	2.2 2.4 2.6	2.8 3	3.2 3.4 3.6	3.8 4	4.2 4.4					
Psi	23 26 29	32 35 38	41 44 46	49 52 55	58 61 64						
10 km/h Cyc	3200 3555 3910	4265 4620 4975	5330 5685 6040	6395 6750 7460	8175						
25 km/h	2890 3155 3420	3680 3945 4210	4475 4735 5000	5265 5525 5790	6050						
30 km/h	2790 3045 3300	3550 3805 4060	4315 4565 4820	5075 5330 5580	5835						
40 km/h	2575 2815 3055	3295 3540 3780	4020 4260 4500	4740 4975 5215	5450						
50 km/h	2575 2815 3055	3295 3540 3780	4020 4260 4500	4740 4975 5215	5450						
Stat	4900 5445 5990	6535 7080 7625	8170 8715 9260	9805 10350 10895	11445 11990 12535						

* Se référer aux remarques en fin des tableaux de cette gamme

MICHELIN BIBLOAD HARD SURFACE

Caractéristiques & Pression en bar / psi – Charges par pneu en kg*

Ø pouces	Description	CAI	e mm	D mm	R' mm	Cdr mm	Jante(s) recommandée(s)	Jante(s) tolérée(s)	Chambre à air (Code)	Volume interne 75% (litres)	Profond. de sculpture (mm)
28	440/80R28 IND 163A8/163B TL <i>16.9 R28 (Equiv 18PR)</i>	195802	446	1407	637	4188	DW14L	DW15L	822	259	33
Bar	1.6 1.8 2 2.2 2.4 2.6 2.8 3 3.2 3.4 3.6 3.8 4 4.2 4.4										
Psi	23 26 29 32 35 38 41 44 46 49 52 55 58 61 64										
10 km/h Cyc	2850 3275 3700	4125 4550 4975 5400	5825 6250 6675 7100	7525 7950							
25 km/h	2620 2855 3085	3320 3550 3785 4015	4250 4480 4715 4945	5180 5410							
30 km/h	2525 2750 2975	3200 3420 3645 3870	4095 4320 4545 4765	4990 5215							
40 km/h	2360 2570 2780	2990 3200 3410 3620	3825 4035 4245 4455	4665 4875							
50 km/h	2360 2570 2780	2990 3200 3410 3620	3825 4035 4245 4455	4665 4875							
Stat	4370 4930 5485	6045 6605 7165 7720	8280 8840 9395 9955	10515 11075 11630 12190							

***REMARQUES :**

La pression de gonflage se détermine toujours en fonction de la charge par pneu, de la vitesse et du travail à réaliser.
 Nos préconisations ci-dessus sont fournies sous réserve de modifications postérieures à la date de diffusion de ces tableaux (mars 2021).
 Les données techniques sont susceptibles d'évoluer sans information préalable.

- Pour usage en dévers >20% : ajouter 0,4 bar.
- Pour usage routier intensif >50% : ajouter 0,4 bar.
- Stat = véhicule immobile
- 10 km/h Cyc: Vitesse maxi 10 km/h avec charge cyclique.



MICHELIN CROSSGRIP

UN PNEU POLYVALENT
POUR UNE UTILISATION
SUR ROUTE, HERBE
ET NEIGE



POLYVALENCE

- Exploitation tout au long de l'année



PRODUCTIVITÉ

- Meilleure charge à 65 km/h⁽¹⁾
- Flancs renforcés et nappes sommet acier pour une meilleure résistance aux crevaisons



TRACTION

- Très bon sur neige et sols meubles



Tractopelles



Chargeuses



Tracteurs



Télescopiques

(1) Pour la dimension 440/80 R28 163A8/158D IND TL, le MICHELIN 158D tire peut supporter 4,250 kg à 65 km/h alors que les 151D des concurrents supportent 3,450 Kg à 65 km/h. Source : ETRTO standard.

DIMENSIONS

250/80R16 IND 124A8/120D TL

340/80R18 IND 143A8/138D TL

360/80R24 IND 150A8/145D TL **NEW**

400/80R24 IND 156A8/151D TL

460/70R24 IND 159A8/154D TL

500/70R24 IND 164A8/159D TL

440/80R24 IND 161A8/156D TL

400/80R28 IND 158A8/153D TL

440/80R28 IND 163A8/158D TL

440/80R34 IND 159A8/155D TL **NEW**

480/80R34 IND 164A8/159D TL **NEW**

480/80R38 IND 166A8/161D TL

MICHELIN CROSSGRIP

Caractéristiques & Pression en bar / psi – Charges par pneu en kg*

Ø pouces	Description	CAI	e mm	D mm	R' mm	Cdr. mm	Jante(s) recommandée(s)	Jante(s) tolérée(s)	Chambre à air (Code)	Volume interne 75% (litres)	Profond. de sculpture (mm)
16	250/80R16 IND 124A8/120D TL <i>7.5 R16</i>	564847	259	804	364	2402	W8	W9 W7	184	48	17
Bar	1.6 1.8 2 2.2 2.4 2.6 2.8 3 3.2 3.4 3.6 3.8 4 4.2 4.4										
Psi	23 26 29 32 35 38 41 44 46 49 52 55 58 61 64										
10 km/h Cyc	945 1050 1150 1255 1360 1465 1565 1670 1775 1875 1980 2085 2190 2295 2400										
25 km/h	850 915 980 1045 1110 1175 1240 1305 1370 1465 1560 1655 1750										
30 km/h	820 885 950 1015 1080 1145 1210 1275 1340 1435 1530 1620 1715										
40 km/h	780 840 905 965 1025 1085 1150 1210 1270 1355 1435 1520 1600										
50 km/h	780 840 905 965 1025 1085 1150 1210 1270 1355 1435 1520 1600										
65 km/h	655 720 780 845 905 970 1030 1095 1155 1215 1280 1340 1400										
Stat	1450 1610 1765 1925 2085 2245 2400 2560 2720 2875 3035 3195 3360 3520 3680										

Ø pouces	Description	CAI	e mm	D mm	R' mm	Cdr. mm	Jante(s) recommandée(s)	Jante(s) tolérée(s)	Chambre à air (Code)	Volume interne 75% (litres)	Profond. de sculpture (mm)
18	340/80R18 IND 143A8/138D TL <i>12.5/80 R18</i>	698283	352	1000	453	3094	11	W10 W11 12 11SDC 12SDC	444 828	106	21
Bar	1.6 1.8 2 2.2 2.4 2.6 2.8 3 3.2 3.4 3.6 3.8 4 4.2 4.4										
Psi	23 26 29 32 35 38 41 44 46 49 52 55 58 61 64										
10 km/h Cyc	1600 1780 1955 2135 2310 2490 2670 2845 3025 3200 3380 3555 3735 3915 4090										
25 km/h	1450 1580 1715 1845 1975 2105 2240 2370 2500 2630 2765 2895 3025										
30 km/h	1390 1520 1645 1775 1900 2030 2155 2285 2410 2535 2665 2790 2915										
40 km/h	1320 1435 1550 1665 1780 1895 2010 2125 2240 2360 2485 2605 2725										
50 km/h	1320 1440 1560 1680 1800 1915 2035 2155 2275 2390 2500 2615 2725										
65 km/h	1135 1235 1340 1440 1545 1645 1745 1850 1950 2045 2145 2240 2335										
Stat	2450 2725 2995 3270 3540 3815 4090 4360 4635 4905 5180 5455 5725 6000 6270										

Ø pouces	Description	CAI	e mm	D mm	R' mm	Cdr. mm	Jante(s) recommandée(s)	Jante(s) tolérée(s)	Chambre à air (Code)	Volume interne 75% (litres)	Profond. de sculpture (mm)
24	360/80R24 IND 150A8/145D TL NEW <i>13.6 R24</i>	514449	365	1192	547	3610	DW12	W11	700	150	26
Bar	1.6 1.8 2 2.2 2.4 2.6 2.8 3 3.2 3.4 3.6 3.8 4 4.2 4.4										
Psi	23 26 29 32 35 38 41 44 46 49 52 55 58 61 64										
10 km/h Cyc	1970 2190 2405 2625 2840 3060 3280 3495 3715 3930 4150 4370 4590 4805 5025										
25 km/h	1775 1935 2100 2260 2425 2585 2745 2910 3070 3235 3395 3560 3720										
30 km/h	1715 1870 2030 2185 2340 2495 2655 2810 2965 3120 3275 3430 3585										
40 km/h	1625 1770 1920 2065 2210 2355 2505 2650 2795 2935 3075 3210 3350										
50 km/h	1625 1770 1920 2065 2210 2355 2505 2650 2795 2935 3075 3210 3350										
65 km/h	1395 1520 1645 1770 1895 2020 2145 2270 2395 2520 2650 2775 2900										
Stat	3020 3355 3690 4025 4360 4695 5025 5360 5695 6030 6365 6700 7035 7370 7705										

* Se référer aux remarques en fin des tableaux de cette gamme

MICHELIN CROSSGRIP

Caractéristiques & Pression en bar / psi – Charges par pneu en kg*

Ø pouces	Description	CAI	e mm	D mm	R' mm	Cdr. mm	Jante(s) recommandée(s)		Jante(s) tolérée(s)	Chambre à air (Code)	Volume interne 75% (litres)	Profond. de sculpture (mm)
24	400/80R24 IND 156A8/151D TL <i>15.5/180 R24 (Equiv 20PR)</i>	920345	413	1240	567	3747	DW13L	DW14L DW12	703	187	26	
Bar	1.6 1.8 2 2.2 2.4 2.6 2.8 3 3.2 3.4 3.6 3.8 4 4.2 4.4											
Psi	23 26 29 32 35 38 41 44 46 49 52 55 58 61 64											
10 km/h Cyc	2340 2600 2860 3125 3385 3645 3905 4165 4430 4690 4950 5215 5475 5740 6000											
25 km/h	2120 2285 2450 2610 2775 2940 3100 3265 3430 3665 3905 4140 4375											
30 km/h	2060 2225 2385 2550 2710 2875 3035 3200 3360 3590 3825 4055 4290											
40 km/h	1950 2105 2255 2410 2565 2715 2870 3020 3175 3380 3590 3795 4000											
50 km/h	1950 2105 2255 2410 2565 2715 2870 3020 3175 3380 3590 3795 4000											
65 km/h	1640 1785 1930 2075 2225 2370 2515 2660 2805 2965 3130 3290 3450											
Stat	3600 4000 4400 4800 5200 5600 6000 6400 6800 7200 7600 8000 8400 8800 9200											

Ø pouces	Description	CAI	e mm	D mm	R' mm	Cdr. mm	Jante(s) recommandée(s)		Jante(s) tolérée(s)	Chambre à air (Code)	Volume interne 75% (litres)	Profond. de sculpture (mm)
24	460/70R24 IND 159A8/154D TL <i>17.5 LR24 (Equiv 18PR)</i>	304047	475	1246	573	3772	DW15L	14 DW14L TW14L DW16A 16	710	218	26	
Bar	1.6 1.8 2 2.2 2.4 2.6 2.8 3 3.2 3.4 3.6 3.8 4 4.2 4.4											
Psi	23 26 29 32 35 38 41 44 46 49 52 55 58 61 64											
10 km/h Cyc	2570 2855 3140 3425 3710 3995 4280 4565 4850 5135 5420 5705 5990 6275 6560											
25 km/h	2320 2530 2745 2955 3165 3375 3585 3800 4010 4225 4435 4650 4860											
30 km/h	2240 2445 2650 2850 3055 3260 3460 3665 3870 4075 4275 4480 4680											
40 km/h	2120 2310 2505 2695 2885 3075 3270 3460 3650 3830 4015 4195 4375											
50 km/h	2120 2310 2505 2695 2885 3075 3270 3460 3650 3830 4015 4195 4375											
65 km/h	1820 1985 2150 2310 2475 2640 2800 2965 3130 3285 3440 3595 3750											
Stat	3940 4375 4815 5250 5690 6125 6560 7000 7435 7875 8310 8750 9185 9625 10060											

Ø pouces	Description	CAI	e mm	D mm	R' mm	Cdr. mm	Jante(s) recommandée(s)		Jante(s) tolérée(s)	Chambre à air (Code)	Volume interne 75% (litres)	Profond. de sculpture (mm)
24	500/70R24 IND 164A8/159D TL <i>19.5 LR24</i>	875270	513	1292	580	3998	DW16A	DW15L DW16L TW16L	710	266	26	
Bar	1.6 1.8 2 2.2 2.4 2.6 2.8 3 3.2 3.4 3.6 3.8 4 4.2 4.4											
Psi	23 26 29 32 35 38 41 44 46 49 52 55 58 61 64											
10 km/h Cyc	2935 3260 3585 3915 4240 4565 4890 5215 5545 5870 6195 6520 6845 7170 7495											
25 km/h	2650 2890 3135 3375 3620 3860 4100 4345 4585 4830 5070 5315 5555											
30 km/h	2560 2795 3025 3260 3495 3725 3960 4190 4425 4655 4890 5120 5350											
40 km/h	2425 2645 2860 3080 3300 3515 3735 3950 4170 4380 4585 4795 5000											
50 km/h	2425 2645 2860 3080 3300 3515 3735 3950 4170 4380 4585 4795 5000											
65 km/h	2080 2265 2455 2640 2830 3015 3200 3390 3575 3755 3930 4110 4285											
Stat	4505 5005 5505 6000 6500 7000 7500 8000 8495 8995 9495 9995 10495 10995 11495											

* Se référer aux remarques en fin des tableaux de cette gamme

MICHELIN CROSSGRIP

Caractéristiques & Pression en bar / psi – Charges par pneu en kg*

Ø pouces	Description	CAI	e mm	D mm	R' mm	Cdk mm	Jante(s) recommandée(s)	Jante(s) tolérée(s)	Chambre à air (Code)	Volume interne 75% (litres)	Profond. de sculpture (mm)
24	440/80R24 IND 161A8/156D TL <i>16.9 R24 (Equiv 18PR)</i>	131846	447	1314	593	3977	DW14L	14 DW15L	710	234	26
Bar	1.6 1.8 2 2.2 2.4 2.6 2.8 3 3.2 3.4 3.6 3.8 4 4.2 4.4										
Psi	23 26 29 32 35 38 41 44 46 49 52 55 58 61 64										
10 km/h Cyc	2710 3010 3315 3615 3920 4220 4525 4825 5125 5430 5730 6035 6335 6640 6940										
25 km/h	2460 2685 2905 3130 3350 3575 3795 4020 4240 4465 4685 4910 5130										
30 km/h	2370 2585 2800 3015 3230 3445 3660 3875 4090 4305 4520 4735 4950										
40 km/h	2240 2445 2650 2855 3060 3260 3465 3670 3875 4065 4250 4440 4625										
50 km/h	2240 2445 2650 2855 3060 3260 3465 3670 3875 4065 4250 4440 4625										
65 km/h	1880 2050 2220 2390 2560 2725 2895 3065 3235 3425 3615 3800 3990										
Stat	4160 4625 5085 5550 6010 6475 6940 7400 7865 8325 8790 9255 9715 10180 10640										

Ø pouces	Description	CAI	e mm	D mm	R' mm	Cdk mm	Jante(s) recommandée(s)	Jante(s) tolérée(s)	Chambre à air (Code)	Volume interne 75% (litres)	Profond. de sculpture (mm)
28	400/80R28 IND 158A8/153D TL <i>14.9 R28</i>	219659	412	1354	615	4094	DW13	W12 W13 DW11	821	159	26
Bar	1.6 1.8 2 2.2 2.4 2.6 2.8 3 3.2 3.4 3.6 3.8 4 4.2 4.4										
Psi	23 26 29 32 35 38 41 44 46 49 52 55 58 61 64										
10 km/h Cyc	2500 2775 3055 3330 3605 3885 4160 4435 4710 4990 5265 5545 5820 6100 6375										
25 km/h	2255 2460 2665 2870 3075 3280 3485 3690 3895 4100 4310 4515 4720										
30 km/h	2175 2375 2570 2770 2970 3165 3365 3560 3760 3955 4150 4350 4545										
40 km/h	2060 2245 2430 2615 2805 2990 3175 3360 3545 3720 3900 4075 4250										
50 km/h	2060 2245 2430 2615 2805 2990 3175 3360 3545 3720 3900 4075 4250										
65 km/h	1770 1930 2090 2245 2405 2565 2725 2880 3040 3190 3345 3495 3645										
Stat	3830 4255 4680 5105 5530 5955 6375 6800 7225 7650 8075 8500 8925 9350 9775										

Ø pouces	Description	CAI	e mm	D mm	R' mm	Cdk mm	Jante(s) recommandée(s)	Jante(s) tolérée(s)	Chambre à air (Code)	Volume interne 75% (litres)	Profond. de sculpture (mm)
28	440/80R28 IND 163A8/158D TL <i>16.9 R28 (Equiv 18PR)</i>	439765	450	1410	635	4283	DW14L	DW15L	822	259	26
Bar	1.6 1.8 2 2.2 2.4 2.6 2.8 3 3.2 3.4 3.6 3.8 4 4.2 4.4										
Psi	23 26 29 32 35 38 41 44 46 49 52 55 58 61 64										
10 km/h Cyc	2850 3275 3700 4125 4550 4975 5400 5825 6250 6675 7100 7525 7950										
25 km/h	2620 2855 3090 3325 3565 3800 4035 4270 4505 4730 4960 5185 5410										
30 km/h	2525 2750 2975 3200 3425 3645 3870 4095 4320 4545 4770 4990 5215										
40 km/h	2360 2570 2780 2990 3200 3405 3615 3825 4035 4245 4455 4665 4875										
50 km/h	2360 2570 2780 2990 3200 3405 3615 3825 4035 4245 4455 4665 4875										
65 km/h	2035 2210 2390 2565 2745 2920 3095 3275 3450 3650 3850 4050 4250										
Stat	4370 4930 5485 6045 6605 7165 7720 8280 8840 9395 9955 10515 11075 11630 12190										

MICHELIN CROSSGRIP

Caractéristiques & Pression en bar / psi – Charges par pneu en kg*

Ø pouces	Description	CAI	e mm	D mm	R' mm	Cdr. mm	Jante(s) recommandée(s)		Jante(s) tolérée(s)	Chambre à air (Code)	Volume interne 75% (litres)	Profond. de sculpture (mm)
34	440/80R34 IND 159A8/155D TL NEW 16,9 R34	967528	436	1580	720	4700	DW14L		DW15L DW16L	704	296	28
Bar	1.6	1.8	2	2.2	2.4	2.6	2.8	3	3.2	3.4	3.6	
Psi	23	26	29	32	35	38	41	44	46	49	52	
10 km/h Cyc	3270	3610	3945	4280	4615	4940	5265	5590	5915	6240	6565	
25 km/h	2730	2965	3195	3425	3655	3905	4150	4395	4640			
30 km/h	2680	2910	3135	3365	3590	3830	4070	4310	4550			
40 km/h	2575	2795	3015	3235	3450	3685	3915	4145	4375			
50 km/h	2575	2795	3015	3235	3450	3685	3915	4145	4375			
65 km/h	2255	2450	2640	2845	3045	3250	3450	3665	3875			

Ø pouces	Description	CAI	e mm	D mm	R' mm	Cdr. mm	Jante(s) recommandée(s)		Jante(s) tolérée(s)	Chambre à air (Code)	Volume interne 75% (litres)	Profond. de sculpture (mm)
34	480/80R34 IND 164A8/159D TL NEW 18,4 R34	333253	477	1648	743	4900	DW15L		DW16L DW18L	823	362	28
Bar	1.6	1.8	2	2.2	2.4	2.6	2.8	3	3.2	3.4	3.6	
Psi	23	26	29	32	35	38	41	44	46	49	52	
10 km/h Cyc	3645	4065	4485	4905	5325	5690	6050	6415	6775	7140	7500	
25 km/h	3075	3370	3660	3950	4240	4505	4770	5035	5300			
30 km/h	3015	3305	3590	3875	4160	4420	4680	4940	5200			
40 km/h	2900	3175	3450	3725	4000	4250	4500	4750	5000			
50 km/h	2900	3175	3450	3725	4000	4250	4500	4750	5000			
65 km/h	2540	2780	3020	3260	3500	3720	3940	4160	4375			

Ø pouces	Description	CAI	e mm	D mm	R' mm	Cdr. mm	Jante(s) recommandée(s)		Jante(s) tolérée(s)	Chambre à air (Code)	Volume interne 75% (litres)	Profond. de sculpture (mm)
38	480/80R38 IND 166A8/161D TL 18,4 R38	846732	478	1757	791	5293	DW15L		DW16L DW18L	786	416	29
Bar	1.6	1.8	2	2.2	2.4	2.6	2.8	3	3.2	3.4	3.6	
Psi	23	26	29	32	35	38	41	44	46	49	52	
10 km/h Cyc	3865	4305	4745	5185	5625	6015	6400	6790	7175	7565	7950	
25 km/h	3260	3570	3885	4195	4505	4785	5065	5340	5620			
30 km/h	3200	3505	3810	4115	4420	4695	4965	5240	5510			
40 km/h	3075	3370	3665	3955	4250	4515	4775	5040	5300			
50 km/h	3075	3370	3665	3955	4250	4515	4775	5040	5300			
65 km/h	2690	2950	3205	3465	3720	3950	4180	4410	4625			
Stat	5925	6600	7275	7950	8625	9220	9815	10410	11000	11595	12190	

***REMARQUES :**

La pression de gonflage se détermine toujours en fonction de la charge par pneu, de la vitesse et du travail à réaliser.
Nos préconisations ci-dessus sont fournies sous réserve de modifications postérieures à la date de diffusion de ces tableaux (mars 2021).
Les données techniques sont susceptibles d'évoluer sans information préalable.

- Pour usage en dévers >20% : ajouter 0,4 bar.
- Pour usage routier intensif >50% : ajouter 0,4 bar.
- Stat = véhicule immobile
- 10 km/h Cyc: Vitesse maxi 10 km/h avec charge cyclique.



MICHELIN XF

**TOUS LES BÉNÉFICES
DE LA TECHNOLOGIE
RADIALE POUR UNE
GRANDE POLYVALENCE
D'UTILISATION ET UN
CONFORT DE CONDUITE**



CONFORT

- Confort pour l'opérateur
- Organes de la machine préservés



DURÉE DE VIE

- Endurance carcasse éprouvée
- Résistance à l'usure



POLYVALENCE

- Efficacité sur tous les types de terrains



Pelles à pneus

* Vs main competitor Bias tyre

DIMENSIONS

445/70R19.5 173A8/180A2 TL

445/70R22.5 175A8/182A2 TL

MICHELIN XF

Caractéristiques & Pression en bar / psi – Charges par pneu en kg*

Ø pouces	Description	CAI	e mm	D mm	R' mm	Cdr mm	Jante(s) recommandée(s)	Jante(s) tolérée(s)	Chambre à air (Code)	Volume interne 75% (litres)	Profond. de sculpture (mm)
19.5	445/70R19.5 173A8/180A2 TL 18 R19.5	489102	452	1110	499	3331	14.00			165	18
Bar	3.5 3.8 4 4.4 4.8 5.2 5.6 6 6.2 6.4 6.6 6.8 7 7.2 7.5										
Psi	51 55 58 64 64 70 75 81 87 90 93 96 99 102 104 109										
10 km/h	4050 4345 4545 4940 5335 5730 6125 6520 6715 6915 7110 7310 7505 7705 8000										
20 km/h	3585 3850 4025 4375 4725 5075 5425 5775 5950 6125 6300 6475 6650 6825 7085										
30 km/h	3420 3670 3840 4170 4505 4840 5175 5510 5675 5840 6010 6175 6345 6510 6760										
35 km/h	3355 3600 3765 4090 4420 4745 5075 5400 5565 5730 5895 6055 6220 6385 6630										
40 km/h	3290 3530 3690 4010 4335 4655 4975 5295 5455 5615 5780 5940 6100 6260 6500										
Stat	6580 7060 7385 8025 8665 9310 9950 10595 10915 11235 11555 11875 12200 12520 13000										

Ø pouces	Description	CAI	e mm	D mm	R' mm	Cdr mm	Jante(s) recommandée(s)	Jante(s) tolérée(s)	Chambre à air (Code)	Volume interne 75% (litres)	Profond. de sculpture (mm)
22.5	445/70R22.5 175A8/182A2 TL 18 R22.5	073522	452	1192	539	3582	14.00			191	20
Bar	3.5 3.8 4 4.4 4.8 5.2 5.6 6 6.2 6.4 6.6 6.8 7 7.2 7.5										
Psi	51 55 58 64 64 70 75 81 87 90 93 96 99 102 104 109										
10 km/h	4300 4615 4825 5245 5665 6085 6505 6925 7135 7345 7555 7765 7975 8185 8500										
20 km/h	3805 4085 4270 4640 5010 5385 5755 6125 6315 6500 6685 6870 7055 7240 7520										
30 km/h	3635 3900 4080 4435 4785 5140 5495 5850 6030 6205 6380 6560 6735 6915 7180										
35 km/h	3560 3820 3995 4345 4690 5040 5385 5735 5910 6085 6255 6430 6605 6780 7040										
40 km/h	3490 3745 3915 4255 4600 4940 5280 5620 5790 5960 6135 6305 6475 6645 6900										
Stat	6980 7490 7835 8515 9195 9880 10560 11245 11585 11925 12265 12605 12950 13290 13800										

***REMARQUES :**

La pression de gonflage se détermine toujours en fonction de la charge par pneu, de la vitesse et du travail à réaliser.
 Nos préconisations ci-dessus sont fournies sous réserve de modifications postérieures à la date de diffusion de ces tableaux (mars 2021).
 Les données techniques sont susceptibles d'évoluer sans information préalable.

- Pour usage en dévers >20% : ajouter 0,4 bar.
- Pour usage routier intensif >50% : ajouter 0,4 bar.
- Stat = véhicule immobile



MICHELIN XM 47

**UN CONFORT ÉLEVÉ SUR
LA ROUTE ET UNE BONNE
ADHÉRENCE HORS ROUTE**



VITESSE

- Possibilité de déplacement à vitesse soutenue (jusqu'à 90km/h)



ROBUSTESSE

- Structure renforcée



DURÉE DE VIE

- Endurance carcasse éprouvée



DIMENSIONS

405/70R20 136G TL

425/75R20 148G TL

445/70R24 151G TL

495/70R24 155G TL

MICHELIN XM 47

Caractéristiques & Pression en bar / psi – Charges par pneu en kg*

Ø pouces	Description	CAI	e mm	D mm	R' mm	Cdr mm	Jante(s) recommandée(s)		Jante(s) tolérée(s)	Chambre à air (Code)	Volume interne 75% (litres)	Profond. de sculpture (mm)			
20	405/70R20 136GTL	123708	395	1076	482	3194	11		W10 11SDC	664	137	28			
Bar	1	1.2	1.6	1.8	2	2.2	2.4	2.6	2.8	3	3.2	3.4	3.6	3.8	4.1
Psi	15	17	23	26	29	32	35	38	41	44	46	49	52	55	59
10 km/h	1400	1570	1910	2080	2250	2420	2590	2755	2925	3095	3265	3435	3605	3775	4030
30 km/h	970	1090	1325	1440	1560	1680	1795	1915	2035	2150	2270	2385	2505	2625	2800
40 km/h	900	1010	1225	1335	1440	1550	1660	1765	1875	1985	2090	2200	2310	2415	2580
65 km/h	850	950	1155	1260	1360	1460	1565	1665	1765	1870	1970	2075	2175	2275	2430
90 km/h	780	875	1065	1155	1250	1345	1440	1535	1630	1720	1815	1910	2005	2100	2240
Stat	1950	2185	2655	2890	3125	3365	3600	3835	4070	4305	4540	4775	5010	5245	5600

Ø pouces	Description	CAI	e mm	D mm	R' mm	Cdr mm	Jante(s) recommandée(s)		Jante(s) tolérée(s)	Chambre à air (Code)	Volume interne 75% (litres)	Profond. de sculpture (mm)			
20	425/75R20 148GTL	123706	450	1147	509	3398	13		11 11SDC 13SDC	664	185	30			
Bar	1	1.2	1.6	1.8	2	2.2	2.4	2.6	2.8	3	3.2	3.4	3.6	3.8	4.1
Psi	15	17	23	26	29	32	35	38	41	44	46	49	52	55	59
10 km/h	1970	2210	2685	2925	3165	3400	3640	3880	4120	4355	4595	4835	5075	5310	5670
30 km/h	1370	1535	1865	2035	2200	2365	2530	2695	2860	3030	3195	3360	3525	3690	3940
40 km/h	1260	1410	1715	1870	2020	2175	2325	2480	2630	2785	2935	3085	3240	3390	3620
65 km/h	1190	1335	1620	1765	1910	2055	2195	2340	2485	2630	2775	2915	3060	3205	3420
90 km/h	1100	1230	1495	1630	1760	1895	2025	2160	2290	2425	2555	2685	2820	2950	3150
Stat	2750	3080	3740	4075	4405	4735	5065	5395	5725	6055	6385	6720	7050	7380	7875

Ø pouces	Description	CAI	e mm	D mm	R' mm	Cdr mm	Jante(s) recommandée(s)		Jante(s) tolérée(s)	Chambre à air (Code)	Volume interne 75% (litres)	Profond. de sculpture (mm)			
24	445/70R24 151GTL	123642	462	1239	562	3689	DW15L		DW14L W14L W15L	710	210	34			
Bar	1	1.2	1.6	1.8	2	2.2	2.4	2.6	2.8	3	3.2	3.4	3.6	3.8	4.1
Psi	15	17	23	26	29	32	35	38	41	44	46	49	52	55	59
10 km/h	2160	2420	2945	3205	3465	3730	3990	4250	4510	4775	5035	5295	5555	5820	6210
30 km/h	1500	1680	2045	2225	2405	2590	2770	2950	3130	3315	3495	3675	3855	4040	4310
40 km/h	1380	1545	1880	2050	2215	2385	2550	2715	2885	3050	3220	3385	3550	3720	3970
65 km/h	1300	1455	1770	1930	2085	2245	2400	2560	2715	2875	3030	3190	3345	3505	3740
90 km/h	1200	1345	1635	1780	1925	2070	2215	2360	2505	2650	2795	2940	3085	3230	3450
Stat	3000	3365	4090	4450	4815	5175	5540	5905	6265	6630	6990	7355	7720	8080	8625

* Se référer aux remarques en fin des tableaux de cette gamme

MICHELIN XM 47

Caractéristiques & Pression en bar / psi – Charges par pneu en kg*

Ø pouces	Description	CAI	e mm	D mm	R' mm	Cdr mm	Jante(s) recommandée(s)		Jante(s) tolérée(s)		Chambre à air (Code)	Volume interne 75% (litres)	Profond. de sculpture (mm)		
24	495/70R24 155G TL	123620	508	1311	581	3883	DW16L		W16L		710	248	35		
Bar	1	1.2	1.6	1.8	2	2.2	2.4	2.6	2.8	3	3.2	3.4	3.6	3.8	4.1
Psi	15	17	23	26	29	32	35	38	41	44	46	49	52	55	59
10 km/h	2430	2725	3310	3605	3900	4190	4485	4780	5070	5365	5660	5955	6245	6540	6980
30 km/h	1690	1895	2300	2505	2705	2910	3115	3315	3520	3720	3925	4130	4330	4535	4840
40 km/h	1550	1740	2115	2300	2490	2675	2865	3050	3240	3425	3615	3805	3990	4180	4460
65 km/h	1460	1635	1990	2165	2345	2520	2695	2875	3050	3230	3405	3580	3760	3935	4200
90 km/h	1350	1515	1840	2005	2165	2330	2495	2655	2820	2980	3145	3310	3470	3635	3880
Stat	3375	3785	4600	5005	5415	5825	6230	6640	7050	7455	7865	8270	8680	9090	9700

***REMARQUES :**

La pression de gonflage se détermine toujours en fonction de la charge par pneu, de la vitesse et du travail à réaliser.

Nos préconisations ci-dessus sont fournies sous réserve de modifications postérieures à la date de diffusion de ces tableaux (mars 2021).

Les données techniques sont susceptibles d'évoluer sans information préalable.

- Pour usage en dévers >20% : ajouter 0,4 bar.
- Pour usage routier intensif >50% : ajouter 0,4 bar.
- Stat = véhicule immobile



MICHELIN BIBSTEEL ALL TERRAIN

**STRUCTURE RADIALE
RENFORCÉE,
MEILLEURE TRACTION,
PAS DE TEMPS MORTS**



CONFORT

- Protection du véhicule et de l'opérateur



TRACTION

- Structure radiale et dessin de la bande de roulement ouvert



ROBUSTESSE

- Structure 100% métallique pour la résistance aux crevaisons



LONGÉVITÉ

- Endurance de la carcasse éprouvée



Chargeur à roues compactes



Télescopiques

DIMENSIONS

210/70R15 IND 117A8/117B TL

260/70R16.5 IND 129A8/129B TL

300/70R16.5 IND 137A8/137B TL

360/70R17.5 IND 148A8/148B TL

MICHELIN BIBSTEEL ALL TERRAIN

Caractéristiques & Pression en bar / psi – Charges par pneu en kg*

Ø pouces	Description	CAI	e mm	D mm	R' mm	Cdk mm	Jante(s) recommandée(s)		Jante(s) tolérée(s)	Chambre à air (Code)	Volume interne 75% (litres)	Profond. de sculpture (mm)				
15	210/70R15 IND 117A8/117B TL <i>27 x 8.50 R15 (Equiv 8PR) Remplace dimension 215/70 R15</i>	085459	209	680	314	2033	7.00				26	15				
	Bar	1.5	1.8	2.2	2.6	3	3.2	3.4	3.6	3.8	4	4.2	4.4	4.6	4.8	5
	Psi	22	26	32	38	44	46	49	52	55	58	61	64	67	70	73
	25 km/h	530	615	720	820	920	970	1020	1070	1125	1175	1225	1275	1330	1380	1430
	40 km/h	475	550	645	740	830	875	920	965	1010	1055	1105	1150	1195	1240	1285
	50 km/h	475	550	645	740	830	875	920	965	1010	1055	1105	1150	1195	1240	1285
	Stat	1100	1270	1485	1695	1905	2010	2115	2220	2325	2430	2535	2640	2745	2850	2955

Ø pouces	Description	CAI	e mm	D mm	R' mm	Cdk mm	Jante(s) recommandée(s)		Jante(s) tolérée(s)	Chambre à air (Code)	Volume interne 75% (litres)	Profond. de sculpture (mm)				
16.5	260/70R16.5 IND 129A8/129B TL <i>10 R16.5 (Equiv 12PR) Remplace dimension 265/70 R16.5</i>	176281	263	774	355	2310	8.25			184	47	20				
	Bar	1.5	1.8	2.2	2.6	3	3.2	3.4	3.6	3.8	4	4.2	4.4	4.6	4.8	5
	Psi	22	26	32	38	44	46	49	52	55	58	61	64	67	70	73
	25 km/h	760	870	1015	1165	1315	1390	1465	1540	1610	1685	1760	1835	1905	1980	2055
	40 km/h	690	785	915	1050	1185	1250	1315	1385	1450	1515	1585	1650	1715	1785	1850
	50 km/h	690	785	915	1050	1185	1250	1315	1385	1450	1515	1585	1650	1715	1785	1850
	Stat	1590	1810	2110	2415	2720	2870	3025	3180	3330	3485	3640	3795	3945	4100	4255

Ø pouces	Description	CAI	e mm	D mm	R' mm	Cdk mm	Jante(s) recommandée(s)		Jante(s) tolérée(s)	Chambre à air (Code)	Volume interne 75% (litres)	Profond. de sculpture (mm)				
16.5	300/70R16.5 IND 137A8/137B TL <i>12 R16.5 (Equiv 14PR)</i>	625787	311	832	380	2481	9.75			184	65	23				
	Bar	1.5	1.8	2.2	2.6	3	3.2	3.4	3.6	3.8	4	4.2	4.4	4.6	4.8	5
	Psi	22	26	32	38	44	46	49	52	55	58	61	64	67	70	73
	25 km/h	970	1095	1270	1450	1630	1720	1810	1905	1995	2090	2180	2275	2365	2460	2550
	40 km/h	875	985	1140	1305	1470	1550	1635	1715	1800	1885	1965	2050	2135	2215	2300
	50 km/h	875	985	1140	1305	1470	1550	1635	1715	1800	1885	1965	2050	2135	2215	2300
	Stat	2010	2270	2630	3005	3380	3565	3755	3950	4140	4330	4525	4715	4905	5100	5290

* Se référer aux remarques en fin des tableaux de cette gamme

MICHELIN BIBSTEEL ALL TERRAIN

Caractéristiques & Pression en bar / psi – Charges par pneu en kg*

Ø pouces	Description	CAI	e mm	D mm	R' mm	Cdr. mm	Jante(s) recommandée(s)		Jante(s) tolérée(s)		Chambre à air (Code)	Volume interne 75% (litres)	Profond. de sculpture (mm)		
17.5	360/70R17.5 IND 148A8/148B TL <i>14 R17.5 (Equiv 14PR)</i>	360353	351	949	429	2823	10.5					99	26		
Bar	1.5	1.8	2.2	2.6	3	3.2	3.4	3.6	3.8	4	4.2	4.4	4.6	4.8	5
Psi	22	26	32	38	44	46	49	52	55	58	61	64	67	70	73
25 km/h	1300	1490	1740	1990	2245	2370	2495	2620	2745	2870	2995	3125	3250	3375	3500
40 km/h	1180	1350	1575	1800	2025	2135	2250	2360	2475	2585	2700	2810	2925	3035	3150
50 km/h	1180	1350	1575	1800	2025	2135	2250	2360	2475	2585	2700	2810	2925	3035	3150
Stat	2715	3105	3620	4140	4660	4920	5175	5435	5695	5955	6215	6475	6730	6990	7250

***REMARQUES :**

La pression de gonflage se détermine toujours en fonction de la charge par pneu, de la vitesse et du travail à réaliser.

Nos préconisations ci-dessus sont fournies sous réserve de modifications postérieures à la date de diffusion de ces tableaux (mars 2021).

Les données techniques sont susceptibles d'évoluer sans information préalable.

- Pour usage en dévers >20% : ajouter 0,4 bar.
- Pour usage routier intensif >50% : ajouter 0,4 bar.
- Stat = véhicule immobile



MICHELIN BIBSTEEL HARD SURFACE

**STRUCTURE RADIALE
RENFORCÉE,
MEILLEURE TRACTION,
PAS DE TEMPS MORTS**



CONFORT

- Protection du véhicule et de l'opérateur



ROBUSTESSE

- Structure 100% métallique pour la résistance aux crevaisons



LONGÉVITÉ

- Endurance de la carcasse éprouvée



Chargeur à roues
compactes



Télescopiques

DIMENSIONS

260/70R16.5 IND 129A8/129B TL

300/70R16.5 IND 137A8/137B TL

MICHELIN BIBSTEEL HARD SURFACE

Caractéristiques & Pression en bar / psi – Charges par pneu en kg*

Ø pouces	Description	CAI	e mm	D mm	R' mm	Cdr. mm	Jante(s) recommandée(s)		Jante(s) tolérée(s)		Chambre à air (Code)	Volume interne 75% (litres)	Profond. de sculpture (mm)
16.5	260/70R16.5 IND 129A8/129B TL 10 R16.5 (Equiv 12PR)	275538	266	773	355	2307	8.25				184	45	18
Bar	1.5 1.8 2.2 2.6 3 3.2 3.4 3.6 3.8 4 4.2 4.4 4.6 4.8 5												
Psi	22 26 32 38 44 46 49 52 55 58 61 64 67 70 73												
25 km/h	760 870 1015 1165 1315 1390 1465 1540 1610 1685 1760 1835 1905 1980 2055												
40 km/h	690 785 915 1050 1185 1250 1315 1385 1450 1515 1585 1650 1715 1785 1850												
50 km/h	690 785 915 1050 1185 1250 1315 1385 1450 1515 1585 1650 1715 1785 1850												
Stat	1590 1810 2110 2415 2720 2870 3025 3180 3330 3485 3640 3795 3945 4100 4255												

Ø pouces	Description	CAI	e mm	D mm	R' mm	Cdr. mm	Jante(s) recommandée(s)		Jante(s) tolérée(s)		Chambre à air (Code)	Volume interne 75% (litres)	Profond. de sculpture (mm)
16.5	300/70R16.5 IND 137A8/137B TL 12 R16.5 (Equiv 14PR)	241265	315	830	378	2477	9.75				184	65	21
Bar	1.5 1.8 2.2 2.6 3 3.2 3.4 3.6 3.8 4 4.2 4.4 4.6 4.8 5												
Psi	22 26 32 38 44 46 49 52 55 58 61 64 67 70 73												
25 km/h	970 1095 1270 1450 1630 1720 1810 1905 1995 2090 2180 2275 2365 2460 2550												
40 km/h	875 985 1140 1305 1470 1550 1635 1715 1800 1885 1965 2050 2135 2215 2300												
50 km/h	875 985 1140 1305 1470 1550 1635 1715 1800 1885 1965 2050 2135 2215 2300												
Stat	2010 2270 2630 3005 3380 3565 3755 3950 4140 4330 4525 4715 4905 5100 5290												

***REMARQUES :**

La pression de gonflage se détermine toujours en fonction de la charge par pneu, de la vitesse et du travail à réaliser.

Nos préconisations ci-dessus sont fournies sous réserve de modifications postérieures à la date de diffusion de ces tableaux (mars 2021).

Les données techniques sont susceptibles d'évoluer sans information préalable.

- Pour usage en dévers >20% : ajouter 0,4 bar.
- Pour usage routier intensif >50% : ajouter 0,4 bar.
- Stat = véhicule immobile



MICHELIN POWER CL

*LE PNEU DIAGONAL (BIAS)
QUI PROPOSE UNE STABILITÉ
À TOUTE ÉPREUVE ET UNE
EXCELLENTE RÉSISTANCE AUX
CHOC / PERFORATIONS*



ROBUSTESSE

- de 6 à 8 nappes carcasses



STABILITÉ

- Excellente stabilité en dévers



DURÉE DE VIE

- Barrettes massives



Tractopelles



Chargeuses



Télescopiques

SIZES

280/80-18 IND 132A8 TL

340/80-18 IND 143A8 TL

280/80-20 IND 133A8 TL

340/80-20 IND 144A8 TL

400/70-20 IND 149A8 TL

400/70-24 IND 158A8 TL

460/70-24 IND 159A8 TL

400/80-24 IND 162A8 TL

500/70-24 IND 164A8 TL

440/80-24 IND 168A8 TL

480/80-26 IND 167A8 TL

440/80-28 IND 163A8 TL

420/80-30 IND 155A8 TL

MICHELIN POWER CL

Caractéristiques & Pression en bar / psi – Charges par pneu en kg*

Ø pouces	Description	CAI	e mm	D mm	R' mm	Cdr mm	Jante(s) recommandée(s)	Jante(s) tolérée(s)	Chambre à air (Code)	Volume interne 75% (litres)	Profond. de sculpture (mm)											
18	280/80-18 IND 132A8 TL <i>10.5/80 - 18 (Equiv 10PR)</i>	281778	288	902	413	2691	9	W9 W10 10 W8	438	80	26											
												Bar	1	1.2	1.6	2	2.4	2.8	3.2	3.6	3.8	4
												Psi	15	17	23	29	35	41	46	52	55	58
												10 km/h	1000	1100	1300	1500	1700	1900	2100	2300	2400	2500
												10 km/h Cyc	1200	1320	1560	1800	2040	2280	2520	2760	2880	3000
												25 km/h	850	935	1105	1275	1445	1610	1780	1950	2035	2120
												30 km/h	830	915	1080	1245	1415	1580	1745	1915	1995	2080
												40 km/h	800	880	1040	1200	1360	1520	1680	1840	1920	2000
												Stat	1840	2025	2390	2760	3130	3495	3865	4230	4415	4600

Ø pouces	Description	CAI	e mm	D mm	R' mm	Cdr mm	Jante(s) recommandée(s)	Jante(s) tolérée(s)	Chambre à air (Code)	Volume interne 75% (litres)	Profond. de sculpture (mm)											
18	340/80-18 IND 143A8 TL <i>12.5/80 - 18 (Equiv 12PR)</i>	610873	353	1006	452	2988	11	W10 W11 12 10 11SDC 12SDC	828 444	106	24											
												Bar	1	1.2	1.6	2	2.4	2.8	3.2	3.6	3.8	4
												Psi	15	17	23	29	35	41	46	52	55	58
												10 km/h	1360	1495	1770	2045	2315	2590	2865	3135	3275	3410
												10 km/h Cyc	1640	1805	2130	2455	2785	3110	3435	3765	3925	4090
												25 km/h	1155	1270	1505	1735	1965	2200	2430	2665	2780	2895
												30 km/h	1130	1245	1470	1695	1925	2150	2375	2605	2715	2830
												40 km/h	1090	1200	1420	1635	1855	2075	2295	2510	2620	2730
												Stat	2510	2760	3260	3765	4265	4765	5265	5770	6020	6270

Ø pouces	Description	CAI	e mm	D mm	R' mm	Cdr mm	Jante(s) recommandée(s)	Jante(s) tolérée(s)	Chambre à air (Code)	Volume interne 75% (litres)	Profond. de sculpture (mm)											
20	280/80-20 IND 133A8 TL <i>10.5/80 - 20 (Equiv 10PR)</i>	694767	287	947	435	2828	9	W8 W9 W10 10	542	86	27											
												Bar	1	1.2	1.6	2	2.4	2.8	3.2	3.6	3.8	4
												Psi	15	17	23	29	35	41	46	52	55	58
												10 km/h	1030	1135	1340	1545	1755	1960	2165	2375	2475	2580
												10 km/h Cyc	1240	1365	1610	1855	2105	2350	2595	2845	2965	3090
												25 km/h	870	960	1135	1310	1485	1660	1835	2010	2095	2185
												30 km/h	860	945	1115	1285	1455	1630	1800	1970	2055	2140
												40 km/h	820	905	1070	1235	1400	1565	1730	1895	1975	2060
												Stat	1900	2090	2470	2845	3225	3605	3985	4360	4550	4740

* Se référer aux remarques en fin des tableaux de cette gamme

MICHELIN POWER CL

Caractéristiques & Pression en bar / psi – Charges par pneu en kg*

Ø pouces	Description	CAI	e mm	D mm	R' mm	Cdr mm	Jante(s) recommandée(s)		Jante(s) tolérée(s)	Chambre à air (Code)	Volume interne 75% (litres)	Profond. de sculpture (mm)											
20	340/80-20 IND 144A8 TL <i>12.5/80 - 20 (Equiv 12PR)</i>	495503	337	1045	474	3112	11		W10 W11 12 10 11SDC 12SDC	664 444	113	25											
													Bar	1	1.2	1.6	2	2.4	2.8	3.2	3.6	3.8	4
													Psi	15	17	23	29	35	41	46	52	55	58
													10 km/h	1400	1540	1820	2100	2380	2660	2940	3220	3360	3500
													10 km/h Cyc	1680	1850	2185	2520	2855	3190	3530	3865	4030	4200
													25 km/h	1185	1305	1540	1780	2020	2255	2495	2730	2850	2970
													30 km/h	1160	1275	1510	1745	1975	2210	2445	2675	2795	2910
													40 km/h	1120	1230	1455	1680	1905	2130	2350	2575	2690	2800
													Stat	2580	2835	3350	3865	4380	4895	5410	5925	6185	6440

Ø pouces	Description	CAI	e mm	D mm	R' mm	Cdr mm	Jante(s) recommandée(s)		Jante(s) tolérée(s)	Chambre à air (Code)	Volume interne 75% (litres)	Profond. de sculpture (mm)											
20	400/70-20 IND 149A8 TL <i>16.0/70 - 20 / 405/70 - 20 (Equiv 16PR)</i>	346809	405	1065	480	3167	13		14 12 12SDC 13SDC	664	129	29											
													Bar	1	1.2	1.6	2	2.4	2.8	3.2	3.6	3.8	4
													Psi	15	17	23	29	35	41	46	52	55	58
													10 km/h	1630	1790	2115	2440	2765	3090	3410	3735	3900	4060
													10 km/h Cyc	1950	2145	2535	2925	3315	3710	4100	4490	4685	4880
													25 km/h	1380	1520	1795	2070	2345	2620	2895	3170	3305	3445
													30 km/h	1350	1485	1755	2025	2295	2570	2840	3110	3245	3380
													40 km/h	1300	1430	1690	1950	2210	2470	2730	2990	3120	3250
													Stat	2990	3290	3890	4485	5085	5685	6285	6880	7180	7480

Ø pouces	Description	CAI	e mm	D mm	R' mm	Cdr mm	Jante(s) recommandée(s)		Jante(s) tolérée(s)	Chambre à air (Code)	Volume interne 75% (litres)	Profond. de sculpture (mm)																
24	400/70-24 IND 158A8 TL <i>16.0/70 - 24 / 405/70 - 24 (Equiv 20PR)</i>	407878	418	1173	535	3497	DW13		13 14 DW14L	703	165	29																
													Bar	1	1.2	1.6	2	2.4	2.8	3.2	3.6	3.8	4	4.2	4.4	4.6	4.8	5
													Psi	15	17	23	29	35	41	46	52	55	58	61	64	67	70	73
													10 km/h	1790	1965	2320	2670	3025	3375	3730	4080	4260	4435	4610	4785	4965	5140	5315
													10 km/h Cyc	2145	2355	2780	3205	3625	4050	4470	4895	5105	5320	5530	5740	5950	6165	6375
													25 km/h	1515	1665	1965	2265	2560	2860	3160	3460	3610	3760	3905	4055	4205	4355	4505
													30 km/h	1485	1630	1925	2220	2510	2805	3100	3395	3540	3685	3835	3980	4125	4275	4420
													40 km/h	1430	1570	1855	2135	2415	2700	2980	3265	3405	3545	3685	3825	3970	4110	4250
													Stat	3290	3615	4265	4910	5560	6210	6855	7505	7830	8155	8480	8800	9125	9450	9775

* Se référer aux remarques en fin des tableaux de cette gamme

MICHELIN POWER CL

Caractéristiques & Pression en bar / psi – Charges par pneu en kg*

Ø pouces	Description	CAI	e mm	D mm	R' mm	Cdr mm	Jante(s) recommandée(s)	Jante(s) tolérée(s)	Chambre à air (Code)	Volume interne 75% (litres)	Profond. de sculpture (mm)
24	460/70-24 IND 159A8 TL <i>17.5 L - 24 (Equiv 18PR)</i>	474764	457	1241	558	3687	DW15L	14 DW14L DW16L 16	710	217	29
Bar	1	1.2	1.6	2	2.4	2.8	3.2	3.6	3.8	4	
Psi	15	17	23	29	35	41	46	52	55	58	
10 km/h	1875	2115	2595	3075	3555	4030	4510	4990	5230	5470	
10 km/h Cyc	2250	2535	3110	3685	4260	4835	5410	5985	6275	6560	
25 km/h	1590	1795	2200	2605	3015	3420	3825	4235	4435	4640	
30 km/h	1560	1760	2160	2555	2955	3355	3755	4150	4350	4550	
40 km/h	1500	1690	2075	2460	2840	3225	3610	3990	4185	4375	
Stat	3450	3890	4770	5655	6535	7415	8295	9180	9620	10060	

Ø pouces	Description	CAI	e mm	D mm	R' mm	Cdr mm	Jante(s) recommandée(s)	Jante(s) tolérée(s)	Chambre à air (Code)	Volume interne 75% (litres)	Profond. de sculpture (mm)				
24	400/80-24 IND 162A8 TL <i>15.5/80 - 24 (Equiv 20PR)</i>	050267	414	1257	571	3743	DW13	13 14 DW14L	703	187	29				
Bar	1	1.2	1.6	2	2.4	2.8	3.2	3.6	3.8	4	4.2	4.4	4.6	4.8	5
Psi	15	17	23	29	35	41	46	52	55	58	61	64	67	70	73
10 km/h	2000	2195	2590	2985	3380	3775	4165	4560	4760	4955	5150	5350	5545	5745	5940
10 km/h Cyc	2400	2635	3110	3585	4055	4530	5000	5475	5710	5950	6185	6420	6655	6895	7130
10 km/h Cyc Dual	1500	1625	1875	2125	2375	2625	2875	3125	3250	3375	3500	3625	3750	3875	4000
25 km/h	1695	1860	2195	2530	2865	3200	3530	3865	4035	4200	4365	4535	4700	4870	5035
30 km/h	1660	1825	2150	2480	2810	3135	3465	3790	3955	4120	4285	4450	4610	4775	4940
30 km/h FRT	3000	3050	3150	3250	3350	3450	3550	3650	3700	3750	3800	3850	3900	3950	4000
40 km/h	1600	1760	2075	2390	2705	3020	3335	3650	3805	3965	4120	4280	4435	4595	4750
Stat	3680	4045	4770	5495	6220	6945	7670	8395	8755	9120	9480	9845	10205	10570	10930

Ø pouces	Description	CAI	e mm	D mm	R' mm	Cdr mm	Jante(s) recommandée(s)	Jante(s) tolérée(s)	Chambre à air (Code)	Volume interne 75% (litres)	Profond. de sculpture (mm)
24	500/70-24 IND 164A8 TL <i>19.5 L - 24 (Equiv 20PR)</i>	196220	504	1315	588	3903	DW16L	DW15L 16	710	264	29
Bar	1	1.2	1.6	2	2.4	2.8	3.2	3.6	3.8	4	
Psi	15	17	23	29	35	41	46	52	55	58	
10 km/h	2125	2400	2950	3500	4050	4600	5150	5700	5975	6250	
10 km/h Cyc	2550	2880	3540	4200	4860	5520	6180	6840	7170	7500	
25 km/h	1800	2035	2500	2965	3435	3900	4365	4835	5065	5300	
30 km/h	1770	2000	2455	2915	3370	3830	4285	4745	4970	5200	
40 km/h	1700	1920	2360	2800	3240	3680	4120	4560	4780	5000	
Stat	3910	4415	5430	6440	7450	8465	9475	10490	10995	11500	

* Se référer aux remarques en fin des tableaux de cette gamme

MICHELIN POWER CL

Caractéristiques & Pression en bar / psi – Charges par pneu en kg*

Ø pouces	Description	CAI	e mm	D mm	R' mm	Cdr. mm	Jante(s) recommandée(s)		Jante(s) tolérée(s)	Chambre à air (Code)	Volume interne 75% (litres)	Profond. de sculpture (mm)			
24	440/80-24 IND 168A8 TL 16.9 - 24 / 16.5/85 - 24 (Equiv 22PR)	165629	460	1328	596	3944	DW15L		DW13 14 DW14L	710	236	29			
Bar	1	1.2	1.6	2	2.4	2.8	3.2	3.6	3.8	4	4.2	4.4	4.6	4.8	5
Psi	15	17	23	29	35	41	46	52	55	58	61	64	67	70	73
10 km/h	2360	2590	3055	3520	3985	4450	4910	5375	5610	5840	6070	6305	6535	6770	7000
10 km/h Cyc	2830	3110	3665	4225	4780	5335	5895	6450	6730	7010	7285	7565	7845	8120	8400
25 km/h	2005	2200	2595	2990	3380	3775	4165	4560	4755	4955	5150	5345	5540	5740	5935
30 km/h	1960	2155	2540	2925	3310	3695	4085	4470	4660	4855	5050	5240	5435	5625	5820
40 km/h	1890	2075	2445	2820	3190	3560	3930	4300	4485	4675	4860	5045	5230	5415	5600
Stat	4340	4765	5620	6475	7330	8185	9035	9890	10320	10745	11170	11600	12025	12455	12880

Ø pouces	Description	CAI	e mm	D mm	R' mm	Cdr. mm	Jante(s) recommandée(s)		Jante(s) tolérée(s)	Chambre à air (Code)	Volume interne 75% (litres)	Profond. de sculpture (mm)
26	480/80-26 IND 167A8 TL 18.4 - 26 (Equiv 20PR)	226486	504	1417	637	4211	DW16L		DW15L	716	302	28
Bar	1	1.2	1.6	2	2.4	2.8	3.2	3.6	3.8	4		
Psi	15	17	23	29	35	41	46	52	55	58		
10 km/h	2670	2940	3475	4015	4555	5090	5630	6225	6520	6815		
10 km/h Cyc	3210	3530	4175	4820	5465	6105	6750	7465	7820	8175		
25 km/h	2270	2495	2950	3405	3860	4315	4770	5275	5530	5780		
30 km/h	2220	2445	2890	3340	3785	4235	4680	5175	5425	5670		
40 km/h	2140	2355	2785	3215	3640	4070	4500	4975	5215	5450		
Stat	4920	5415	6400	7390	8375	9365	10350	11445	11990	12535		

Ø pouces	Description	CAI	e mm	D mm	R' mm	Cdr. mm	Jante(s) recommandée(s)		Jante(s) tolérée(s)	Chambre à air (Code)	Volume interne 75% (litres)	Profond. de sculpture (mm)
28	440/80-28 IND 163A8 TL 16.9 - 28 / 16.5/85 - 28 (Equiv 18PR)	691578	449	1412	642	4201	DW15L		DW14L DW13	822	259	29
Bar	1	1.2	1.6	2	2.4	2.8	3.2	3.6	3.8	4		
Psi	15	17	23	29	35	41	46	52	55	58		
10 km/h	2375	2615	3090	3570	4045	4525	5000	5550	5820	6095		
10 km/h Cyc	2850	3135	3710	4280	4855	5425	6000	6660	6985	7315		
25 km/h	2015	2215	2620	3025	3430	3835	4240	4705	4940	5170		
30 km/h	1975	2175	2570	2970	3365	3765	4160	4615	4845	5070		
40 km/h	1900	2090	2475	2855	3235	3620	4000	4440	4655	4875		
Stat	4370	4810	5685	6565	7445	8320	9200	10210	10710	11215		

* Se référer aux remarques en fin des tableaux de cette gamme

MICHELIN POWER CL

Caractéristiques & Pression en bar / psi – Charges par pneu en kg*

Ø pouces	Description	CAI	e mm	D mm	R' mm	Cdr mm	Jante(s) recommandée(s)	Jante(s) tolérée(s)	Chambre à air (Code)	Volume interne 75% (litres)	Profond. de sculpture (mm)
30	420/80-30 IND 155A8 TL <i>16.9 - 30 (Equiv 14PR)</i>	577845	432	1432	656	4296	DW15L	DW13 DW14L	754	245	36
Bar	1 1.2 1.6 2 2.4 2.8 3.2										
Psi	15 17 23 29 35 41 46										
10 km/h	2300 2530 2995 3455 3920 4380 4845										
10 km/h Cyc	2760 3040 3595 4150 4705 5260 5815										
25 km/h	1950 2145 2540 2930 3325 3715 4110										
30 km/h	1915 2105 2490 2875 3260 3645 4030										
40 km/h	1840 2025 2395 2765 3135 3505 3875										

***REMARQUES :**

La pression de gonflage se détermine toujours en fonction de la charge par pneu, de la vitesse et du travail à réaliser.

Nos préconisations ci-dessus sont fournies sous réserve de modifications postérieures à la date de diffusion de ces tableaux (mars 2021).

Les données techniques sont susceptibles d'évoluer sans information préalable.

- Pour usage en dévers >20% : ajouter 0,4 bar.
- Pour usage routier intensif >50% : ajouter 0,4 bar.
- Stat = véhicule immobile
- 10 km/h Cyc: Vitesse maxi 10 km/h avec charge cyclique.

ÉQUIVALENCES DIMENSIONNELLES







ÉQUIVALENCES DIMENSIONNELLES				COMPACT LINE MICHELIN									
Jantes	Pouces	Millimétriques 1	Millimétriques 2	XMCL XM27	BIBLOAD Hard Surface	CROSSGRIP	XM47	POWER CL	BIBSTEEL Hard Surface	BIBSTEEL All Terrain	TWEEL Hard Surface	TWEEL All Terrain	XF
15	27x8.5 R 15	210/70 R 15	215/70 R 15							X			
16	7.5 R 16	250/80 R 16				X							
	11 LR 16			X									
16,5	10 R 16.5	260/70 R 16.5	265/70 R 16.5						X	X	X		
	12 R 16.5	300/70 R 16.5	305/70 R 16.5						X	X	X	X	
17,5	14 R 17.5	360/70 R 17.5								X			
18	10.5/80 R 18	280/80 R 18		X				X					
	12.5/80 R 18	340/80 R 18	335/80 R 18	X	X	X		X					
		400/70 R 18	405/70 R 18	X	X								
19,5	18 R 19.5	445/70 R 19.5											X
20	10.5/80 R 20	280/80 R 20	335/80 R 20	X				X					
	12.5/80 R 20	340/80 R 20		X	X			X					
	14.5 R 20	380/75 R 20	375/75 R 20	X									
	16.0/70 R 20	400/70 R 20	405/70 R 20	X	X		X	X					
	16.5/75 R 20	420/75 R 20	425/75 R 20	X			X						
22,5	18 R 22.5	445/70 R 22.5											X
24	13.6 R 24	360/80 R 24				X							
	16.0/70 R 24	400/70 R 24		X				X					
	15.5/80 R 24	400/80 R 24				X		X					
	16.9 R 24	440/80 R 24		X	X	X		X					
	17.5 LR 24	460/70 R 24	445/70 R 24	X	X	X	X	X					
	19.5 LR 24	500/70 R 24	495/70 R 24	X	X	X	X	X					
	21 LR 24	540/70 R 24		X	X								
26	18.4 R 26	480/80 R 26	X	X			X						
28	14.9 R 28	400/80 R 28				X							
	16.9 R 28	440/80 R 28		X	X	X		X					
30	16.9 R 30	420/80 R 30					X						
34	16.9 R 34	440/80 R 34				X							
	18.4 R 34	480/80 R 34				X							
38	18.4 R 38	480/80 R 38				X							

EQUIVALENCES DIMENSIONNELLES POUR PNEUMATIQUES DE LA GAMME CONSTRUCTION

Tout changement de dimension pneumatique doit être accepté par le constructeur du véhicule. Pour les véhicules à 4 roues motrices, il est impératif de prendre en compte le «rapport de pont» et de calculer la prépondérance. Vous devez toujours vous assurer que le pneumatique sélectionné pourra porter la charge maximum autorisée du véhicule, à sa vitesse maximum.

Vérifiez que le pneumatique que vous avez choisi est compatible avec la largeur de la jante et son diamètre au seat. Les informations donnée dans ce tableau sont purement indicatives, toute modification d'un véhicule est faite sous la responsabilité du client. En aucun cas, l'équivalence d'un pneumatique correspond exactement à un profil ou à une dimension donnée.

GAMMES PAR USAGES

USAGES / PNEUS	TECHNOLOGIE								
	RADIALE								DIAGONALE
	XMCL / XM27	BIBLOAD HS	CROSSGRIP	BIBSTEEL HS	BIBSTEEL AT	TWEEL HS	TWEEL AT	XF	POWER CL
 Tractopelles	X	X	X						X
 Chargeuses	X	X	X						X
 Télescopiques	X	X	X	X	X			X	X
 Pelles sur pneus								X	
 Chargeuses sur roues compactes				X	X	X	X		
 Tracteurs	X	X	X						X

NOTES

A series of horizontal dotted lines for writing notes.

AGRICULTURE

GUIDE UTILISATEUR

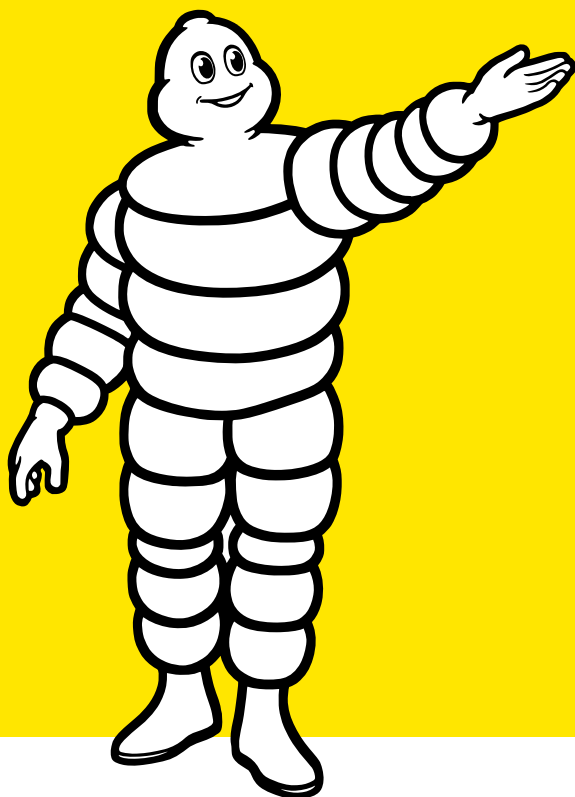

MARS 2021

 [AGRO.MICHELIN.COM](https://www.agro.michelin.com)

 [@MICHELINAGRIFR](https://twitter.com/MICHELINAGRIFR)

 [MICHELIN AGRICULTURE](https://www.youtube.com/MICHELIN AGRICULTURE)

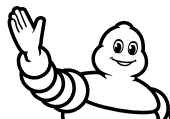

MICHELIN

SOMMAIRE

CHOIX DU PNEU, USAGE ET MISE EN ŒUVRE	3
MARQUAGES DES PNEUMATIQUES	4
INDICES DE CHARGE ET CODES DE VITESSE	5
CONSIGNES DE MISE EN ŒUVRE	6
CALCUL DE PRÉPONDÉRANCE	7
MESURE DYNAMIQUE DE LA PRÉPONDÉRANCE	8
CALCUL DE RÉPARTITION DE CHARGE	9
CALCUL DE RÉPARTITION DE CHARGE	10
RÉFÉRENCES JANTES ET JOINTS TORIQUES	11
RÉFÉRENCES CHAMBRES À AIR ET VALVES	12
CARACTÉRISTIQUES DES VALVES	16
INSTRUCTIONS DE DÉMONTAGE / MONTAGE	18

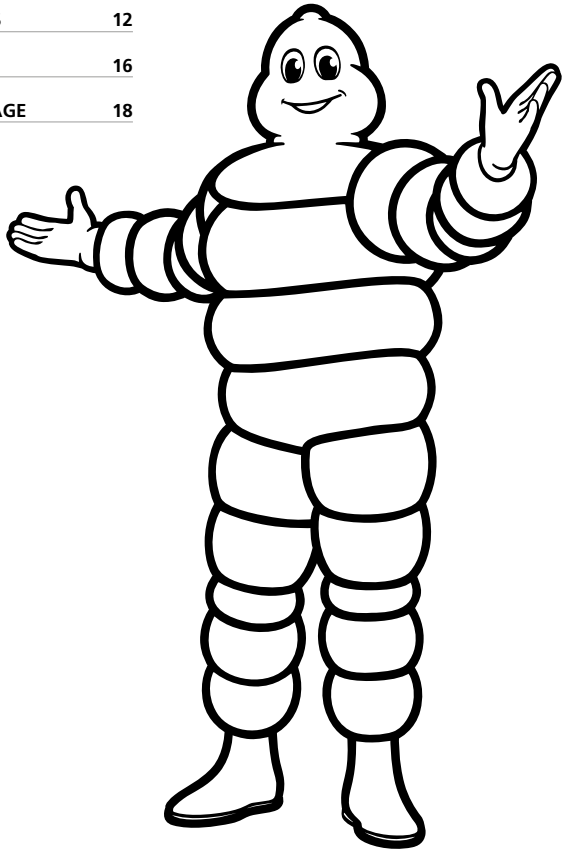

CHOIX DU PNEU, USAGE ET MISE EN ŒUVRE

Le choix d'un pneumatique doit être conforme à la législation et aux équipements préconisés par le constructeur du véhicule, par le fabricant ou par un organisme officiel (dimension, indice de charge et de vitesse, structure (radial, diagonal), etc.).

Il est nécessaire de prendre en compte les conditions d'utilisation du pneumatique afin que les performances de ce dernier répondent aux attentes des utilisateurs.

Dans le cas d'une modification de l'équipement d'origine du véhicule, il convient de vérifier que la solution proposée respecte la législation en vigueur dans le pays (se référer à la réglementation locale), les contraintes et les préconisations du fabricant.

Dans certains pays, le véhicule ainsi modifié doit obtenir une autorisation d'usage.

Les pneumatiques MICHELIN sont conçus pour un usage déterminé.

Tout autre usage constitue un usage anormal.

Toutefois, dans certains cas, Michelin peut autoriser une dérogation qui précisera les conditions et limites d'usage dérogatoires acceptées.

Michelin dégage toute responsabilité en cas d'usage anormal de ses pneumatiques ou en l'absence de toute autorisation dérogatoire expresse et écrite.

Tout pneu d'occasion ou usagé ou ayant été impliqué dans un accident doit faire l'objet, avant son montage, d'une vérification attentive par un professionnel afin de garantir la sécurité de l'utilisateur et le respect de la réglementation en vigueur.

Un mauvais usage ou un mauvais choix de pneumatique peut également contribuer à une usure prématurée de certaines pièces mécaniques.

MARQUAGES DES PNEUMATIQUES

COMMENT LIRE LE MARQUAGE D'UN PNEU ?



XeoBib	Gamme
VF = Very High Flexion	Préfixe désignant une catégorie normalisée de pneus
650	Section nominale du pneu en mm
60	Rapport d'aspect (rapport hauteur flanc/section nominale du pneu) en %
R	Structure : "R" pour radiale "-" pour diagonale
38	Diamètre nominal de la jante en pouces
155	Indice de charge normalisée (cf page 13)
D	Indice de vitesse normalisée (cf page 13)
Radial	Indication de la structure
Tubeless	Pneu sans chambre à air
Michelin® X®	Marque déposée

COTES DIMENSIONNELLES D'UNE ENVELOPPE

S	Largeur de section du pneu
R'	Rayon avec charge en statique
D	Diamètre extérieur, égal à 2 R
ø	Diamètre de la jante



SCHÉMA DES SÉRIES EN 42" ... ET ÉQUIVALENCE EN 38"



INDICES DE CHARGE ET CODES DE VITESSE

La totalité des pneumatiques comporte une description de service composée de l'indice de capacité de charge (nombre) et le code de vitesse (lettre ou lettre avec chiffre).

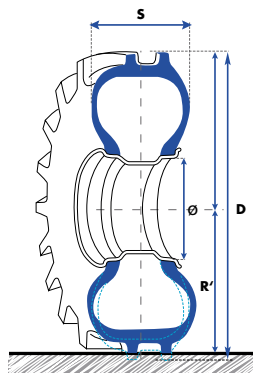
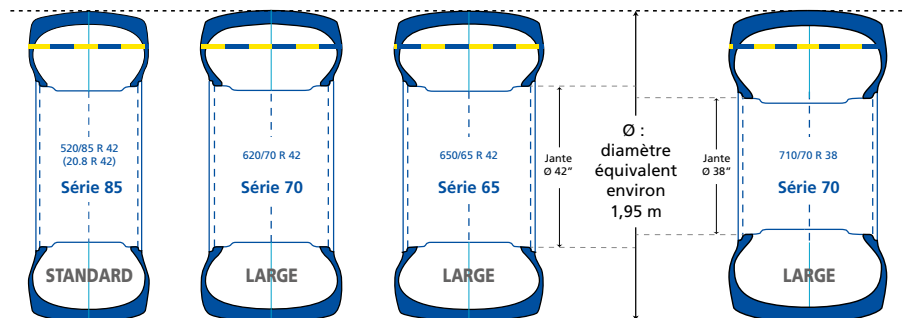
Ci-dessous, les tableaux des indices de charge et codes de vitesse avec l'indication des valeurs correspondantes.

INDICES DE CHARGE

Indice	Charges en kg	Indice	Charges en kg	Indice	Charges en kg	Indice	Charges en kg	Indice	Charges en kg	Indice	Charges en kg
101	825	117	1285	133	2060	149	3250	165	5150	181	8250
102	850	118	1320	134	2120	150	3350	166	5300	182	8500
103	875	119	1360	135	2180	151	3450	167	5450	183	8750
104	900	120	1400	136	2240	152	3550	168	5600	184	9000
105	925	121	1450	137	2300	153	3650	169	5800	185	9250
106	950	122	1500	138	2360	154	3750	170	6000	186	9500
107	975	123	1550	139	2430	155	3875	171	6150	187	9750
108	1000	124	1600	140	2500	156	4000	172	6300	188	10000
109	1030	125	1650	141	2575	157	4125	173	6500	189	10300
110	1060	126	1700	142	2650	158	4250	174	6700	190	10600
111	1090	127	1750	143	2725	159	4375	175	6900	191	10900
112	1120	128	1800	144	2800	160	4500	176	7100	192	11200
113	1150	129	1850	145	2900	161	4625	177	7300	193	11500
114	1180	130	1900	146	3000	162	4750	178	7500	194	11800
115	1215	131	1950	147	3075	163	4875	179	7750	195	12150
116	1250	132	2000	148	3150	164	5000	180	8000	196	12500

CODES DE VITESSE

Code	Vitesse en km/h
A2	10
A5	25
A6	30
A8	40
B	50
D	65
E	70
F	80
G	90
J	100

UNITÉS DE MESURE

1 centimètre	cm	= 0.3937 inch	1 pouce (inch)	in	= 2.54 cm
1 mètre	m	= 3.281 feet	1 pied (foot)	ft	= 0.3048 m
1 kilomètre	km	= 0.6214 mile	1 mile	ml	= 1.6093 km
1 litre	l	= 0.2199754 imp gallon	1 imp. Gallon	imp. gall.	= 4.545963 litres
1 kilogramme	kg	= 2.204622 pounds	1 livre (pound)	lb	= 0.4535924 kg
1 cheval vapeur	cv	= 735.499 W	1 kilowatt	kw	= 1.3596216173 cv
1 bar	bar	= 14.5037738 psi	1 bar	bar	= 100 kPa (kilo Pascal)
1 pound per square inch	psi	= 6.89476 kPa	1 Acre imp.		= 0.4046842 ha
1 hectare	ha	= 2.4711 acre imp.	1 square inch (imp.)	sq in	= 6.451578 cm2
1 centimètre carré	cm2	= 0.1550 sq.in (imp.)	1 tonne	t	= 0.9842064 tn (imp)
1 ton (imp)	tn	= 1.016047	1 kilomètre/heure	km/h	= 0.62137 mph
1 mile per hour	mph	= 1.609344 km/h			

CONSIGNES DE MISE EN ŒUVRE

■ DÉTERMINER LA PRESSION DE GONFLAGE

- La pression de gonflage se détermine toujours en fonction de la charge par pneu, de la vitesse d'usage et du travail à réaliser.
- La charge à prendre en compte est la plus élevée :

Pour les tracteurs :

- essieu avant : tracteur avec ses masses / outil à l'avant en position de transport et sans charge sur l'essieu arrière
 - essieu arrière : tracteur avec outil en position de transport.
- NB :** pour tracteur équipé de chargeur frontal, considérer avec charge maxi sur chargeur.

Pour les engins de récolte : c'est en pleine charge (trémie pleine), avec la barre de coupe (ou cueilleur).

- NB :** pour engins de récolte, déterminer la charge sur essieu :
- avant avec la barre de coupe ou cueilleur
 - arrière sans la barre de coupe ou cueilleur

- Déterminer la pression pour « usage au champ » et « usage sur route » et retenir la plus élevée.
- Dans les cas d'usage routier intensif ou dans les pentes/dévers, suivre les conseils figurant dans les pages « Caractéristiques Techniques des pneus MICHELIN ».

■ EN UTILISATION

- Répartir correctement les charges.
- Adapter sa conduite aux conditions de travail (charge, vitesse, pente, dévers, état de la route / chemin).

■ INFORMATIONS

- Vérifier régulièrement la pression des pneus.
- Vérifier et faire vérifier périodiquement l'état des pneus par un professionnel du pneu, formé et validé
Rappel :
 - Les dommages occasionnés par une crevaison ou un choc peuvent se révéler ultérieurement
 - Les pneus vieillissent même en cas de non-utilisation.
- Pour les réparations, faire appel à un professionnel du pneu, formé et validé.

CALCUL DE PRÉPONDÉRANCE

Le bon fonctionnement des organes de transmission d'un tracteur 4 roues motrices implique le respect de la règle mécanique dite de prépondérance.
Cette règle ne s'applique pas dans le cas de 4 roues de même dimension.

Une prépondérance positive comprise entre 0 et 6% est généralement admise.
Celle-ci est spécifique et peut varier selon le constructeur ou le véhicule.

Une mauvaise prépondérance

- augmente la consommation en carburant,
- accélère l'usure des pneumatiques AV et AR,
- détériore les organes de transmission,
- dégrade le comportement du tracteur lors de certains travaux (labour,...),

et provoque

- un enclenchement brutal du pont AV,
- une perte de puissance et une baisse de rendement,
- une détérioration superficielle du sol.

A noter : Le pont AV ne doit jamais être enclenché sur la route !

Calcul de la prépondérance :

$$\frac{(\text{CdR}_{\text{AV}} \times R) - \text{CdR}_{\text{AR}}}{\text{CdR}_{\text{AR}}} \times 100 = \text{prépondérance en \%}$$

CdR_{AR} : circonférence de roulement du pneumatique Arrière (donnée dans la documentation technique)

CdR_{AV} : circonférence de roulement du pneumatique Avant (donnée dans la documentation technique)

R : rapport de pont (Il est fixé d'origine par le constructeur)

MESURE DYNAMIQUE DE LA PRÉPONDÉRANCE



Mettre des repères sur les roues AV et AR à l'aplomb du sol.

■ ÉTAPE 1

PONT AVANT **NON ENCLENCHÉ**

Pour 10 tours de roue AR,
compter **N** : nombre de tours AV

■ ÉTAPE 2

PONT AVANT **ENCLENCHÉ**

Pour 10 tours de roue AR,
compter **N1** : nombre de tours AV

$$\text{Prépondérance} = \frac{(N1 - N)}{N} \times 100$$

CALCUL DE RÉPARTITION DE CHARGE

MONTE SIMPLE

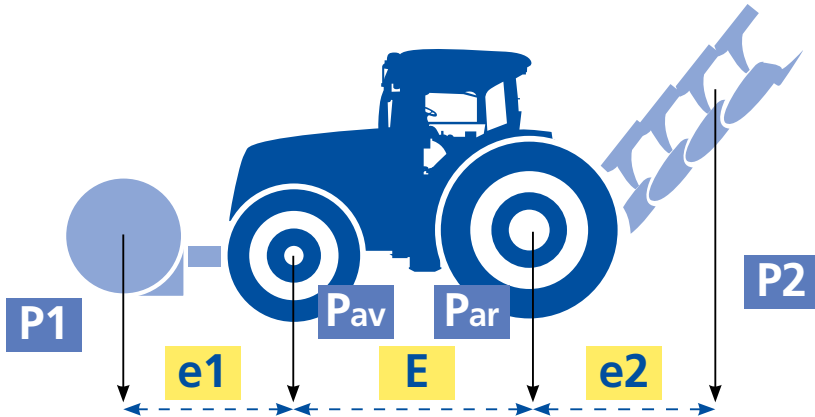

	Essieu Avant (av)	Essieu Arrière (ar)
Tracteur (kg)	P av	P ar
Outil ou masse (kg)	P 1	P 2
Report Outil ou masse (kg)	$P 1 \times (e1/E)$	$P 2 \times (e2/E)$
Total essieu (kg)	$P av + P 1 + [P 1 \times (e1/E)]$	$P ar + P 2 + [P 2 \times (e2/E)]$
Nombre de pneus	N av	N ar
Charge par pneu (kg)	Total essieu av / N av	Total essieu ar / N ar



Flashcode vers l'application de calculateur de pression

Exemples :

Données	Avant	Arrière
Tracteur (kg)	3 000	5 000
Outil ou masse (kg)	1 000	2 000
Distance (mètre)	$E = 3 \text{ m} / e1 = 1,5 \text{ m} / e2 = 2,5 \text{ m}$	

Calcul	Essieu Avant (av)	Essieu Arrière (ar)
Tracteur (kg)	3 000	5 000
Outil ou masse (kg)	1 000	2 000
Report Outil ou masse (kg)	$1\ 000 \times (1,5 / 3) = 500$	$2\ 000 \times (2,5 / 3) = 1\ 666$
Total essieu (kg)	$3\ 000 + 1\ 000 + 500 = 4\ 500$	$5\ 000 + 2\ 000 + 1\ 666 = 8\ 666$
Nombre de pneus	2	2
Charge par pneu (kg)	$4\ 500 / 2 = 2\ 250$	$8\ 666 / 2 = 4\ 333$

CALCUL DE RÉPARTITION DE CHARGE

MONTE EN JUMELÉ * OU EN TRIPLE *

- 1 - Diviser la charge de l'essieu par 4 si en jumelé (ou par 6 si en triple)
- 2 - Puis diviser le résultat obtenu par 0.88 si en jumelé (ou 0.82 si en triple)

* Pour calcul de charge, voir page précédente.

Exemple de calcul pour une monte en jumelé :

- Tracteur en 650/85R38 MICHELIN MACHXBIB 173A8/173B TL
- Charge à l'essieu relevée = 14.000 kg
- Usage = déchaumage

a) Si la ligne Dual à la vitesse souhaitée figure dans le tableau charge / pression :

- diviser la charge totale par 4 (4 pneus)
- utiliser la ligne Dual pour déterminer la pression

b) Si la ligne Dual à la vitesse souhaitée ne figure pas dans le tableau charge / pression :

- diviser la charge totale par 4
- diviser le résultat par 0,88
- utiliser la ligne de la vitesse souhaitée sur le tableau charge/pression

Exemple pour charge totale de 14.000 kg sur essieu arrière en jumelé :

$$[14.000 / 4] / 0,88 = 3.977 \text{ kg}$$

soit un conseil pression à 0,80 bar pour vitesse 30 km/h





NB : en cas de monte en triple, diviser la charge par 6, puis diviser par 0,82 pour obtenir la charge à considérer.

EXEMPLES DE MASSE (KG) PAR M3

	Masse approximative en kg
Paille	100 à 150
Foin	150 à 200
Céréales (blé, maïs, soja...)	600 à 850
Canne à sucre	400
Betterave	900
Pomme de terre	600
Engrais liquide	1300 à 1600
Fumier	900
Terre végétale	1200 à 1500
Sable sec	1500
Sable humide	1900



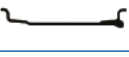

RÉFÉRENCES JANTES ET JOINTS TORIQUES

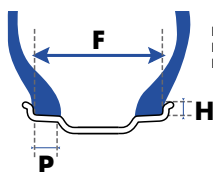
S'assurer que la jante soit compatible en termes de charge et de pression avec l'usage.

Type de jantes	Dimensions	Cote F en mm	Cote H en mm	Cote P en mm
Jante creuse standard 5° 	2.50 C	63,5	16,5	
	3.00 D	76		
	3.50 D	89	18	
	4.00 E	101,5		18
	4.50 E	114,5	20	
	5.00 E	127		23,5
	5.375 I	136,5	16	23
	5.50 F	140		
	6.00 F	152,5	22,5	23,5
6.50 F	165			
Jante base creuse seats coniques 5° 	9	228,5		27
	11	279,5		
	12	305	25,5	
	13	330		31,5
	14	355,5		
16	406,4	25,4		
Jante base creuse seats coniques 15° 	10.50	266,7		
	11.75	298,5		
	12.25	311		
	13.00	330		
	14.00	355,5		
	15.00	381		
	16.00	406,5	12,7	44
	AG 16.00	406,5		
	17.00	432		
	18.00	457		
	20.00	508		
AG 20.00	508			
AG 24.00	609,5			
AG 28.00	711			
Jante SDC 	11	279,5		
	12	305	25,5	
	13	330		
	36.0 TH	914,4	38,1	
	36.00 VA	914,4	43,1	
Jante W 	W 6	152,4		
	W 7	177,8	22,2	23,8
	W 8	203,2		
	W 8L	203,2		
	W 9	228,6	25,4	
	W 10	254		
	W 10L	254	22,2	27
	W 11	279,4		
	W 12	304,8		
	W 13	330,2		
W 14L	355,6	25,4		
W 15L	381			
W 16L	406,4		33	
W 18L	457,2			

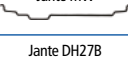

F = Largeur intérieure
H = Hauteur d'accrochage (+/- 1 mm)
P = Largeur du siège

Type de jantes	Dimensions	Cote F en mm	Cote H en mm	Cote P en mm
Jante DW 	DW 10	254		
	DW 11	279,4		27
	DW 12	304,8		
	DW 13	330,2		
	DW 14L	355,6	25,4	36,5
	DW 15L	381		
	DW 16L	406,4		
	DW 17L	431,8		
	DW 18L	457,2		
	DW 20B	508		
	DW 21B	533,4		50,8
	DW 23B	584,2		
	DW 24B	609,5		
	DW 25B	635	28,6	
	DW 27B	686		
DW 28B	711			
DW 30B	762			
Jante TW 	TW 13	330		27
	TW 14L	355,5		
	TW 15L	381	25,5	36,5
	TW 16L	406,5		
	TW 18L	457		
	TW 20B	508		
	TW 21B	533,5		50,8
	TW 23B	584		
	TW 24B	609,5		
	TW 25B	635	29	
TW 27B	686			
TW 28B	711			
TW 30B	762			
Jante DD 	DD 16L	406,5		
	DD 18L	457	41	50,5
Jante MW 	MW 20	508		
	MW 23	584	29	50,8
	MW 25	635		
Jante DH27B 	DH 27B	686	29	54

Lorsque la jante DW est autorisée, la jante TW correspondante l'est aussi (ETRTO)

JOINTS TORIQUES POUR JANTES SDC

Repère	Désignation	Remarque	CAI
R 1681	Joint torique OR 6.6 - 20	Pour jante 20" en 3 pièces	553215
R 1438	Joint torique OR 2 - 25	Pour jante 25" en 3 pièces	553201
R 2052	Joint torique OR 2 - 32	Pour jante 32" en 3 pièces	553055

Pour les joints toriques, la dénomination se fait de la façon suivante :

- OR : abréviation de O Ring (en anglais)
- Le premier nombre désigne la section du joint, c'est un nombre entier dont la valeur est exprimée en 8° de pouce (ex. : 2 = 2/8").
- Le deuxième nombre désigne le diamètre au seat, c'est un nombre entier exprimé en pouces.

RÉFÉRENCES CHAMBRES À AIR ET VALVES

DÉSIGNATION PNEU & JANTE		VALVE		CHAMBRE À AIR KLEBER		CHAMBRE À AIR MICHELIN		CONDITIONNEMENT
Ø JANTE (POUCES)	DIMENSION PNEU	REF. VALVE	VALVE OFFSET	REF. KLEBER	CAI KLEBER	REF. MICHELIN	CAI MICHELIN	
6	3.50 - 4.00	10SC29	0	826	158611			8
8	4.00	10SCH40	0	360	125528			8
12	4.00	TR13	13			12C13	125674	40
	7.00	TR15	25	389	101397			4
15	4.00	TR13	15			15CB13	125682	40
	5.00 - 6.70	TR13	22			15F13	125622	24
15.3	10.0/75 - 11.5/80 - 12.5/80	TR15	80	463	170029			4
16	4.50	TR218A	19	420	101467	M420	834861	4
	5.50 - 6.00	TR15	60	182	170010	M182	884753	4
	6.00 - 6.50	TR218A	60	313	039318	M313	183634	1
	6.50 - 7.00	TR15	65	311	170014			4
	7.50	TR218A	70	431	170000	M431	509471	1
	7.50	TR13	25			16J13	125639	16
	7.50	TR15	70	317	170016	16J15	125669	16
	10.00 - 11.00	TR218A	90	485	170030	M485	410859	1
11LR - 280/70	TR218A	65	184	171108	M184	764859	1	
10.50 - 270/65 - 275/65 - 320/65	TR218A	65	827	813635	M827	030552	1	
16.5	260/70 - 300/70	TR218A	65	184	171108	M184	764859	1
18	7.50	TR218A	70	440	170001	M440	594387	1
	7.50	TR15	70	441	170023			4
	10.5/80 - 280/80 - 260/70 - 280/70 - 270/65	TR218A	70	438	171109	M438	582674	1
	12.0 - 12.5 - 335/80 - 340/80 - 320/65 - 340/65	TR218A	90	444	170025	M444	756917	1
	12.0 - 12.5 - 335/80 - 340/80 - 13.0/65 - 320/65 - 335/65 - 340/65	TR15	80	828	057866	M828	126008	1
19	4.00 - 4.50	TR13	15	446	101417			4
	6.00	TR13	50	449	320346			1
	6.00	TR15	50	452	170026			1
19.5	445/70 (18 R 19.5)	DR1964				19.5/20.5 UD	101280	3

RÉFÉRENCES CHAMBRES À AIR ET VALVES

DÉSIGNATION PNEU & JANTE		VALVE		CHAMBRE À AIR KLEBER		CHAMBRE À AIR MICHELIN		CONDITIONNEMENT	
Ø JANTE (POUCES)	DIMENSION PNEU	REF. VALVE	VALVE OFFSET	REF. KLEBER	CAI KLEBER	REF. MICHELIN	CAI MICHELIN		
20	7.50	TR218A	65	655	170004			1	
	7.50	TR15	60	660	170033			4	
	9.5 - 260/70 - 280/70	TR218A	65	533	171110			1	
	10.00 (Flap)					20x7.50 E	320222	5	
	10.00 (Tube)	582				20N	101162	7	
	10.5 - 11.2 - 280/80 - 300/70 - 320/70	TR218A	90	542	171111			1	
	12.4 - 320/85 - 12.5/80 - 335/80 - 340/80 - 340/75	TR218A	90	444	170025			1	
	12.5 - 14.5 - 14.9 - 335/80 - 340/80 - 340/75 - 375/75 - 380/75 - 420/75 - 425/75 - 360/70 - 400/70 - 405/70 - 420/65 - 440/65	TR218A	90	664	171112			1	
	For 375/75 and 405/70 R 20 on flat rim	750					20RD	101394	5
	For 425/75 R 20 on flat rim	576					20V	511937	1
	For 20" rims in 3 pieces	O-Ring 1681					OR 6.6 - 20	553215	20
20.5	20.5 - 525/65	DR1964	75			19.5/20.5 UD	101280	3	
	24	SC1837	100			20.5W AMD	101331	1	
22.5	600/55	TR218A	90	716	170047			1	
24	8.3 - 9.5 - 250/85	TR218A	70	686	170035			1	
	11.2 - 12.4 - 280/85 - 320/85 - 320/70 - 360/70	TR218A	85	692	170037			1	
	13.6 - 14.5 - 340/85 - 380/70 - 420/65	TR218A	85	700	170039			1	
	14.9 - 380/85 - 400/80 - 400/70 - 420/70 - 440/65	TR218A	127	703	171114			1	
	16.9 - 17.5LR - 19.5LR - 420/85 - 440/80 - 440/70 - 445/70 - 460/70 - 480/70 - 495/70 - 500/70 - 540/70 - 480/65 - 540/65	TR218A	100	710	170042			1	
25	1000/50 - For 25" rims in 3 pieces	O-Ring R 1438				OR 2-25 HEUPO	553201	20	
26	18.4 - 480/80 - VF520/80 - 480/70 - 520/70 - 580/70 - VF620/70	TR218A	90	716	170047			1	
	23.1 - 620/75 - 580/70 - 620/70	TR218A	110	830	823746			1	
	620/70	TR218A	110	717	101447			1	
	750/65	TR218A	160	833	975074			1	



RÉFÉRENCES CHAMBRES À AIR ET VALVES

DÉSIGNATION PNEU & JANTE		VALVE		CHAMBRE À AIR KLEBER		CHAMBRE À AIR MICHELIN		CONDITIONNEMENT
Ø JANTE (POUCES)	DIMENSION PNEU	REF. VALVE	VALVE OFFSET	REF. KLEBER	CAI KLEBER	REF. MICHELIN	CAI MICHELIN	
26.5	600/55	TR218A	90	716	170047			1
	9.5 - 11.2 - 280/85	TR218A	65	725	170050			1
	12.4 - 320/85 - 360/70	TR218A	85	726	170051			1
	13.6 - 340/85 - 380/70 - 420/65	TR218A	85	732	170053			1
28	14.9 - 380/85 - 420/70 - 440/65 - VF480/60	TR218A	85	821	170148			1
	16.9 - 19.5LR - 420/85 - 440/80 - 480/70 - 480/65 - 540/65 - VF520/60 - VF600/60	TR218A	120	822	170149			1
	600/70 - 600/65	TR218A	110	717	101447			1
30	14.9 - 380/85 - 420/70	TR218A	90	734	170054			1
	16.9 - 420/90 - 420/85 - 420/80 - 480/70 - 540/65 - VF540/65	TR218A	95	754	170058			1
	18.4 - 460/85 - 520/70 - VF600/60	TR218A	95	757	170060			1
	23.1 - 520/85 - 620/75 - IF620/75 - VF620/75 - 600/70 - IF600/70 - VF620/70	TR218A	92	737	192251			1
32	8.3 - 9.5 - 210/95 - 230/95	TR218A	70	758	013109			1
	11.2 - 270/95	TR218A	70	763	983325			1
	12.4 - 320/85	TR218A	90	760	877890			1
	24.5 - 30.5 - 680/85 - IF680/85 - 650/75 - 680/75 - 800/70 - IF800/70 - 800/65 - IF800/65 - 900/60 - IF900/60	TR218A	170	831	664520			1
	1000/55 For 32" rims in 3 pieces	O-Ring R 2052					OR 2-32	553055
34	16.9 - 380/85 - VF380/85 - 420/85 - VF420/85 - 480/70 - IF480/70 - 540/65	TR218A	95	704	171115			1
	18.4 - 460/85 - 500/70 - 520/70 - 540/70 - 600/65 - IF650/65 - VF600/60 - IF650/60	TR218A	100	823	170150			1
	24.5 - 710/75	TR218A	180	765	101429			1
36	9.5 - 11.2 - 12.4 - 230/95 - 270/95 - 320/85	TR218A	65	779	170072			1
	13.6 - 340/85	TR218A	80	780	170073			1

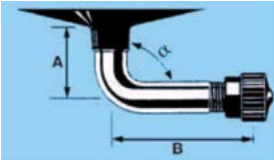
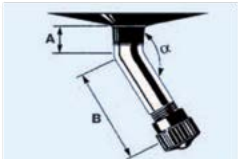
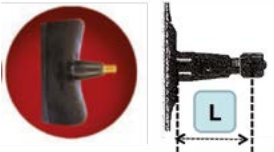
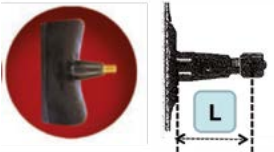

RÉFÉRENCES CHAMBRES À AIR ET VALVES

DÉSIGNATION PNEU & JANTE		VALVE		CHAMBRE À AIR KLEBER		CHAMBRE À AIR MICHELIN		CONDITION- NEMENT
Ø JANTE (POUCES)	DIMENSION PNEU	REF. VALVE	VALVE OFFSET	REF. KLEBER	CAI KLEBER	REF. MICHELIN	CAI MICHELIN	
38	11.2 - 12.4 - 270/95 - 320/85	TR218A	65	779	170072			1
	13.6 - 380/95 - VF380/95 - 340/85 - 380/80 - VF380/80	TR218A	90	795	170079			1
	14.9 - 16.9 - 380/85 - 420/85 - 480/70	TR218A	95	786	170076			1
	15.5 - 380/95 - VF380/95 - 380/80 - VF380/80 - 400/75	TR218A	90	796	118826			1
	18.4 - 460/85 - 520/70 - 540/65 - VF600/60	TR218A	100	824	170151			1
	20.8 - 520/85 - 580/70 - 620/70 - 600/65 - 650/65 - IF650/65 - VF650/60 - IF710/60 - VF710/60	TR218A	105	825	170152			1
	650/85 - IF650/85 - IF710/85 - 650/75 - IF650/75 - IF680/75 - 710/70 - IF800/70	TR218A	105	804	170088			1
42	16.9 - 18.4 - 480/80	TR218A	90	801	170084			1
	20.8 - 520/85 - VF520/85 - 580/85 - VF650/85 - IF710/75 - 620/70 - 710/70 - IF710/70 - 650/65 - VF650/65 - VF710/60	TR218A	140	802	170006			1
44	11.2 - 270/95	TR218A	80	813	440524			1
46	12.4 - 14.9 - 300/95 - 420/85 - 380/80 - VF380/80 - 420/80	TR218A	80	835	203376			1
	18.4 - 20.8 - 520/85 - 480/80 - VF480/80	TR218A	100	834	467962			1
48	9.5 - 11.2 - 230/95 - 270/95	TR218A	80	835	203376			1
50	320/90	TR218A	70	816	170007			1
52	12.4 - 300/95	TR218A	70	816	170007			1
54	11.2 - 270/95 - 320/90	TR218A	70	816	170007			1

CARACTÉRISTIQUES DES VALVES

Dimensions	Type de jantes	Cote F en mm
VALVES CHAMBRE À AIR		
10 SC29		<p>A = 15 mm B = 29 mm $\alpha = 90^\circ$ Ø = trou de valve = 10 mm</p>
10 SCH40		<p>A = 13 mm B = 27 mm $\alpha = 150^\circ$ Ø = trou de valve = 10,2 mm</p>
TR13 (ETRTO = V2-01-1)		<p>L = 35 mm Ø = trou de valve = 11,5 mm</p>
TR15 (ETRTO = V2-01-2)		<p>L = 35 mm Ø = trou de valve = 16 mm</p>
TR218A (ETRTO = V7-01-1) Valve Air / Eau		<p>L = 47,5 mm Ø = trou de valve = 15,7 mm</p>

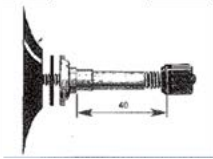
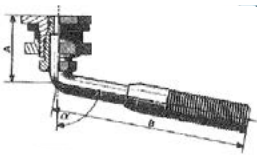
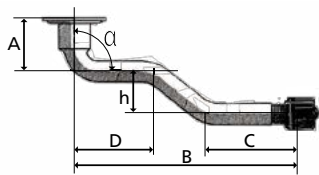
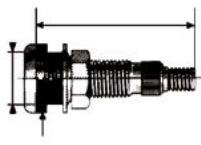
CARACTÉRISTIQUES DES VALVES

Dimensions	Type de jantes	Cote F en mm
VALVES CHAMBRE À AIR		
1964		L = 40 mm Ø = trou de valve = 9,7 mm
1837 Correspondances : • TRA = TRJ650 • ETRTO = V5-04-1		A = 27 mm B = 79 mm $\alpha = 80^\circ$ Ø = trou de valve = 20,5 mm
582 (ETRTO = V3.06.5)		A = 20,5 mm / B = 131 mm C = 49 mm / D = 62,5 mm $\alpha = 90^\circ$ / h = 17 mm
1123 (ETRTO = V3.06.8)		A = 24,5 mm / B = 126,5 mm C = 50,5 mm / D = 61,5 mm $\alpha = 94^\circ$ / h = 17 mm
VALVE TUBELESS		
TR618A (ETRO = V5-01-1) Valve Air / Eau		L = 47,5 mm Ø = trou de valve = 15,7 mm
EMBOUT POUR VALVE AIR / EAU		
		

INSTRUCTIONS DE DÉMONTAGE / MONTAGE

Les opérations de démontage et de montage peuvent présenter des risques, elles doivent être effectuées par un professionnel formé et qualifié, utilisant des outils et des modes opératoires appropriés.

Ne jamais confier cette opération à un apprenti seul ; si ces opérations sont effectuées par plusieurs personnes dans le cas de montage de pneus Grand Volume, s'assurer qu'au moins une même personne soit présente **durant toutes les opérations**.

Le circuit d'air comprimé doit être équipé d'un limiteur de pression.

Le non-respect de ces consignes et modes opératoires peut donner lieu à un montage incorrect du pneu sur la jante et provoquer l'éclatement du pneu, risquant d'entraîner des blessures corporelles graves, voire mortelles.

■ DÉMONTAGE DU PNEU DE LA JANTE

1. **Ne jamais essayer de décoller la jante et/ou les talons d'un pneu gonflé.**
2. **Enlever impérativement le mécanisme intérieur de la valve.**
 - s'assurer que le pneu est complètement dégonflé, avant de procéder au démontage,
 - ne pas utiliser d'outil susceptible de détériorer les flancs ou les talons de l'enveloppe,
 - décoller les talons à partir des encoches de démontage lorsque le pneu en est pourvu,
 - pour faciliter le démontage et protéger les talons, en particulier lors d'une crevaison, lubrifier les sièges de jante et les talons du pneu,
 - si la jante présente des dommages apparents, le dégonflage est un préalable à la dépose de l'ensemble monté.

■ PRÉPARATION AU MONTAGE

1. **Avant montage, s'assurer de la compatibilité entre la jante, le pneu et la chambre à air, et vérifier que :**

- la jante soit compatible en termes de charge et de pression avec l'usage.
- le pneu convienne au véhicule ou à l'engin,
- le diamètre au "seat" de la jante corresponde au diamètre au "seat" du pneu à monter (Exemple : Enveloppe 18.4 R 30 Jante : DW16L x 30),
- le montage du pneu est autorisé sur cette jante (voir caractéristiques dans la documentation du Manufacturier).

**⚠ Ne jamais monter des pneumatiques de 15" sur des jantes de diamètre au seat de 15.3".
Ne jamais monter des pneumatiques de 16" sur des jantes de diamètre au seat de 16.1" et de 16.5".**

2. **Avant de procéder au montage du pneu sur une jante qui a déjà été utilisée :**

- la jante doit être propre, en parfait état et ne présenter aucune détérioration,
- à défaut nettoyer correctement la jante à l'aide d'une brosse métallique.

⚠ Ne jamais monter un pneu sur une jante qui présente des fissures, des déformations importantes, des amorces de rupture, des traces de réparation par soudure...

INSTRUCTIONS DE DÉMONTAGE / MONTAGE

3. Si le pneu est usagé, examiner attentivement l'extérieur et l'intérieur afin de rechercher des détériorations éventuelles.
 - s'il présente une détérioration ou un signe de déchéance jugé non réparable par un spécialiste, éliminer le pneumatique.
4. Pour un montage avec chambre à air, utiliser systématiquement une chambre à air neuve adaptée à la dimension du pneu (marquage sur la chambre à air des dimensions de pneus compatibles).

⚠ Ne pas monter de chambre à air dans une jante détériorée ou réparée ou dans une jante dont la finition ne permet pas de recevoir une chambre.

Monter une valve Tubeless neuve lors de chaque remplacement de pneu Tubeless.

5. Employer toujours des outils en bon état, non tranchants et appropriés aux pneus et aux jantes (décolle bourrelets, leviers, machines...).

Dans le cas de pneus larges ou gros volume, nous conseillons l'utilisation d'un vérin pousse-talon ou d'un décolle bourrelets (assistance mécanique appropriée) pour le montage du deuxième talon.

Avant de procéder au montage, lubrifier les sièges de jante et les bourrelets (talons) de l'enveloppe.

Appliquer une fine couche de lubrifiants sur les parties repérées sur le croquis ci-contre, sur le côté extérieur des bourrelets le lubrifiant doit monter jusqu'à 5 cm plus haut que le rebord de jante.

Utiliser uniquement des produits adaptés à cet usage et non agressifs pour le pneumatique (exclure les produits à base d'hydrocarbures, silicones, antigel...)

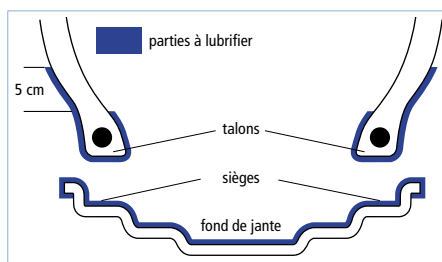

INSTRUCTIONS DE DÉMONTAGE / MONTAGE

MONTAGE VERTICAL DU PNEUMATIQUE SUR LA ROUE

1. Positionner la valve ou le trou de valve en bas.
2. Dans les cas où il existe un dessin de valve sur le flanc du pneu, positionner ce dessin le plus près possible de la valve ou du trou de valve de la jante.
3. Engager le pneu sur la jante de telle sorte que le premier talon du pneu vienne se positionner sur le rebord de jante. Respecter, s'il y a lieu, le sens de rotation indiqué sur le pneu par une flèche.
4. À l'aide d'un levier adapté et par touches successives tous les 10 cm environ :

- faire passer le premier talon par-dessus le rebord de jante.

Une fois le premier talon passé :

- positionner la chambre à air légèrement gonflée à l'intérieur du pneu (cas de montage avec une chambre à air),
- fixer la valve en serrant modérément l'écrou.

Pour le deuxième talon :

- faire passer le talon par-dessus le rebord de jante,
- terminer à la valve.

5. Centrage du pneu, mise en place des talons

- baisser légèrement le cric pour optimiser le centrage du pneu,
- retirer le mécanisme intérieur de la valve,
- gonfler lentement et faiblement pour une meilleure mise en place des talons,
- vérifier que les talons ne pincent pas la chambre à air,
- gonfler à 2,5 bar sans dépasser cette pression, pour assurer une bonne mise en place des talons.

CONFLAGE ET MISE EN PLACE DES TALONS

Appliquer les règles de sécurité :

- système de rétention de l'ensemble pneumatique (cage de sécurité),
- paire de lunettes de protection,
- chaussures de sécurité,
- casque antibruit.

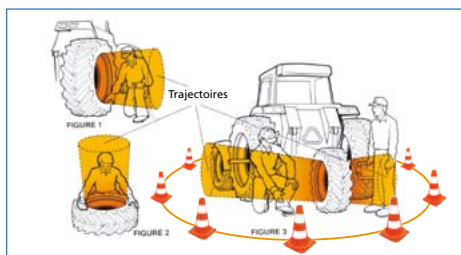

À défaut de cage ou de barre de sécurité, l'opérateur doit s'éloigner le plus possible du pneu et de la jante.

⚠ Ne jamais se placer sur les trajectoires (figures 1, 2, 3) pour éviter tout risque d'accident corporel en cas d'incident.

Pour un travail dans les meilleures conditions de sécurité, utiliser un pistolet de gonflage, relié à la valve par une rallonge d'air de 3 mètres au minimum, équipé d'un système à clip côté valve, avec un manomètre étalonné et en parfait état de marche (ne jamais bloquer la poignée).

Veiller particulièrement à ce que les talons soient bien placés et centrés par rapport aux rebords de jante, gonfler jusqu'à 2,5 bar sans dépasser cette pression, lors de la mise en place des talons.

INSTRUCTIONS DE DÉMONTAGE / MONTAGE

Si les talons ne sont pas correctement en place :

- dégonfler, lubrifier à nouveau et gonfler jusqu'à la pression de 2,5 bar,
- renouveler ces opérations autant de fois que nécessaire jusqu'à la mise en place correcte des talons.

Pour obtenir la montée et la mise en place des talons sur les sièges de la jante
GONFLER À 2,5 BAR SANS DÉPASSER CETTE PRESSION

Le pictogramme ci-contre indique la pression de gonflage maximale à ne pas dépasser pour la mise en place des talons.
Ce pictogramme est représenté sur chaque flanc du pneumatique.

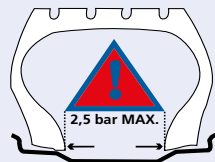

Une fois que toutes les opérations précédentes ont été correctement effectuées

- remettre le mécanisme intérieur de la valve,
- serrer l'écrou de valve à la main,
- gonfler à la pression de service déterminée, en fonction des échelles de charges mentionnées dans la documentation du fabricant ou à la pression de stockage,
- visser le bouchon de valve après toute opération de gonflage ou de contrôle de la pression, car seule cette pièce assure la propreté de la valve et son étanchéité.

En cas de montage à plat au sol, méthode que nous déconseillons du fait de l'impossibilité de voir la mise en place du talon inférieur, prendre les précautions supplémentaires suivantes :

- Ne pas dépasser dans un premier temps la pression maximale de 0,7 bar (pour la prise d'étanchéité),
- Relever impérativement l'ensemble pneu-jante, le placer dans une cage de sécurité ou à défaut appuyer la partie supérieure contre un mur, jamais contre une porte ou une cloison légère,
- Respecter les consignes de gonflage et de mises en place des talons (voir chapitre précédent).

Remarque :

Tous les pneus radiaux utilisés à des pressions basses, imposent que leur montage soit réalisé sur des jantes de qualité.

MISE EN SERVICE DE L'ENGIN / RECOMMANDATIONS

- Pour le transport des engins (par la route, par le rail ou par bateau), nous recommandons de gonfler les pneus à 1,8 bar (26 psi) afin d'éviter des détériorations possibles du fait de certains systèmes d'arrimage.
- À la mise en service de l'engin, les pressions doivent absolument être déterminées et réglées en fonction de la charge supportée par les pneus et des conditions réelles d'utilisation.

INSTRUCTIONS D'UTILISATION Gonflage correct

- =
- ✓ Confort
 - ✓ Adhérence
 - ✓ Respect des sols
 - ✓ Durée de vie des pneus
 - ✓ Rendement optimal de l'engin

INSTRUCTIONS DE DÉMONTAGE / MONTAGE

■ LESTAGE

• Lestage des pneus avec un liquide

Dans certains cas particuliers, pour augmenter le poids adhérent ou abaisser le centre de gravité de l'engin, en Tubeless comme en Tube Type, le lestage des pneus avec du liquide est une solution.

Les valves agricoles sont de type "air et eau". De ce fait le remplissage, à 75% maximum (schéma 1), par du liquide (eau + antigel) est possible.

En hiver, les températures peuvent être inférieures à 0°, donc utilisation obligatoire de produit antigel à base de Glycol.

Remplir de liquide la chambre à air ou le pneu Tubeless, jusqu'à hauteur de la valve (valve placée vers le haut) tout en faisant sortir l'air (schéma 2).

Dans la mesure où Michelin n'est pas impliqué dans la composition de ces produits, la garantie Michelin stipule expressément que Michelin ne sera pas tenu responsable des dommages éventuels causés aux pneus.

Le gonflage et la pression sont ajustés à l'air.

Le volume d'air assurant la pression étant faible (environ 25% du volume), une surveillance régulière de la pression est essentielle, nous préconisons une fréquence de contrôle mensuelle.

• Lestage liquide en Tubeless

- Monter et mettre en place l'enveloppe, voir méthode "Gonflage et mise en place des talons" (page 16),
- Dégonfler le pneu jusqu'à une faible pression (environ 0,5 bar),
- Placer la valve en haut,
- Procéder au lestage de l'enveloppe avec du liquide (eau + antigel) jusqu'à 75% maximum tout en faisant sortir l'air (schéma 2),
- Terminer le gonflage à l'air et ajuster la pression.

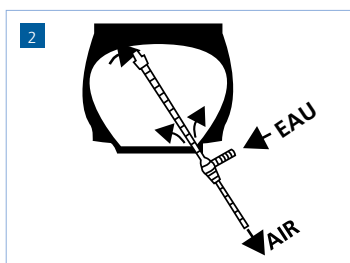
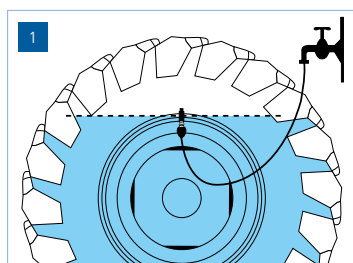

INSTRUCTIONS DE DÉMONTAGE / MONTAGE

■ STOCKAGE

Pour un stockage de qualité, les pneus doivent être conservés en bon état de propreté, dans un local sec et aéré, à l'abri de la lumière directe du soleil. Ils doivent être loin de :

- toute source d'ozone (moteur électrique, transformateur, poste de soudure à l'arc...),
- toute substance chimique, solvants ou hydrocarbures susceptibles d'altérer la nature de la gomme,
- tout corps pouvant pénétrer dans la gomme (objets métalliques pointus ou coupants...).

Éviter la proximité d'une flamme ou d'un corps incandescent.

Durant les périodes de stockage, les pneumatiques et les chambres à air agricoles doivent être conservés de façon à ne pas subir de déformation due à la tension ou à l'écrasement, montés et gonflés s'ils sont en pile, délester au maximum les roues montées sur véhicule et surgonfler de 0,5 bar par rapport à la pression d'usage.

 **Ne jamais stocker pour une longue période des pneus nus ou roues complètes déposées du véhicule, directement en contact avec le sol.**

L'utilisation de gants de protection est recommandée pour leur manutention.

 Ne jamais chauffer, souder ou braser une jante ou une roue avec le pneumatique monté. Toujours démonter d'abord le pneumatique de la jante avant toute intervention.

 Utiliser systématiquement le tableau de gonflage Michelin pour définir la pression correcte pour l'utilisation.

 Le sous-gonflage provoque une déformation exagérée de la carcasse et entraîne une mise hors service prématurée du pneumatique.

 Le surgonflage diminue la surface de contact avec le sol, entraîne une perte d'adhérence et rend l'enveloppe plus sensible aux chocs et aux coupures.

 Si les charges sont inférieures à celles indiquées sur nos tableaux charge pression, ne jamais descendre en dessous de la pression minimale du pneumatique indiquée dans nos tableaux.



AGRICULTURE

GUIDE UTILISATEUR

Manufacture Française des Pneumatiques MICHELIN
Société en commandite par actions au capital de 504 000 004 €
Siège social : place des Carmes-Déchaux, 63040 Clermont-Ferrand cedex 9
Tel.: +33(0)4 73 32 20 00

www.michelin.fr
855 200 507 RCS Clermont-Ferrand

MARS 2021

 AGRO.MICHELIN.COM

 [@MICHELINAGRIFR](https://twitter.com/MICHELINAGRIFR)

 [MICHELIN AGRICULTURE](https://www.youtube.com/MICHELIN AGRICULTURE)



MICHELIN