



PRODUCT BROCHURE

MATERIAL HANDLING
COMPLETE PORTFOLIO



BEYOND ROAD

DIGITAL ENVIRONMENT

We are dedicated to being your best partner, and this also reflects in the online tools we make available. Whether it's through our websites, our social media accounts or digital tools, stay connected to receive the latest updates!

WEBSITES

Developed for those who work and play on a surface that isn't a road, our websites provide information and tools wherever and whenever users need them, no matter what device they're using: a phone, a tablet or a computer.

Product selectors for OTR tires, tracks and track systems for the Construction, Material Handling, Agriculture, and Powersports industries.

Dedicated content such as testimonials, videos, best practices and industry news.

Service and support information including warranty documents, data books and fitment guides.

Contact finder

business.michelinman.com

business.michelin.co.uk | camso.co

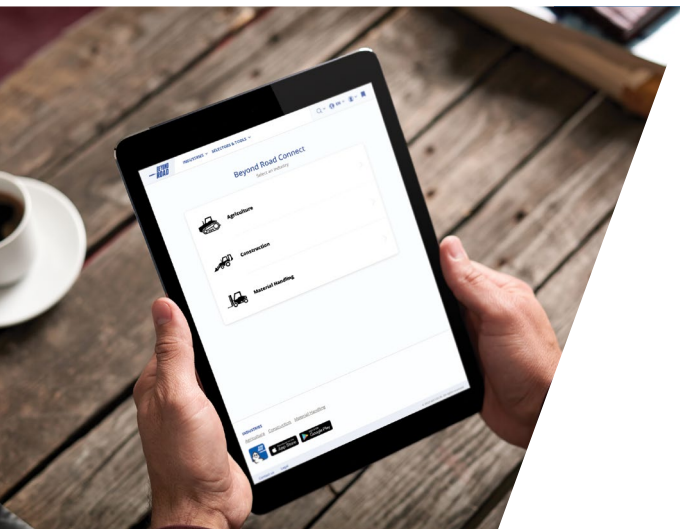
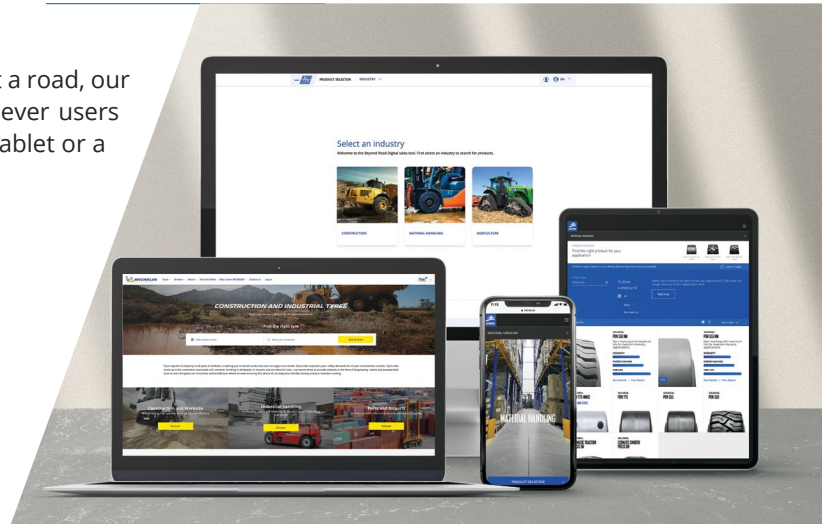

BEYOND ROAD CONNECT

Beyond Road Connect is a tool that helps explaining the features and benefits of our Material Handling, Construction and Agriculture products.

Accessible offline with the [iOS app](#) and [Android app](#).

Complete product information, including features, benefits, product sheets, and customer feedback (voice of customer), etc.

360 views of products and action videos.

Product support information.

Credentials are needed to access the platform, please make sure to create your account by completing [this form](#).

connectbeyondroad.michelingroup.com

USAGE INTENSITY CALCULATOR

Our Usage Intensity Calculator for solid tires helps you select the right product for your application. It will help you measure the work that the tires will perform and help you select the best solution.

intensitycalculator.camso.co

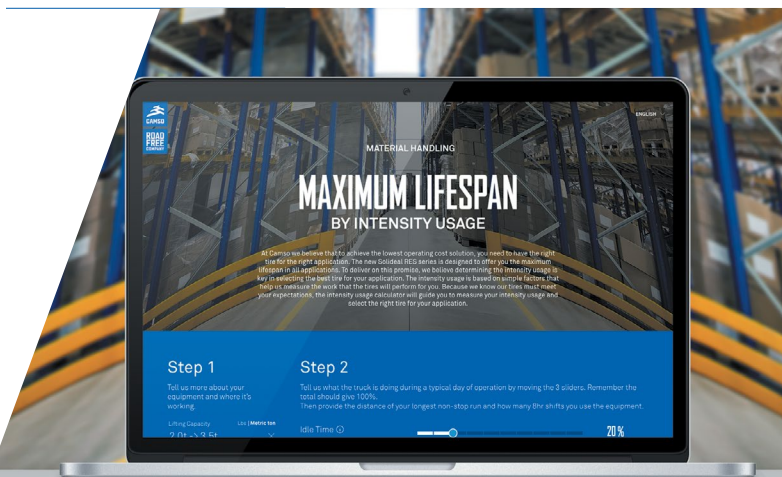



MICHELIN RESERVES THE RIGHT TO CHANGE OR DISCONTINUE ANY SPECIFICATIONS, DESIGNS, FEATURES, MODELS, OR ACCESSORIES SHOWN OR INDICATED WITHOUT NOTICE.

CONNECT WITH US ON SOCIAL MEDIA!

MICHELIN

FACEBOOK
[@MichelinCanada](#)

TWITTER
[@MichelinBiz](#)

LINKEDIN
[@michelin-for-professional-businesses](#)

YOUTUBE
[@michelinearthmover](#)

INSTAGRAM
[@michelinbusiness](#)

CAMSO

FACEBOOK
[@camso.co](#)

TWITTER
[@camso_co](#)

LINKEDIN
[@camso_co](#)

YOUTUBE
[@camoplastsolideal](#)

INSTAGRAM
[@camso_co](#)

TABLE OF CONTENTS

| | | | |
|--|-----------|-----------------------------------|-----------|
| DIGITAL TOOLS | 2 | QUICK HEEL TECHNOLOGY | 44 |
| ABOUT THE BROCHURE | 5 | PRESS-ON TIRES (PON) | 45 |
| FOUR BUSINESS SEGMENTS | 7 | SOLIDEAL PON 775 | 46 |
| COMPLETE LINE OVERVIEW | 11 | SOLIDEAL PON 775 NMAS | 47 |
| INDUSTRIAL PNEUMATIC TIRES (RADIAL) | 14 | SOLIDEAL PON 555 | 48 |
| MICHELIN XZM | 15 | SOLIDEAL PON 555 NM | 49 |
| MICHELIN XZM2+ / XZM2+A | 16 | SOLIDEAL PON 550 | 50 |
| MICHELIN X STACKER 2 | 17 | SOLIDEAL PON 550 NM | 51 |
| MICHELIN X STACKER 3 HD | 18 | SOLIDEAL SM HL | 52 |
| MICHELIN X STRADDLE 2 | 19 | SOLIDEAL SM SRP/SRP+ | 53 |
| MICHELIN X TERMINAL T | 20 | WHEELS & ACCESSORIES | 54 |
| MICHELIN XZR | 21 | SOLIDEAL ON-SITE SERVICE | 57 |
| MICHELIN X AGV EV | 22 | MAINTENANCE TIPS FROM OUR EXPERTS | 59 |
| INDUSTRIAL PNEUMATIC TIRES (BIAS) | 23 | WARRANTY | 62 |
| SOLIDEAL AIR 550 | 24 | | |
| SOLIDEAL ED PLUS NM | 25 | | |
| SOLIDEAL AIR 570 | 26 | | |
| SOLIDEAL HAULER LT | 27 | | |
| SOLIDEAL HAULER SM | 28 | | |
| SOLIDEAL HAULER HA-TR | 29 | | |
| SOLIDEAL PORTMASTER | 30 | | |
| SOLIDEAL AIR 561 | 31 | | |
| RESILIENT TIRES (RES) | 32 | | |
| SOLIDEAL RES 660 XTREME SERIES | 33 | | |
| SOLIDEAL RES XTREME NM | 34 | | |
| SOLIDEAL RES 550 MAGNUM SERIES | 35 | | |
| SOLIDEAL MAGNUM NM | 36 | | |
| SOLIDEAL RES 330 | 37 | | |
| SOLIDEAL RIB | 38 | | |
| SOLIDEAL SOLIDAIR LT | 39 | | |
| SOLIDEAL SOLIDAIR ZZRIB | 40 | | |
| SOLIDEAL HT BOMBER | 41 | | |
| SOLIDEAL SM | 42 | | |
| SOLIDEAL SM SL+ | 43 | | |



ABOUT THE ***BROCHURE***

This Beyond Road Material Handling brochure offers a complete overview of our products and services for every business segment, as well as some maintenance tips, details on warranty and links to our online tools. The brochure showcases the complete Michelin and Solideal material handling product portfolio, and it is available for limited distribution among our dedicated representatives to support sales efforts. The brochure has been designed to be used online or to be printed – whether as a whole or only the desired pages.

WE ARE EXPLORERS, ADVENTURERS AND INNOVATORS, WE ARE MICHELIN BEYOND ROAD.

WHY MICHELIN BEYOND ROAD

As off-the-road mobility specialists, we acknowledge the strong specificity of our customers and offer them relevant off-the-road mobility solutions. Beyond Road means that we'll always look for better ways to partner with our customers to solve their challenges with innovative, relevant and unique products and services.

Our Beyond Road Material Handling team is committed to:

- Go further by providing our customers with trusted off-the-road solutions that make their journey easier, more productive, sustainable and enjoyable.
- Listen, understand and learn about each of our customers' realities.
- Anticipate, collaborate and adapt to create a safer and more efficient work environment.
- Empower ourselves to make responsible decisions in the interests of our partners.
- Pioneer innovative ideas to achieve our sustainability goals.



EFFICIENT AND SAFE MATERIAL HANDLING OPERATIONS

At Michelin Beyond Road, we accelerate your activities for more efficiency. As off-the-road mobility specialists, we developed our expertise in the field, with our clients and partners, understanding and foreseeing the challenges of today's evolving warehousing and logistics, ports operations, and airport ground support handling activities.

Our products are engineered and manufactured with rigorous quality standards to guarantee the safety and reliability of your operations. Be it radial, bias, solid resilient, press-on tires, or wheels, we have the technology and the range to match your needs. You name it,

WE HANDLE IT.



PRODUCTIVITY

Designed to OEM specifications, our tires and wheels ensure smooth, safe operations at the lowest operating cost, providing maximum uptime for your fleets. We can also offer a worldwide service coverage available 24/7, helping you get the job done, on time.



SUSTAINABILITY

With the aim of being a driving force in sustainable mobility, our vision is that by 2050, our tires will be entirely produced with sustainable materials and that every effort will be made, across every industry stakeholder, to ensure that 100% of end of life tires are recycled or reused.



SAFETY

Listening to our clients in the field and investing in research and development helps us ensure our mobility solutions meet and respect safety requirements worldwide. That's how we were able to develop innovative solutions like our non-marking anti-static tires to address the issue of electricity build-up and our TireCare TPMS monitoring solution to avoid unplanned downtime. Furthermore, we work closely with clients to help them understand the impact and risks of tire wear, as well as the importance of selecting the right tire for their specific application.

WE HAVE **4** DEDICATED BUSINESS SEGMENTS

PORT OPERATIONS

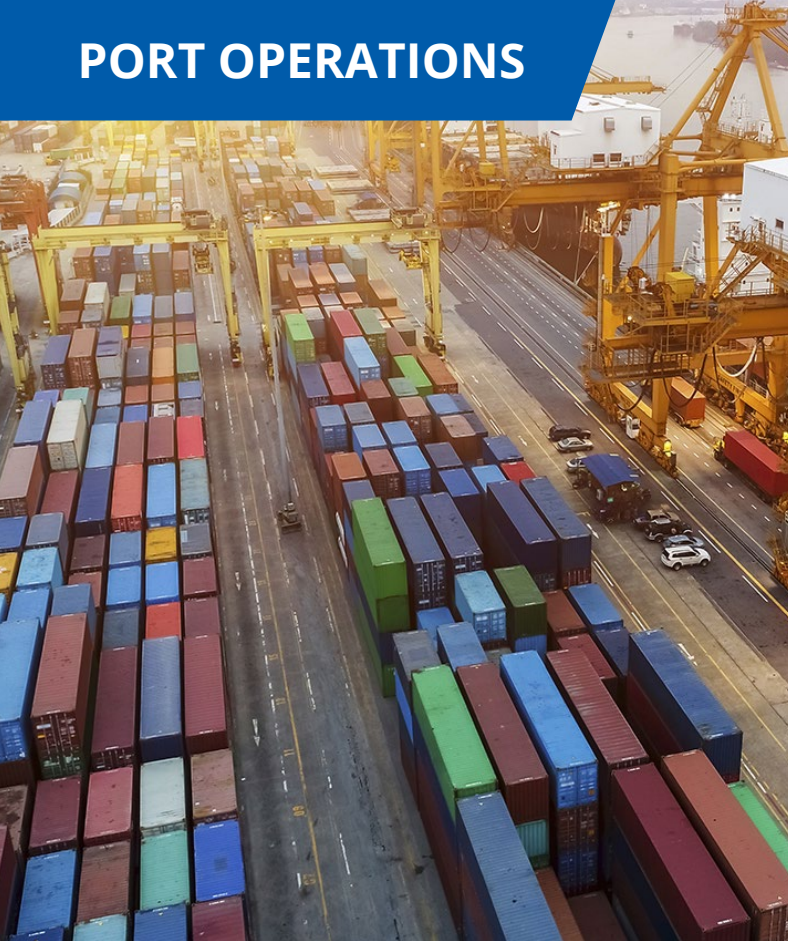

AIRPORT GROUND SUPPORT (GSH)



WAREHOUSING & DISTRIBUTION



MANUFACTURING





[Click here to see video](#)



[Click here to see the line-up by vehicle type](#)

WAREHOUSING & DISTRIBUTION/ MANUFACTURING

To reach the highest productivity levels required for warehousing, distribution, manufacturing and industry operations, we provide the optimal material handling and logistics solutions, no matter the environment or the intensity of your application. Chosen by many of the world's leading OEMs, our tires, wheels and assemblies ensure smooth, safe operations at the lowest operating cost, providing maximum uptime for your fleets.



SMALL CAPACITY FORKLIFT



MULTI-DIRECTIONAL FORKLIFTS



MEDIUM CAPACITY FORKLIFT



SIDELoader FORKLIFTS



ARTICULATED FORKLIFTS



[Click here to see video](#)



[Click here to see the line-up by vehicle type](#)

PORT OPERATIONS

To help you meet today's safety and vessel turnaround time challenges, our experts have developed tires and services specifically adapted to allow you to manage the toughest load and speed requirements, such as straddle carriers with twin lift operations. By creating strong and close relationships with our clients, we also have the ambition of being a key partner in the race for automation and sustainable operations.



AUTOMATIC GUIDED VEHICLES



HEAVY CAPACITY FORKLIFTS



REACH STACKERS



TERMINAL TRACTORS



TERMINAL TRAILERS



EMPTY CONTAINER HANDLERS



LADEN CONTAINER HANDLERS



STRADDLE CARRIERS



[Click here to see video](#)



[Click here to see the line-up by vehicle type](#)

AIRPORT GROUND SUPPORT HANDLING (GSH)

Facing the challenges of your daily activities via a single point of contact, our team provides a tailor-made approach that covers entirely the specific needs of airport ground support handling. From fueling, to aircraft towing or baggage handling, our solutions support operations to ensure a smooth and safe coordination of all ground support activities allowing the aircraft to take off within the strict time constraints.



TOW TRACTORS



CONTAINER/PALLET TRANSPORTERS



PASSENGER BOARDING BRIDGES



BAGGAGE/CARGO TRAILERS AND DOLLIES



BELT LOADERS



AIRCRAFT TRACTORS

COMPLEMENTARY RANGE

Michelin also provides an extensive range of complementary products within the array of airport ground support activities, covering all of your operations' needs.



TRUCKS & BUSES



FIRE TRUCKS



SNOWPLOWS



LIGHT TRUCKS and more

COMPLETE LINE OVERVIEW

INDUSTRIAL PNEUMATIC TIRES | RADIAL



MICHELIN
XZM



MICHELIN
XZM2+ / XZM2+A



MICHELIN
X STACKER 2



MICHELIN
X STACKER 3 HD

NEW



MICHELIN
X STRADDLE 2



MICHELIN
X TERMINAL T



MICHELIN
XZR



MICHELIN
X AGV EV

NEW SIZE

INDUSTRIAL PNEUMATIC TIRES | BIAS



SOLIDEAL
AIR 550



SOLIDEAL
ED + NM



SOLIDEAL
AIR 570



SOLIDEAL
HAULER LT



SOLIDEAL
HAULER SM



SOLIDEAL
HAULER HA-TR



SOLIDEAL
PORTMASTER HD



SOLIDEAL
AIR 561

SOLID TIRES | RESILIENT



SOLIDEAL RES 660
XTREME SERIES



SOLIDEAL
RES XTREME NM



SOLIDEAL RES 550
MAGNUM SERIES



SOLIDEAL
MAGNUM NM



SOLIDEAL
RES 330



SOLIDEAL
RIB



SOLIDEAL
SOLIDAIR LT



SOLIDEAL
SOLIDAIR ZZRIB



SOLIDEAL
HT BOMBER



SOLIDEAL
SM



SOLIDEAL
SM SL+

SOLID TIRES | PRESS-ON



SOLIDEAL
PON 775

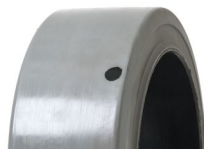

SOLIDEAL
PON 775 NMAS



SOLIDEAL
PON 555



SOLIDEAL
PON 555 NM



SOLIDEAL
PON 550



SOLIDEAL
PON 550 NM



SOLIDEAL
SM HL



SOLIDEAL
SM SRP/SRP+



TIRE ***TECHNOLOGIES***

When it comes to tires, it's all about delivering the right product for the unique mobility challenges of the material handling industry. Could it be pneumatic or solid tires, we have the range to meet the realities of today's evolving material handling applications. Machine requirements have changed – they now on average travel at higher speeds and cover longer distances than ever before. With this, the intensity of their duty cycles is becoming more demanding.

As off-the-road mobility specialists, we understand these nuances. We believe to ensure the lowest operating cost solution you need to have the right tire for your application. So, we engineered a complete portfolio of tires for all types of material handling activities on any surface, could it be in a port, warehouse, airport – you name it, **we handle it.**

INDUSTRIAL PNEUMATIC ***RADIAL TIRES***

Radial tires combine metal or fabric plies, extending from one bead to the other. The radial construction decouples the side walls from the tread. Therefore the tire has a large, low wearing and stable footprint, offering the best traction on all types of surfaces. Also, it has an increased resistance to heating and allows a higher mileage. All of this results in a low cost per hour for the most demanding applications.



MICHELIN XZM

SWITCH FOR A LONGER LIFE IN YOUR INTENSIVE APPLICATIONS



[Click here to see the complete line overview](#)

Robustness

- High resistant metallic crown belt structure with deep and massive tread pattern
- Provides an additional advantage of sidewall protection



Radial technology

- The sidewall and tread function separately
- The crown is stabilized by several plies
- The steel casing has one radial ply

Long tire life

- Outstanding life performance resulting of an improved radial structure associated to a deep and massive tread pattern
- Increase wear life: from +50% to +160% hours in operation⁽¹⁾

DURABLE AND LONG LASTING TIRE THAT SUPPORTS YOUR OPERATIONS THROUGH LOW DOWNTIME AND LOW SERVICE COSTS IN THE MOST DEMANDING APPLICATIONS.

PERFORMANCE INDICATORS

May differ depending on the vehicle your tires are mounted on.

To see the full size list and performance ratings, [click here](#).



POPULAR SIZES

| | |
|----------------------|---------------------|
| 315/70 R 15 TUBELESS | 11.00 R 20 TUBELESS |
| 355/65 R 15 TUBELESS | 12.00 R 20 TUBELESS |
| 9.00 R 20 TUBELESS | 14.00 R 24 TUBELESS |
| 10.00 R 20 TUBELESS | 16.00 R 25 TUBELESS |

⁽¹⁾ Field study in real life conditions made by Michelin for 2 years 2009-2011, on 60 forklifts in Europe (UK/Germany) same tire size and same usage on existing MICHELIN XZM range vs. premium competitors.

MICHELIN XZM2+/XZM2+A

YOUR PRODUCTIVITY
DESERVES MICHELIN



[Click here to see
the complete line
overview](#)

Reduced downtime

- Its massive tread, wear resistance and low abrasion rubber provide exceptional service life

Productivity

- Extra long life for less stops and less servicing



Robustness

- Highly resistant to impact and puncture
- Thanks to the IND5 optimized radial technology, the tire structure is improved and offers rubber sidewall protection

THE MOST VERSATILE OPTION FOR REACH STACKERS.
ITS INCREASED ROBUSTNESS ENABLES YOU TO MAXIMISE YOUR PRODUCTIVITY AND SERVICE LIFE.

PERFORMANCE INDICATORS

May differ depending on the vehicle your tires are mounted on.

To see the tires' performance ratings, [click here](#).



AVAILABLE SIZES

18.00 R 25 TUBELESS (XZM2+A)

18.00 R 33 TUBELESS (XZM2+)

MICHELIN X STACKER 2

MAXIMIZE THE UPTIME
OF YOUR REACH STACKER



[Click here to see
the complete line
overview](#)

More robust

- New and improved crown structure providing a higher endurance
- Superior overall robustness of the tire

Last longer

- +7% extend wear life⁽¹⁾

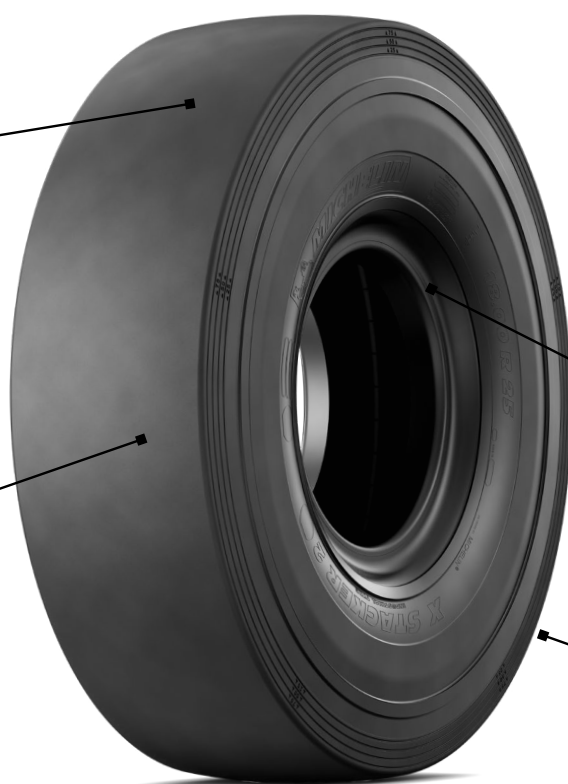

Excellent bead endurance

- Introduction of new Michelin B²® technology

Productivity

- Adapted tread depth to run + 40% distance per hour⁽¹⁾
- A dual compound to run longer distance per hour and for longer wear life

A SMOOTH IND5 RADIAL TIRE THAT PROVIDES EXTRA LONG LIFE FOR STACKING OPERATIONS.
EXCEPTIONAL ROBUSTNESS AND RESISTANCE TO AGRESSIONS.

PERFORMANCE INDICATORS

May differ depending on the vehicle your tires are mounted on.

To see the tires' performance ratings, [click here](#).



AVAILABLE SIZE

18.00 R 25 TUBELESS

As per the 2020 Michelin Databook:

⁽¹⁾ Compared to MICHELIN® X STACKER® 18.00 R 25 tire, average performance by port site. Projected improvement in wear life based on field performance in customer port sites.

MICHELIN X STACKER 3 HD

BOOST YOUR PRODUCTIVITY



[Click here to see the complete line overview](#)

Robustness

- Extra service life in heavy duty conditions⁽²⁾

Tread design innovation

- Interlocking tread racks to limit crown distortion
- Optimized tread wear indicator to secure wear life projection⁽³⁾
- Massive shoulder ribs to improve wear performance



Productivity

- Drive up to 12 km in an hour at 25 km/h ⁽¹⁾

PROTECT YOUR INVESTMENT WITH THE MOST DEPENDABLE TIRE FOR REACH STACKERS.

PERFORMANCE INDICATORS

May differ depending on the vehicle your tires are mounted on.

To see the tires' performance ratings, [click here](#).



AVAILABLE SIZE

18.00 R 25 207 A5 TUBELESS

18.00 R 33 214 A5 TUBELESS

Based on the test performed until 2022:

⁽¹⁾ Compared to MICHELIN® 18.00R25 XZM2+ and X STACKER 2 : respective max distance of 10 and 7 km in one hour at 25 km/h max speed (distance per hour is directly correlated to the amount of tons transportable in an hour). Test method performed in Ladoux: thermal endurance limitation of the tire model structure during transport operation.

⁽²⁾ Compared to XZM2+ and XZM2+A that may be removed with 40% rubber remaining under severe condition. X STACKER 3 HD removed after being 100% worn, resulting in up to 30% extra life time. Data based on quality records, obtained from port operators, between 2017 and 2022.

⁽³⁾ Compared to MICHELIN® 18.00R25 XZM2+/XZM2+A and X STACKER 2 LC. Field study in real life conditions made by Michelin during 7 years in a representative panel of operating terminals in Australia, Europe and Middle East; same size and usages.

MICHELIN X STRADDLE 2

MOVING CONTAINERS
FURTHER AND FASTER



[Click here to see
the complete line
overview](#)

Run longer distances

- Drive up to 15 km in an hour at 25 km/h⁽¹⁾

Higher load capacity at high speeds

- Carry up to 18 tons up to 22 km/h (13 mph) due to + 20% tire inner air volume⁽²⁾



Improved bead design

- Can be fitted on both 11.25 and 13.00 rims⁽⁴⁾ due to a new bead area design

RUN FURTHER

Up to + 15% wear life due to a new tread design with 8% more rubber and an improved crown and bead durability⁽³⁾.

THE SAFEST AND MOST PRODUCTIVE OPTION FOR YOUR STRADDLE CARRIERS.
THE 480/95 R 25 SIZE HAS BEEN SPECIALLY DESIGNED FOR TWIN LIFT OPERATIONS.

PERFORMANCE INDICATORS

May differ depending on the vehicle your tires are mounted on.

To see the tires' performance ratings, [click here](#).



AVAILABLE SIZES

450/95 R 25 TUBELESS

480/95 R 25 TUBELESS

As per the 2020 Michelin Databook:

⁽¹⁾ Compared to MICHELIN X STRADDLE 480/95R25: max distance of 12 kilometers in one hour and 30 mi/h max speed. Characteristic of the product measured with the TKPH indicator. Distance per hour is directly correlated to the amount of tons transportable in an hour.

⁽²⁾ At the nominal pressure of 10 bars and carry 17 Tons from 22km/h to 25km/h. The addition of tire inner volume is compared to MICHELIN X STRADDLE 16.00R25 and MICHELIN X STRADDLE 2 450/95R25 tires.

⁽³⁾ Compared to MICHELIN X STRADDLE 480/95R25, average performance by port site, between 2008-2012. Projected improvement in tire life based on field performance in customer port sites of the MICHELIN X STRADDLE 2 450/95R25 compared to the MICHELIN X STRADDLE 16.00R25, that included individual design improvements incorporated into the MICHELIN X STRADDLE 2 480/95R25.

⁽⁴⁾ Measuring rim: 13.00/2.5 and approved rim: 11.25/2.0.

MICHELIN X TERMINAL T

KEEP YOUR MACHINE ON THE MOVE
AND KEEP YOUR TIRE BUDGET UNDER
CONTROL



[Click here to see
the complete line
overview](#)

Safety and reliability

- High level of transversal and longitudinal grip
- Excellent performance on wet ground
- Tubeless tire
- Anti-static properties



Versatility

- Same size and same tread for all the axles (front and rear)
- Reduction of stocks

Productivity

- Low downtime due to high puncture resistance

THE LEADING SOLUTION IN THE MARKET FOR TERMINAL TRACTORS AND TRAILERS, COMBINING
EXCEPTIONAL PUNCTURE RESISTANCE WITH AN INCREDIBLE LONG LIFE.

PERFORMANCE INDICATORS

May differ depending on the vehicle your tires are mounted on.

To see the tires' performance ratings, [click here](#).



AVAILABLE SIZES

280/75 R 22.5 TUBELESS

310/80 R 22.5 TUBELESS

MICHELIN XZR

A REAL INNOVATION IN TUBELESS TIRE SYSTEMS



[Click here to see
the complete line
overview](#)

Safety

- Exceptional grip for short distance braking
- The radial structure and multi-block pattern provides maximal ground footprint

High speed

- Tread pattern and rubber compounds engineered for cooler running
- Capable of reaching up to 50 km/h (31 mph) under intense usage conditions⁽¹⁾



Longevity and robustness

- Rubber compounds and specific tread pattern allow to maximize lifetime and reduce maintenance requirements
- With steel-belted radial casing instead of usual textile solutions

THE SOLUTION FOR BAGGAGE TRACTORS, URBAN MACHINES AND OTHER SPECIFIC HIGH INTENSITY FORKLIFT USES WITH AN EXCEPTIONAL TOTAL COST OF OWNERSHIP.

PERFORMANCE INDICATORS

May differ depending on the vehicle your tires are mounted on.

To see the tires' performance ratings, [click here](#).



AVAILABLE SIZES

6.00 R 9 TUBELESS

6.50 R 10 TUBELESS

7.00 R 12 TUBELESS

⁽¹⁾ Characteristic of the product measured with the TKPH indicator.

MICHELIN X AGV EV

RELIABILITY YOU CAN
DEPEND ON



[Click here to see
the complete line
overview](#)

Improve service life⁽¹⁾

- Smooth pattern designed with specific rubber compound for an optimized tire life

Energy efficiency

- Specifically designed IND3 structure to ensure minimal rolling resistance, helping customers limiting emissions
- Get up to 40% reduction in rolling resistance⁽²⁾

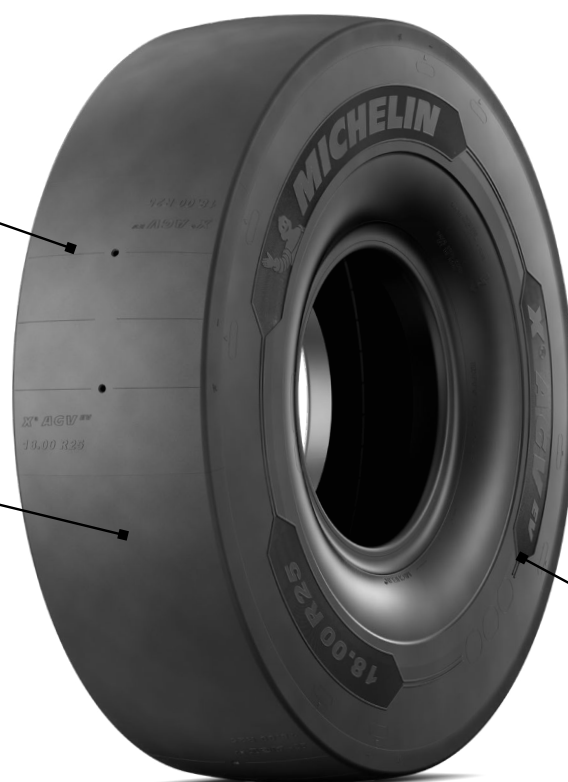

Robustness

- New generation of radial tire, developed to ensure maximal reliability on automated machines

THE MICHELIN X AGV EV IS A NEW GENERATION RADIAL TIRE DESIGNED TO THE SPECIFIC NEEDS OF YOUR AGV OPERATIONS, PROVIDING AN EXTREMELY RELIABLE SOLUTION TO HELP YOU REACH YOUR PRODUCTIVITY TARGETS.

PERFORMANCE INDICATORS

May differ depending on the vehicle your tires are mounted on.

To see the tires' performance ratings, [click here](#).



AVAILABLE SIZES

18.00 R 25 TUBELESS

21.00 R 25 TUBELESS

⁽¹⁾ Expect to be in operations over 20.000 hours / 4 years under standard operation. Tire tested in real conditions, port of Rotterdam, from 2020 to 2021.

⁽²⁾ Compared to premium BIAS and Radial tires on AGV market. Rolling resistance measured in Michelin Center, in Ladoux, from 2020 to 2021.

INDUSTRIAL PNEUMATIC ***BIAS TIRES***

The construction of bias tires (also referred to as diagonal ply tires) includes multiple layers of fabric plies, set one on the other, running diagonally from bead to bead. Their benefits include high stability, low acquisition costs and a robust solution for rough industrial usage.

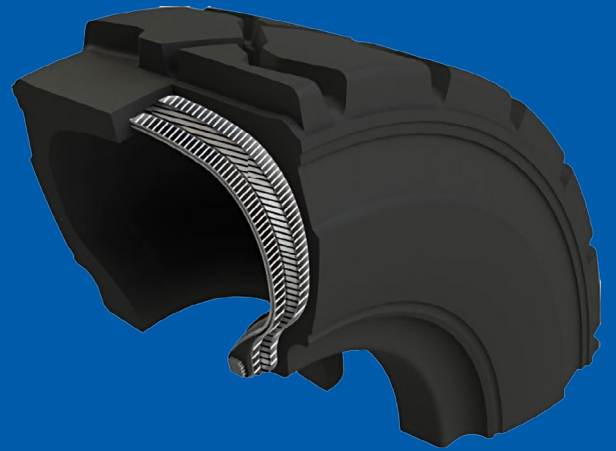

SOLIDEAL AIR 550

SUPERIOR DURABILITY,
PERFORMANCE AND COMFORT



[Click here to see
the complete line
overview](#)

Unique tread design with flat profile

- Increasing stability while reducing vibrations for better comfort



Deep tread lug with abrasion-resistant rubber compound

- Improves tire life and provides better traction

Thick sidewall

- Protects against side impacts causing flat tires

Heavy-duty carcass

- Maximizes tread puncture resistance to prevent flat tires

COMBINING A SMOOTH, COMFORTABLE RIDE WITH GREAT OVERALL TIRE LIFE. THANKS TO ITS UNIQUE TREAD DESIGN, SUPERIOR CARCASS STRENGTH AND SIDEWALL PROTECTION WHICH MAKES IT THE LOWEST OPERATING COST SOLUTION.

PERFORMANCE INDICATORS

May differ depending on the vehicle your tires are mounted on.

To see the full size list and performance ratings, [click here](#).



POPULAR SIZES

| | |
|--------------|--------------|
| 6.50-10/14PR | 28x9-15/14PR |
| 7.00-12/14PR | 5.00-8/10PR |
| 6.00-9/10PR | |

SOLIDEAL ED PLUS NM

DURABLE, PERFORMING AND
COMFORTABLE NON-MARKING TIRE



[Click here to see
the complete line
overview](#)

Deep tread lug

- Improves tire life and provides better traction

Unique tread design with flat profile

- Increases stability while reducing vibrations for better comfort



Thick sidewall

- Protects against side impacts causing flat tires
- Two times more rubber than standard tires

Heavy-duty carcass

- Maximizes tread puncture resistance to prevent flat tires

Non-marking natural rubber compound

- Prevents visible marks on the floor, ensuring a clean working environment
- Reduces chunking and cutting

PROVIDES SUPERIOR CARCASS STRENGTH AND SIDEWALL PROTECTION, IT'S ALSO THE IDEAL NON-MARKING SOLUTION FOR INDOOR OPERATIONS AND FOR ELECTRICAL AND RENTAL FLEETS.

PERFORMANCE INDICATORS

May differ depending on the vehicle your tires are mounted on.

To see the full size list and performance ratings, [click here](#).



POPULAR SIZES

| | |
|--------------|--------------|
| 6.50-10/14PR | 28x9-15/14PR |
| 7.00-12/14PR | 5.00-8/10PR |
| 6.00-9/10PR | |

SOLIDEAL AIR 570

ENERGY EFFICIENT SOLUTION
FOR ELECTRIC TRUCKS



[Click here to see
the complete line
overview](#)

Flat tread profile

- Enhances stability and provides even tire wear

RIB pattern and low-abrasion compound

- Provides low-rolling resistance for best energy efficiency



Reinforced carcass and sidewall

- Provides additional puncture resistance to prevent flat tires

Smooth continuous center lug

- Reduces vibration and provides enhanced steerability

OUR BEST ALL-AROUND PNEUMATIC TIRE FOR ELECTRIC FORKLIFTS. ENGINEERED TO DELIVER LOW ROLLING RESISTANCE AND REDUCED VIBRATIONS FOR OPTIMAL PERFORMANCE.

PERFORMANCE INDICATORS

May differ depending on the vehicle your tires are mounted on.

To see the full size list and performance ratings, [click here](#).



POPULAR SIZES

15x4 1/2-8/12PR

23x9-10/16PR

5.00-8/8PR

18x7-8/14PR

SOLIDEAL HAULER LT

READY FOR YOUR CHALLENGES



[Click here to see the complete line overview](#)

Wide square tread profile

- Provides superior stability

Massive tread blocks and deep lugs

- Extend service life in severe applications



Wide sidewall with rim guard

- Provides great side impact resistance
- Three times thicker than our standard tires

Reinforced undertread

- Increases puncture resistance

WITH A HEAVY-DUTY CARCASS AND HIGH ABRASION-RESISTANT TREAD, IT DELIVERS BOTH INCREDIBLE PUNCTURE RESISTANCE AND LONG LIFE. WITH A REINFORCED SIDEWALL FOR SIDE IMPACT PROTECTION, IT'S UNSTOPPABLE.

PERFORMANCE INDICATORS

May differ depending on the vehicle your tires are mounted on.

To see the full size list and performance ratings, [click here](#).



POPULAR SIZES

| | |
|---------|---------|
| 7.00-12 | 18x7-8 |
| 6.00-9 | 28x9-15 |
| 6.50-10 | |

SOLIDEAL HAULER SM

READY FOR YOUR CHALLENGES



[Click here to see
the complete line
overview](#)

Wide smooth profile

- Provides low vibrations (comfort) and prevents lug tearing on the steer axles on abrasive surfaces



Wide sidewall with rim guard

- Provides best side impact resistance
- Three times thicker than our standard tires

ITS SMOOTH TREAD PATTERN INCREASES TIRE LIFE PREVENTS LUG TEARING
AND INCREASES STEERABILITY.

PERFORMANCE INDICATORS

May differ depending on the vehicle your tires are mounted on.

To see the tires' performance ratings, [click here](#).



AVAILABLE SIZES

10.00-20

12.00-20

SOLIDEAL HAULER HA-TR

READY FOR YOUR CHALLENGES



[Click here to see
the complete line
overview](#)

Wide smooth profile

- Provides low vibrations (comfort) and prevents lug tearing on the steer axles on abrasive surfaces

Massive tread blocks and deep lugs

- Extend service life in severe applications



Wide sidewall with rim guard

- Provides best side impact resistance
- Three times thicker than our standard tires

ITS UNIQUE HALF-LUG, HALF-SMOOTH TREAD PATTERN PROVIDES EXCELLENT DURABILITY FOR ROAD-TO-RAIL APPLICATIONS, AS WELL AS PREVENTING TAPERED WEAR IN DUAL DRIVE SETUPS.

PERFORMANCE INDICATORS

May differ depending on the vehicle your tires are mounted on.

To see the tires' performance ratings, [click here](#).



AVAILABLE SIZES

10.00-20

12.00-20

SOLIDEAL PORTMASTER HD



NO STRONGER BIAS TIRE



[Click here to see the complete line overview](#)



Massively deep tread

- Provides longer service life on any surface

Strong carcass and sidewall protection

- Prevents carcass damages due to cutting and sidewall impact

OUR STRONGEST AND MOST DURABLE BIAS TIRE. IDEAL ON HARD SURFACES AND IN HIGHLY ABRASIVE ENVIRONMENTS, ITS EXTREMELY DEEP TREAD INCREASES SERVICE LIFE WHILE PROVIDING THE STRONGEST CARCASS AND THE MOST SIDEWALL PROTECTION POSSIBLE.

PERFORMANCE INDICATORS

May differ depending on the vehicle your tires are mounted on.

To see the tires' performance ratings, [click here](#).



AVAILABLE SIZES

12.00-20/20PR

12.00-20/28PR

SOLIDEAL AIR 561

PERFECT SOLUTION FOR GROUND
SUPPORT EQUIPMENT



[Click here to see
the complete line
overview](#)

Distinctive rib pattern design

- Reduces rolling resistance, vibrations and prevents snaking

Unique lugs with sipes design

- Increases traction on low grip conditions



Deep tread lugs with high performance compound

- Increases tire life

Energy-efficient rubber compound

- Help reduce wear on heated airport apron surfaces

ESPECIALLY DESIGNED FOR GROUND SUPPORT EQUIPMENT, THIS TIRE DELIVERS GREAT LIFE ON HIGH TEMPERATURE APRON SURFACES WHILE ENSURING LOW ROLLING RESISTANCE AND INCREASED TRACTION.

PERFORMANCE INDICATORS

May differ depending on the vehicle your tires are mounted on.

To see the tires' performance ratings, [click here](#).



AVAILABLE SIZES

6.00-9/10PR

7.00-12/14PR

8.00-16.5/10PR

SOLID **RESILIENT TIRES**

The construction of resilient tires includes several layers of different types of rubbers. Most resilient tires consist of a tread layer, a middle layer and a heel layer with steel bead reinforcements. Their key benefits include puncture and maintenance free operations, high mileage and low cost per hour.



RES INTENSITY LEVEL



SOLIDEAL RES 660 XTREME SERIES

OUR LONGEST LASTING TIRE
FOR HIGH INTENSITY APPLICATIONS



[Click here to see
the complete line
overview](#)



Continuous center lug

- Reduces vibration which lowers heat build-up and increases life
- Increases operator comfort and slows wear on driveline components

Exceptional tread rubber compound properties

- Makes this tire our longest lasting tire for high intensity applications



Wide tread profile

- Increases lateral load stability
- Safer in high-lift and cornering situations

Wear indicator

- Ensures maximum tire utilization

Cool running rubber compounds

- Withstand high intensity usage and offer low energy consumption

THE ULTIMATE TIRE FOR HIGH INTENSITY USE. THE SOLIDEAL RES 660 RUNS AT OVERALL LOWER OPERATING TEMPERATURES TO WITHSTAND NON-STOP USAGE AND HIGH LOAD ENVIRONMENTS.

A HIGH PERFORMING ABRASION RESISTANT TREAD RUBBER COMPOUND MAKES THIS TIRE OUR LONGEST LASTING TIRE FOR HIGH INTENSITY APPLICATIONS.

PERFORMANCE INDICATORS

May differ depending on the vehicle your tires are mounted on.

To see the full size list and performance ratings, [click here](#).



POPULAR SIZES

| | |
|---------|---------|
| 18x7-8 | 7.00-12 |
| 6.00-9 | 28x9-15 |
| 6.50-10 | |

SOLIDEAL RES XTREME NM

OPTIMAL NON-MARKING RESILIENT
SOLUTION FOR HIGH INTENSITY
APPLICATIONS



[Click here to see
the complete line
overview](#)



Wide tread profile

- Increases lateral load stability
- Safer in high-lift and cornering situations

Continuous center lug

- Reduces vibrations which lowers heat build-up and increases life
- Increases operator comfort and slows wear on driveline components



Wear indicator

- Ensures maximum utilization

Non-marking natural rubber compound

- Prevents visible marks on the floor, ensuring a clean working environment
- Reduces chunking and cutting

THE PREFERRED SOLUTION FOR HIGH INTENSITY APPLICATIONS REQUIRING
NON-MARKING RESILIENT TIRES. ITS DESIGN INCREASES STABILITY, REDUCES VIBRATION
AND IMPROVES OPERATOR COMFORT.

PERFORMANCE INDICATORS

May differ depending on the vehicle your tires are mounted on.

To see the full size list and performance ratings, [click here](#).



POPULAR SIZES

18x7-8

200/50-10

140/55-9

23x9-10

SOLIDEAL RES 550 MAGNUM SERIES

OUR LONGEST LASTING TIRE FOR
MEDIUM INTENSITY APPLICATIONS



[Click here to see
the complete line
overview](#)



Wide profile and flat footprint

- Increases stability and grip

Established tread pattern design

- Proven reliability for over 25 years



Exceptional tread rubber compound properties

- Makes this tire our longest lasting tire for medium intensity applications

Large tread blocks and deep lugs

- Maximizes life and traction

THE STANDARD IN RELIABILITY AND OUR LONGEST LASTING TIRE FOR MEDIUM INTENSITY APPLICATIONS. ITS WIDE PROFILE AND FLAT FOOTPRINT DESIGNED TO MAXIMIZE LIFE. ITS LARGE TREAD BLOCKS AND DEEP LUGS INCREASE TRACTION, WHILE DELIVERING MAXIMUM STABILITY.

PERFORMANCE INDICATORS

May differ depending on the vehicle your tires are mounted on.

To see the full size list and performance ratings, [click here](#).



POPULAR SIZES

| | |
|---------|---------|
| 18x7-8 | 7.00-12 |
| 6.00-9 | 28x9-15 |
| 6.50-10 | |

SOLIDEAL MAGNUM NM

MAGNUM SERIES

OPTIMAL NON-MARKING RESILIENT SOLUTION FOR MEDIUM INTENSITY APPLICATIONS



 [Click here to see the complete line overview](#)



Wide profile and flat footprint

- Increases stability and grip

Established tread pattern design

- Proven reliability for over 25 years

Non-marking natural rubber compound

- Prevents visible marks on the floor, ensuring a clean working environment
- Reduces chunking and cutting

Large tread blocks and deep lugs

- Maximizes life and traction



ITS CLEAN RUNNING AND VERSATILITY MAKES THIS TIRE THE IDEAL SOLUTION FOR INDOOR OPERATIONS AND FOR ELECTRICAL AND RENTAL FLEETS.

PERFORMANCE INDICATORS

May differ depending on the vehicle your tires are mounted on.

To see the full size list and performance ratings, [click here](#).



POPULAR SIZES

| | |
|---------|---------|
| 18x7-8 | 7.00-12 |
| 6.00-9 | 28x9-15 |
| 6.50-10 | |

SOLIDEAL RES 330

OUR LONGEST LASTING TIRE
FOR LOW INTENSITY APPLICATIONS



[Click here to see
the complete line
overview](#)



Well-balanced rubber compound

- Operates in low intensity applications and offers the lowest operating cost

Aggressive deep tread design

- Provides great traction and stability



Exceptional tread rubber compound properties

- Makes this tire our longest lasting tire for low intensity applications

Steel bead reinforced heel

- Prevents rim slip

Wear indicator

- Ensures maximum tire utilization

BEST-IN-CLASS TIRE FOR LOW-INTENSITY APPLICATIONS. A HIGH PERFORMING TREAD RUBBER COMPOUND MAKES THIS TIRE UNIQUE AND LONG LASTING; A WIDE, AGGRESSIVE TREAD WITH NATURAL RUBBER COMPOUNDS EXTENDS ITS LIFE WHILE RESISTING CUTTING AND CHUNKING.

PERFORMANCE INDICATORS

May differ depending on the vehicle your tires are mounted on.

To see the full size list and performance ratings, [click here](#).



POPULAR SIZES

18x7-8

6.00-9

6.50-10

SOLIDEAL RIB

ULTIMATE SOLID TIRE FOR BAGGAGE CARTS AND FORKLIFT APPLICATIONS



[Click here to see
the complete line
overview](#)

Circumferential ribs

- High cornering capability and low vibration
- Prevents snaking and cupping

Low rolling resistance

- Increases battery life and reduces fuel consumption



Excellent tread rubber compound

- Enhances tire performance and life

THE SOLIDEAL RIB TACKLES SPECIFIC AIRPORT GROUND SUPPORT EQUIPMENT CHALLENGES LIKE SNAKING AND CUPPING, AND OFFERS LOW VIBRATION AND OPTIMAL STEERING ON FORKLIFT TRUCKS. IT ALSO PROVIDES VERY LOW ROLLING RESISTANCE FOR BEST ENERGY EFFICIENCY AND ENHANCED TIRE LIFE.

PERFORMANCE INDICATORS

May differ depending on the vehicle your tires are mounted on.

To see the full size list and performance ratings, [click here](#).



POPULAR SIZES

4.00-8

140/55-9

200/50-10

SOLIDEAL SOLIDAIR LT

MOST COMFORTABLE
RESILIENT TIRE



[Click here to see
the complete line
overview](#)



Continuous center lug

- Reduces vibration which lowers heat build-up and increases life
- Increases operator comfort and slows wear on driveline components



Unique Solidair aperture design

- Improves ride quality
- Ensures great stability
- Reduces vibrations and prevents shock transfer

A SOLID TIRE WITH A UNIQUE APERTURE DESIGN PREVENTS SHOCK TRANSFER TO FRAGILE OR IMPACT-SENSITIVE LOADS. PROVIDES OPERATORS WITH A MORE COMFORTABLE RIDE ON UNEVEN SURFACES.

PERFORMANCE INDICATORS

May differ depending on the vehicle your tires are mounted on.

To see the full size list and performance ratings, [click here](#).



POPULAR SIZES

6.00-9

6.50-10

7.00-12

SOLIDEAL SOLIDAIR ZZRIB

PUNCTURE-FREE TIRE DESIGNED
SPECIFICALLY FOR BAGGAGE TRACTORS



[Click here to see
the complete line
overview](#)

ZZRib pattern for GSE application

- No vibrations
- Great cornering capabilities

Puncture proof

- No downtime due to tire damage/punctures
- Low maintenance (no pressure control)



Unique Solidair aperture design

- Improves ride quality
- Ensures great stability
- Reduces vibrations and prevents shock transfer

THE SOLIDAIR ZZRIB IS AN INNOVATIVE SOLID RESILIENT TIRE FOR BAGGAGE TRACTORS IN AIRPORTS. IT'S A COMPLETE PUNCTURE PROOF SOLUTION TO ENSURE NO DOWNTIME AND LOW MAINTENANCE. APERTURE HOLES IN THE TIRE SIDEWALL ARE OFFERING IMPROVED COMFORT AND SHOCK ABSORPTION.

PERFORMANCE INDICATORS

May differ depending on the vehicle your tires are mounted on.

To see the full size list and performance ratings, [click here](#).



POPULAR SIZES

6.00-9

6.50-10

7.00-12

7.00-15

SOLIDEAL HT BOMBER

SOLIDS ARE A TRUE VALUE
FOR THE MONEY



[Click here to see
the complete line
overview](#)

Special rubber compound

- Special rubber compound for low intensity applications



Quick heel fitment

- Eliminates the need for wheel components and makes it a cost-effective solution

Wide and deep lug pattern

- Ensures good traction and braking performance

THE HT BOMBER IS A TOUGH SOLID RESILIENT TIRE FOR LOW INTENSITY TRAILER APPLICATIONS.
IT CAN HANDLE THE HARSHTEST WORK CONDITIONS IN PORT TERMINALS.
A TIRE THAT OFFERS GREAT VALUE FOR MONEY.

PERFORMANCE INDICATORS

May differ depending on the vehicle your tires are mounted on.

To see the tires' performance ratings, [click here](#).



AVAILABLE SIZE

10.00-20/7.50

SOLIDEAL SM

PUNCTURE-FREE TIRE DESIGNED SPECIFICALLY FOR TRAILER AND FORKLIFT APPLICATIONS



[Click here to see the complete line overview](#)

Smooth slick tire tread

- Great cornering capabilities
- No vibration for increased driver comfort and low wear on the machine components

Low rolling resistance

- Increases battery life and reduces fuel consumption



Excellent tread rubber compound

- Enhances tire performance and life

ALL AROUND SOLID RESILIENT TIRE FOR BOTH TRAILER AND FORKLIFT APPLICATIONS WITH AN OUTSTANDING TIRE LIFETIME. THE SMOOTH TREAD OFFERS GREAT CORNERING CAPABILITIES AND A COMFORTABLE RIDE WITH NO VIBRATIONS. THE LOW ROLLING RESISTANCE REDUCES THE ENERGY USE OF THE MACHINE.

PERFORMANCE INDICATORS

May differ depending on the vehicle your tires are mounted on.

To see the full size list and performance ratings, [click here](#).



POPULAR SIZES

10.00-20

7.00-12

6.00-9

SOLIDEAL SMSL+

PUNCTURE-FREE TIRE DESIGNED
SPECIFICALLY FOR PORT TRAILERS



[Click here to see
the complete line
overview](#)

Smooth slick tire tread

- Great cornering capabilities
- Best braking power
- No vibrations



Low heat build-up rubber compound

- Specifically designed for very high intensive trailer applications
- Protects the tire from overheating
- Low rolling resistance: for less fuel consumption

SOLID RESILIENT TIRE WITH EXCEPTIONAL PERFORMANCE IN TERMS OF RESISTANCE TO HEAT BUILD-UP, WHICH IS KEY IN VERY HIGH INTENSITY TRAILER APPLICATIONS. THE SMOOTH TREAD IS PROVEN TO BE THE MOST RELIABLE SOLUTION FOR TRAILERS.

PERFORMANCE INDICATORS

May differ depending on the vehicle your tires are mounted on.

To see the tires' performance ratings, [click here](#).



AVAILABLE SIZE

10.00-20/7.5

QUICK HEEL TECHNOLOGY

A SIMPLER SOLUTION FOR SOLID RESILIENT TIRES

There are **two heel technologies available** for solid resilient tires:

STANDARD HEEL

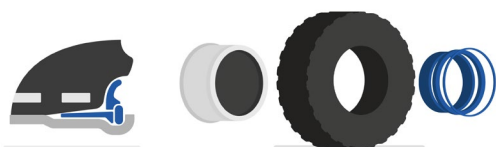

The standard heel needs multiple locking components on the rim to keep the tire in place: the advance band, the side ring and the lock ring.

QUICK HEEL



The quick heel technology is designed to perfectly match the rim contour, ensuring a full contact without the need for additional locking components.

SIMPLER. SAFER. BETTER.

Installation of multiple components requires additional steps during the tire demounting and mounting process, which means more time out of service for forklifts, in addition to potential safety issues when the locking components are not properly installed or damaged.

Quick heels have been designed to eliminate the need for the additional locking components. They offer a safer and simpler solution to maximize uptime of your fleets and eliminate safety risks.



[Click here to see video](#)

PROVEN SOLUTION FOR OVER 30 YEARS, APPROVED BY OEMS

Rely on a technology that has been widely used across Europe for over 30 years, has become a worldwide standard and offers a proven solution approved by major OEMs and other industry leaders.

For more information, visit [camso.co](https://www.camso.co)

SOLID **PRESS-ON TIRES**

Press-on tires, also known as cushion tires, are solid tires made of a rubber tread layer bonded to a cylindrical steel band. They are mounted onto a steel hub using a press. Their key benefits include a high load carrying capacity, great stability as well as puncture and maintenance free operations.

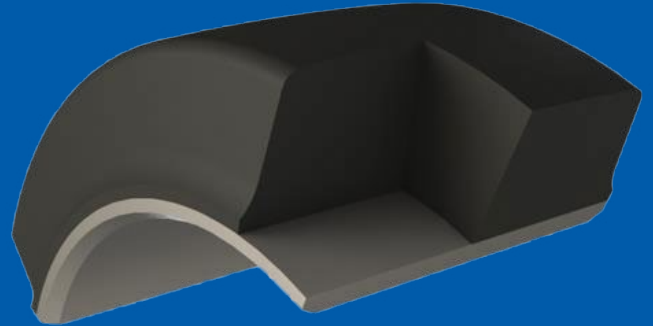

PON INTENSITY LEVEL



SOLIDEAL PON 775

DESIGNED FOR HIGH INTENSITY APPLICATIONS



[Click here to see the complete line overview](#)



Widest possible flat footprint

- Reduces ground pressure to minimize heat build-up

Thermally efficient construction

- Provides a cooler running tire and the best in class energy efficiency

Abrasion-resistant tread compound

- Increases tire life



Unique sidewall design

- Reduces heat build-up caused by stresses in the tread shoulders

Wear indicator and safety line

- Indicates when you should replace your tire

ENGINEERED TO PROVIDE THE BEST PERFORMANCE OF HEAT RESISTANCE, ENERGY EFFICIENCY AND LONG LASTING LIFE IN HIGH INTENSITY APPLICATIONS.

PERFORMANCE INDICATORS

May differ depending on the vehicle your tires are mounted on.

To see the full size list and performance ratings, [click here](#).



POPULAR SIZES

| | |
|-------------|-------------|
| 21x7x15 | 18x7x12 1/8 |
| 21x8x15 | 22x12x16 |
| 16x6x10 1/2 | |

SOLIDEAL PON 775 NMAS

ENGINEERED TO PREVENT STATIC SHOCKS
IN HIGH INTENSITY APPLICATIONS



[Click here to see the complete line overview](#)



Patented anti-static technology

- Prevents static electricity build-up to eliminate the risk of safety issues and truck damage

Thermally efficient construction

- Provides a cooler running tire and the best in class energy efficiency

Abrasion-resistant tread compound

- Increases tire life

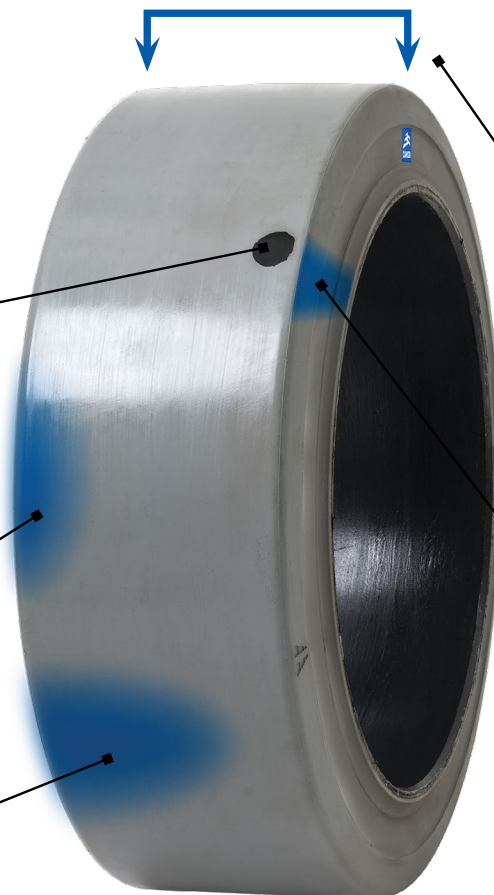

Widest possible flat footprint

- Reduces ground pressure to minimize heat built-up

Uniquely engineered sidewall

- Reduces heat build-up caused by stresses in the tread shoulders

ENGINEERED TO PREVENT STATIC SHOCKS AND PROVIDE THE BEST PERFORMANCE OF HEAT RESISTANCE, ENERGY EFFICIENCY AND LONG-LASTING LIFE IN HIGH INTENSITY APPLICATIONS.

PERFORMANCE INDICATORS

May differ depending on the vehicle your tires are mounted on.

To see the full size list and performance ratings, [click here](#).



POPULAR SIZES

| | |
|-------------|-------------|
| 21x7x15 | 18x7x12 1/8 |
| 21x8x15 | 22x12x16 |
| 16x6x10 1/2 | |

SOLIDEAL PON 555

DURABILITY YOU CAN RELY ON



[Click here to see the complete line overview](#)



Optimal crowned profile

- Excellent cushioning for improved comfort



High-performance natural rubber compound

- Reduces chunking and cutting
- Suitable for both IC and electric trucks

MADE WITH HIGH-PERFORMANCE, NATURAL RUBBER COMPOUNDS. RESISTS CHUNKING AND CUTTING IN THE MOST DEMANDING APPLICATIONS, WHILE DELIVERING MAXIMUM LIFE AND STABILITY FOR MEDIUM INTENSITY APPLICATIONS.

PERFORMANCE INDICATORS

May differ depending on the vehicle your tires are mounted on.

To see the full size list and performance ratings, [click here](#).



POPULAR SIZES

21x7x15

16x6x10 1/2

16x5x10 1/2

SOLIDEAL PON 555 NM

NON-MARKING WITH MAXIMUM LIFE
FOR MEDIUM INTENSITY APPLICATIONS



[Click here to see
the complete line
overview](#)



Low rolling resistance compound

- Increases energy efficiency and thermal performance

Non-marking natural rubber compound

- Prevents visible marks on the floor, ensuring a clean working environment
- Reduces chunking and cutting

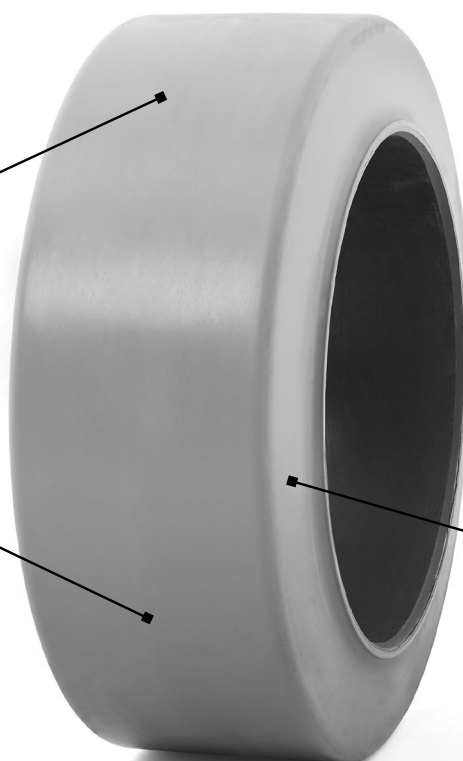

Unique two-stage construction

- Inner thermal-layer reduces heat build-up for enhanced tire life

ENHANCED NON-MARKING NATURAL RUBBER COMPOUND ENSURES CLEAN WORKING ENVIRONMENT, LOW ROLLING RESISTANCE AND IMPROVED THERMAL PERFORMANCE.

PERFORMANCE INDICATORS

May differ depending on the vehicle your tires are mounted on.

To see the full size list and performance ratings, [click here](#).



POPULAR SIZES

21x7x15

16x6x10 1/2

16x5x10 1/2

SOLIDEAL PON 550

DURABILITY YOU CAN RELY ON



[Click here to see the complete line overview](#)

Wide profile and flat footprint

- Increases stability and grip

High-performance natural rubber compound

- Reduces chunking and cutting
- Suitable for both IC and electric trucks



Huge lug depth

- Increases life and traction



RESISTS CHUNKING AND CUTTING IN THE MOST DEMANDING APPLICATIONS, WHILE DELIVERING MAXIMUM LIFE AND STABILITY FOR MEDIUM INTENSITY APPLICATIONS.

PERFORMANCE INDICATORS

May differ depending on the vehicle your tires are mounted on.

To see the full size list and performance ratings, [click here](#).



POPULAR SIZES

21x7x15

16x6x10 1/2

16x5x10 1/2

SOLIDEAL PON 550 NM

NON-MARKING WITH MAXIMUM
LIFE FOR MEDIUM INTENSITY
APPLICATIONS



[Click here to see
the complete line
overview](#)

Wide profile and flat footprint

- Increases stability and grip

Low rolling resistance compound

- Increases energy efficiency and thermal performance



Non-marking natural rubber compound

- Prevents visible marks on the floor, ensuring a clean working environment
- Reduces chunking and cutting

Unique two-stage construction

- Inner thermal-layer reduces heat build-up for enhanced tire life

ITS WIDE PROFILE, FLAT FOOTPRINT AND PROVEN TREAD PATTERN DESIGN PROVIDE MAXIMUM STABILITY AND TRACTION. ESPECIALLY DESIGNED TO PROVIDE MAXIMUM LIFESPAN FOR MEDIUM INTENSITY APPLICATIONS REQUIRING NON-MARKING PRESS-ON TIRES.

PERFORMANCE INDICATORS

May differ depending on the vehicle your tires are mounted on.

To see the full size list and performance ratings, [click here](#).



POPULAR SIZES

21x7x15

16x6x10 1/2

16x5x10 1/2

SOLIDEAL SM HL

DURABILITY YOU CAN RELY ON



[Click here to see the complete line overview](#)

Optimal crowned profile

- Excellent cushioning for improved steering



High-performance natural rubber compound

- Reduces chunking and cutting
- Designed to handle very high loads

MADE WITH HIGH-PERFORMANCE NATURAL RUBBER COMPOUNDS. RESISTS CHUNKING AND CUTTING IN THE MOST DEMANDING APPLICATIONS, WHILE DELIVERING MAXIMUM LIFE, SATBILITY AND HIGH LOAD CAPACITY.

PERFORMANCE INDICATORS

May differ depending on the vehicle your tires are mounted on.

To see the full size list and performance ratings, [click here](#).



POPULAR SIZES

40x16x30

28x12x22

28x14x22

SOLIDEAL SM SRP/SRP+

PERFORMANCE WHEN YOU NEED IT



[Click here to see the complete line overview](#)

Natural rubber compound

- Provides good overall wear and performance



Low rolling resistance solution

- For high intensity trailer applications

PRESS-ON TIRE DESIGNED TO DELIVER MAXIMUM LIFE AND VERY HIGH LOAD CARRYING CAPACITY. WITH ITS NATURAL RUBBER COMPOUNDS IT DELIVERS MAXIMUM LIFE WHERE PREMIUM TECHNOLOGY IS NOT REQUIRED.

PERFORMANCE INDICATORS

May differ depending on the vehicle your tires are mounted on.

To see the full size list and performance ratings, [click here](#).



POPULAR SIZES

22x16x16

425/150-305

405/130-305

645/250-410

INDUSTRIAL **WHEELS**

Our industrial wheels and wheel assemblies have been engineered for the world's leading OEMs, while working closely with major industry leaders to ensure that their design and manufacture meet all applicable standards. A combination of high-volume production plants with local specialized production facilities throughout the world allow us to provide high quality wheels and wheel assemblies in any volume.



INDUSTRIAL WHEELS

INDUSTRIAL WHEELS FOR YOUR
MATERIAL HANDLING APPLICATIONS



MULTI-PIECE WHEELS



SPLIT WHEELS

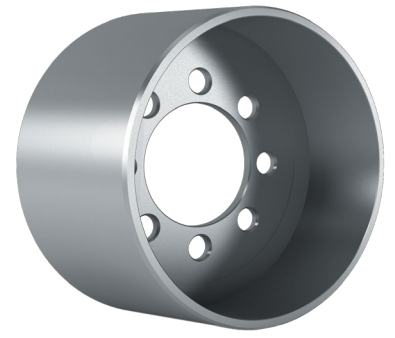

PRESS-ON WHEELS

GLOBALLY ESTABLISHED NETWORK OF ENGINEERING AND PRODUCTION FACILITIES WHICH PROVIDE ALSO SHORT-TERM DELIVERIES, FOCUSED ON YOUR SPECIAL DEMANDS, DUE TO WHEEL OPERATIONS IN USA, GERMANY, BELGIUM, AUSTRALIA AND SRI LANKA.

KNOXVILLE

DUISBURG

HERENTHOUT

EKALA

GIRRAWEEEN

For more information, please visit our [Industrial wheels section](https://www.camso.co) on [camso.co](https://www.camso.co)

ACCESSORIES

FOR RADIAL TIRES

EXAMPLE OF MARKING: 110 TL 8 (for 4.33R - 8 rim)

- 110** → Width of TBS in mm
- TL** → Tubeless
- 8** → Rim diameter in inch

The choice of TBS depends on the width of the rim on which the tire is to be fitted. The allowed rim width(s) are indicated on each TBS.

3 different valves exist for TBS when only R2160 an R2102 are provided as standard with the TBS.

TBS wider than 145 mm offer two positions for the valve to accommodate the rim configuration ; for those TBS, a specific plug (R2110) is provided to close the unused valve hole.

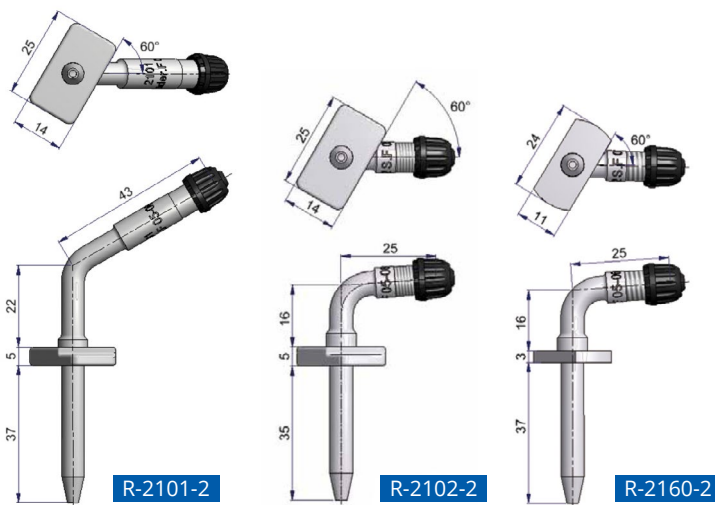

Valve holes

R-2110 Plastic obturator

TUBETYPE SYSTEM

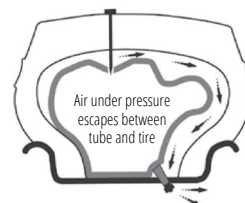

- Rapid deflations
- Risk for load or equipment damages
- Instant production stops

TUBELESS BEAD SEAL™

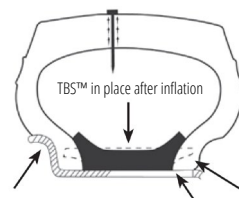

- Slower air loss delays need for immediate attention
- Equipment is still mobile and productive

CROSS SECTION OF A FITTED TBS

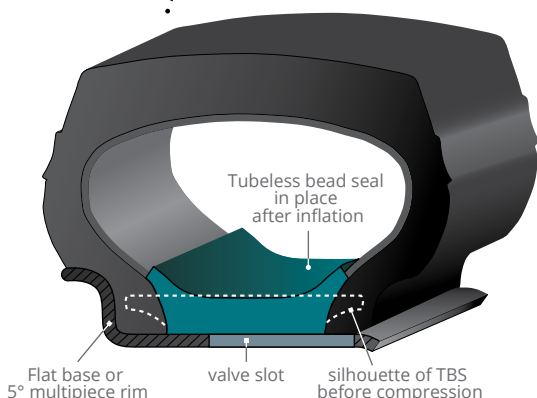

Ready to get you rolling

Our Solideal on-site services managed by an extensive network of dedicated Beyond Road technicians using specialized equipment will keep your operations rolling no matter what type of forklift tires you may need:



ON-SITE MOBILE UNIT

Supply & Fit Full Forklift Tire Service

Forklift tire mobile fitting, our core service, with best-in-class performance tires specifically selected to fit your customized fleet at the guaranteed lowest operating cost.

Service level is personalized according to your fleet analysis and business needs.

Professional Fleet Analysis Maintenance Cycle Optimization

Superior fleet solution for maximum uptime. In-depth fleet analyses that take into account your individual operating conditions.

Pneumatic tires Flat proofing program

Specialized solution for harsh applications. Professional polyurethane tire-filling with advanced filling technology “pure plus recycling” to ensure maximum tire lifetime in a sustainable way. Precise pressure calculation based on individual requirement.

Fit or Press Only Specific Forklift Tire Service

If you would like to order your tires yourself and prefer to have someone else look after the installation our order-based professional on-site service is designed to maximize your company’s uptime.

Beside fit or press services we may include a fleet analysis and tire recommendation to identify the lowest operating cost solution.

Tire Regrooving Life Extension Service

Maximize the life of your tire with constant tire performance by regrooved tread patterns & puncture repairs

Delivery Assembly mounting

Widest range of full assemblies (tire + wheel) available, ready to be delivered for your personal fleet needs.

Contactless service

One less thing to worry about with our contactless service: simply make your order via email or phone call.

Just tell us when you would like our mobile service to come to you, ensure that you have your forklift ready at the agreed time, and we'll take care of the complete tire service including real time communication.

No further on-site support is required. The digital order processing rounds off our contactless and efficient process.



Specialized technicians with in-depth knowledge of the most efficient replacement methods

Global partners network

Wherever you may be, you can also rely on our proven network of partners to assist you with your tire maintenance requirements.

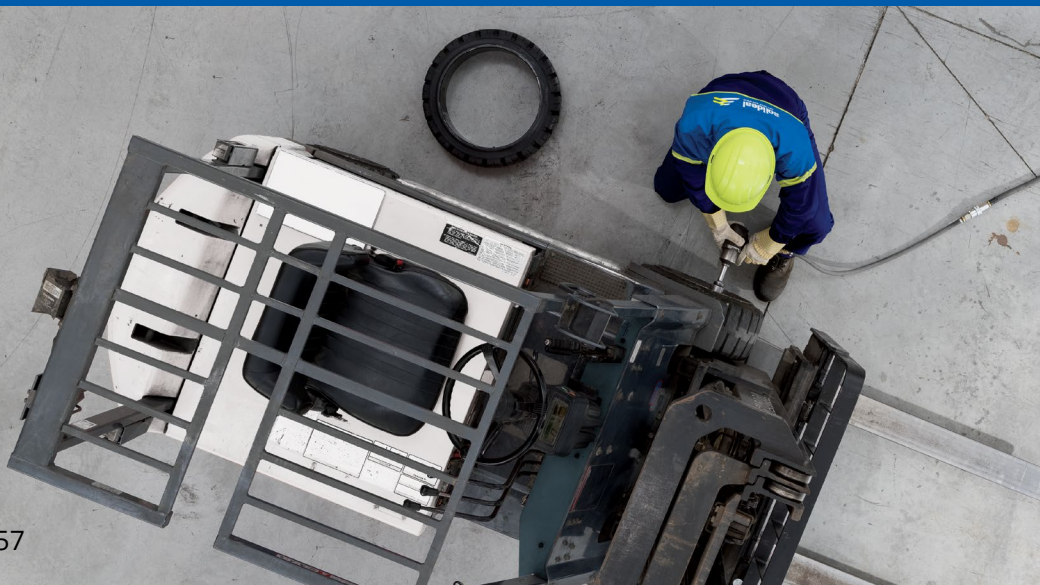

solideal
on-site service 

solideal.com



MAINTENANCE TIPS

FROM OUR EXPERTS

Our experts love to share tips to help our clients carry out safe and efficient operations, with maximized uptime. Here's a glimpse of some of our most relevant contents, which are available online.

WHEN TO REPLACE YOUR TIRES

RESILIENT TIRES

Should not be used beyond the 60J line (or safety line), as indicated on the sidewall.



PRESS-ON TIRES

Should be replaced when the overall rubber height reaches 2/3 of the original rubber height. Newer press-on tires have a safety line.

RADIAL & BIAS

INDUSTRIAL PNEUMATIC TIRES

Should be measured using a tread depth gauge in the middle of the tread to measure tread depth. Replace tires when the depth gets close to 0 millimeters.



THE IMPACT OF TIRE WEAR

The top 7 issues linked to tires are:

- Fatigue and job stress on the operator
- Sudden pressure loss
- Stability issues with loads
- Damage to the facility
- Leaking of engine and transmission due to loosened hardware
- Acceleration of fork heel wear
- Compromised loads



[Training Video Series](#)

MAINTENANCE TIPS

Here are our maintenance tips before getting back to work:

Check brakes

Inspect your tires

Look for damage and wear

Leakage

Check lines and hoses for leaks

Torquing

Ensure wheels are torqued correctly



Controls function

Make sure all forklift controls are functioning properly

Wear

Inspect fork for damage and heel wear

Inflation pressure

Check inflation pressure for pneumatics

HOW TO READ TIRE SIZE

RESILIENT AND INDUSTRIAL PNEUMATIC TIRES

Today, we find three different types of size markings for pneumatics and resilient tires. This is due to the evolution of the nomenclature over time. Radial tires include a **R** in their tire size.

PRESS-ON TIRES

Did you notice there were two different ways of displaying size marking on tires: imperial (inches) and metric (mm)? The size of a press-on tire is indicated in 3 numbers:

- 1 Overall diameter
- 2 Section width
- 3 Internal diameter

[How to read tire size: PON](#)

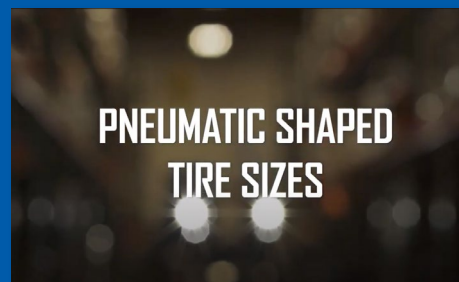

[How to read tire size: IND & RES](#)

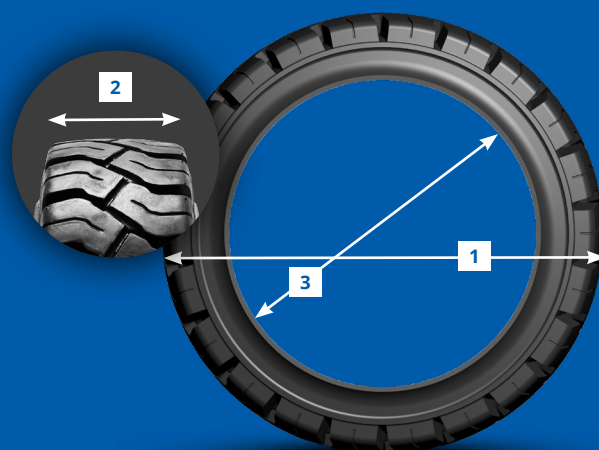

TOTAL COST OF OWNERSHIP OF YOUR TIRES

When it comes to tire costs, it's important to take more than the upfront cost of purchasing units: remember to take into consideration operational cost, tire performance and the requirements of the application.

Tires with lowest acquisition costs could end up costing more in the end, especially if they are not right for the application and take a toll on your machines. Our broad offering meets the specific requirements of any application, with a portfolio that offers both low acquisition and low operation cost solutions.

For additional support, our teams of dedicated specialists will be able to help you make the calculations.

POTENTIAL REPLACEMENT COSTS

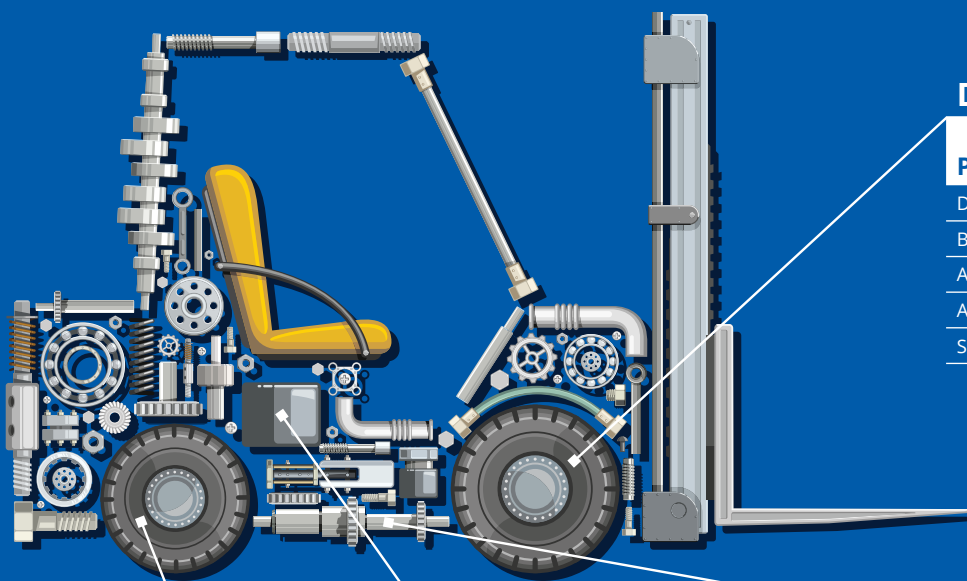

DRIVE AXLE

| PART | COST | LABOR HOURS |
|--------------------|-------------|-------------|
| Drive Axle Shaft | \$246 | 1 |
| Bearings | \$550 (set) | 2 |
| Axle Housing Mount | \$600 (ea.) | 4 |
| Axle Hub | \$610 (ea.) | 3 |
| SCR Components | \$500 | 4 |

STEER AXLE

| PART | COST | LABOR HOURS |
|----------------|---------------|-------------|
| Steer Axle | \$1,185 | 6 (IS) |
| King Pins | \$1,175 | 2-3 each |
| Bushings | \$1,160 | 2 (IS) |
| Bushings | \$1,210 (set) | 4 (IS) |
| Wheel Bearings | \$1,160 | 8 |
| Tie Rod Ends | \$1,115 (ea.) | 2 |
| Steer Cylinder | \$1,710 | 4 |
| Steer Knuckle | \$1,340 (ea.) | 2-3 each |

BATTERY

| PART | COST | LABOR HOURS |
|-------------------|---------|-------------|
| 36 Volt - 18 Cell | \$3,000 | |
| 48 Volt - 24 Cell | \$3,500 | |
| 1 Cell | \$3,200 | 2 |
| 1 Tray | \$3,350 | 15 |

DRIVE MOTOR

| PART | COST | LABOR HOURS |
|-----------------|---------------|-------------|
| Drive Motor | \$3,450 | 8 (IS) |
| Armature | \$1,775 | 8 (IS) |
| Brushes | \$1,752 (set) | 2 |
| Holder | \$1385 (set) | 4 |
| Fields | 1,800 (set) | 8 (IS) |
| Contractor Tips | \$1,105 | .3 |
| Pump Motor | \$1,800 | 2 |

*Prices are in USD.

STORAGE TIPS INDOOR VS. OUTDOOR HAVE DIFFERENT RULES

While indoor storage is preferable, tires can also be stored outside if they respect certain conditions. Moisture, high or variations in temperature and light all contribute to a faster aging of rubber. For tires stored outside, we recommend a maximum storage period of 4 months on a clean and well-drained surface.



[Maintenance and Use Guide](#)

WARRANTY

5 YEAR TIRE WARRANTY†

All products are guaranteed to be free from defects due to materials and workmanship.

If a product is deemed defective upon our examination and analysis inside a period of five (5) years from the day of manufacture of the product, we will provide an allowance against the current purchase price. The allowance will be determined, to be applied towards the purchase of a new product, based on the remaining unused portion of the tread or warrantable lifetime on the defective product.

For radial tires, five (5) years from the day of purchase will be taken into consideration by presenting the necessary requirements to prove the date of purchase. If no proof is submitted, we will take into account the five (5) years from the day of manufacture.

The cost of transportation, service, and sales tax already paid will be borne by the owner of the product making the claim. Warranty will not apply if the product has been installed incorrectly, altered, repaired or misused in any matter whatsoever, which, in our opinion, has affected the performance of the tire.

We can not be held responsible for damages or claims caused by the tire whether such damages are direct or indirect, special, consequential or otherwise. Any liability is strictly limited to repair or reduction of an applicable purchase, according to the mentioned provision in our General Claim Policy and Adjustments.

This warranty is for the exclusive benefit of the owner and is transferable to a subsequent owner but is not otherwise assignable

† This text is an extract of our General Claim Policy and Adjustments, which is the only valid and applicable Policy.

For the complete warranty details please visit connectbeyondroad.michelingroup.com or camso.co

WE HANDLE IT

LOCAL CONTACT INFORMATION



business.michelinman.com
business.michelin.co.uk



camso.co