



REGIONAL APPLICATIONS

THE MICHELIN X[®] MULTI D+ TIRE

The next generation regional drive tire offering more than 5% lower rolling resistance vs. its predecessor⁽¹⁾ with no compromises to traction or wear.⁽²⁾

Line Haul	Regional	Urban ⁽³⁾	On/Off Road
<input checked="" type="checkbox"/> Recommended	<input checked="" type="checkbox"/> Recommended	<input type="checkbox"/> Acceptable	<input type="checkbox"/> Acceptable



**MAXIMIZED
TREAD LIFE**

**EXCELLENT
TRACTION⁽¹⁾**

**CASING
DURABILITY**



(1) Based on internal ISO28580 testing vs Michelin X[®] Multi D
 (2) Next-generation traction and mileage. Guaranteed. See your Michelin Representative, Authorized Michelin Dealer, or visit business.michelinman.com for details.
 (3) Urban would include fleets that operate in an Urban construction environment that operate off road a maximum of 10%.



THE MICHELIN X[®] MULTI D+ TIRE

MAXIMIZED TREAD LIFE

Co-Extruded Compounding Scrub Resistant Rubber

- Ensures high mileage in the most demanding applications
- Reduced rolling resistance for improved fuel economy

Long Even Wear

- Incorporates Matrix siping and a bridged open shoulder.

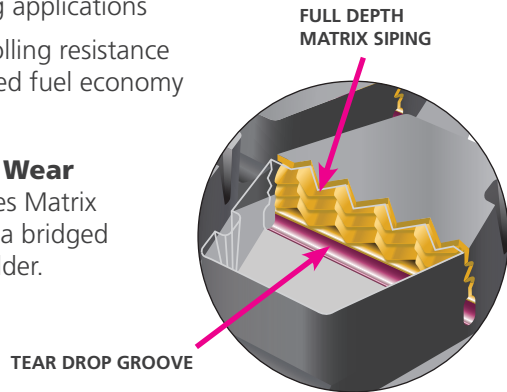

CASING DURABILITY

Cooler Running Rubber

- Minimizes heat build up leading to increased casing life.



TW6 OzoneShield –

- Double treatment of the sidewall for increased protection and lasting professional look

Full Width Protector Ply

- Protects the tire from nail penetrations and road hazards from shoulder to shoulder.



EXCELLENT TRACTION

More Grip, Less Slip

Full Depth Matrix Siping

- The sipe goes all the way to a tear drop groove, meaning no loss of the biting grip as the tire wears.

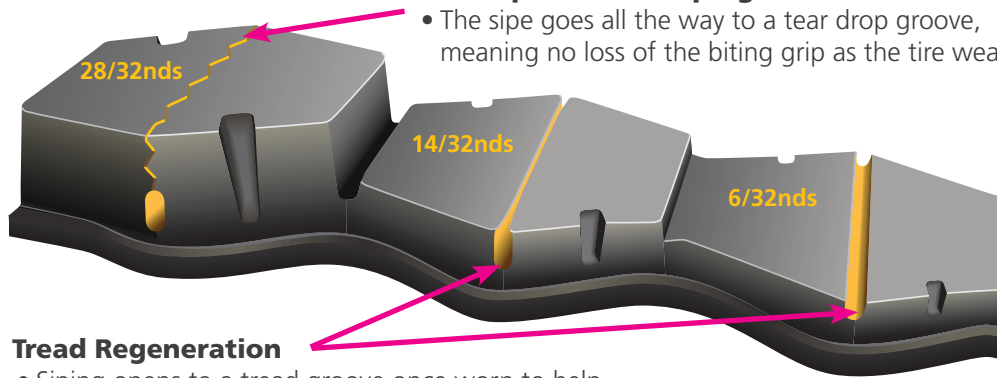

Tread Regeneration

- Siping opens to a tread groove once worn to help with additional water evacuation and traction

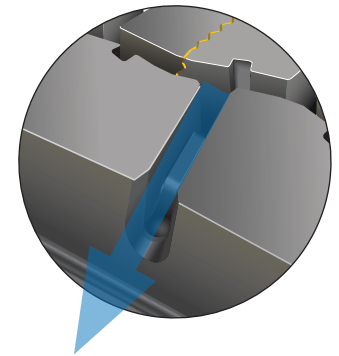

Pass Thru Open Shoulder

- Allows quick evacuation of material from beneath the tread surface area.

Line Haul	Regional	Urban ⁽¹⁾	On/Off Road
Recommended	Recommended	Acceptable	Acceptable

Size	Load Range	Catalog Number	Tread Depth		Max. Speed (+)	Loaded Radius		Overall Diameter		Overall Width (‡)		Approved Wheels (Measuring wheel listed first.)	Min. Dual Spacing (‡)		Revs Per Mile	Max. Load and Pressure Single				Max. Load and Pressure Dual			
			32nds	mm		in.	mm	in.	mm	in.	mm		in.	mm		lbs.	psi	kg.	kPa	lbs.	psi	kg.	kPa
11R22.5 ⁽²⁾	H	95809	28	75	120	19.6	498	41.9	1064	11.3	288	8.25, 7.50	12.5	318	494	6610	120	3000	830	6005	120	2725	830
275/80R22.5 ⁽²⁾	G	84661	27	75	120	19.0	483	40.5	1029	11.0	280	8.25, 7.50	12.2	311	510	6175	110	2800	760	5675	110	2575	760
11R24.5 ⁽²⁾	H	32561	28	75	120	20.5	521	43.8	1112	11.2	284	8.25, 7.50	12.5	318	472	7160	120	3250	830	6610	120	3000	830

Note: Wheel listed first is the measuring wheel.

(1) Urban would include fleets that operate in an Urban construction environment that operate off road a maximum of 10%.

(2) Next-generation traction and mileage. Guaranteed. See your Michelin Representative, Authorized Michelin Dealer, or visit business.michelinman.com for details.

(*) Exceeding the lawful speed limit is neither recommended nor endorsed.

(‡) Overall width will change 0.1 inch (2.5 mm) for each 1/4 inch change in wheel width. Minimum dual spacing should be adjusted accordingly.

MICHELIN[®] tires and tubes are subject to a continuous development program. Michelin North America, Inc. reserves the right to change product specifications at any time without notice or obligations.

MNA, Inc. continually updates its product information to reflect any changes in Industry Standards. Printed material may not reflect the current Load and Inflation information. Please visit www.michelintruck.com for the latest product information. The actual load and inflation pressure used must not exceed the wheel manufacturer's maximum conditions. Never exceed a wheel manufacturer's limits without permission from the component manufacturer.

TO FIND OUT MORE
US: business.michelinman.com
CA: business.michelin.ca

FIND US ON FACEBOOK
[michelintruck](https://www.facebook.com/michelintruck)

CONTACT US ON THE WEB
US: business.michelinman.com/contact-us
CA: business.michelin.ca/contact-us

CONTACT US BY TELEPHONE
US: 1-888-622-2306
CA: 1-888-622-2306