

*WHY CHOOSE
MICHELIN?*

*TYRE
BASICS*

*CHOOSING THE RIGHT
MICHELIN TYRE*

*MICHELIN TYRES FOR
E2A MARKETS*

*TECHNICAL
CHARACTERISTICS*

*TYRE KNOWLEDGE
AND SAFETY*

*VEHICLES AND
TYRE DIAGNOSTICS*

*REGROOVING /
RETREADING*

MICHELIN TECHNICAL DATA BOOK TRUCK AND BUS TYRES



FOR EAST ASIA AND AUSTRALIA

***2021** EDITION*

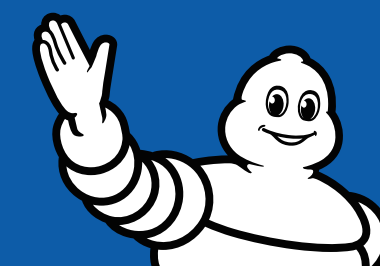

MICHELIN

PURPOSE OF THIS MANUAL

The purpose of this manual is to provide useful information to help obtain maximum performance at minimum cost per kilometre. This manual will assist fleets to increase their tyre knowledge and covers the full life cycle of the tyres: selection, vehicle characteristics that affect tyre performance, maintenance and tyre life extension through regrooving and retreading.

MICHELIN tyres are designed for a specific use as detailed in this catalogue. Any other use constitutes abnormal usage. However, in some cases, Michelin may waive the specific use conditions and limits and allow for a derogation. Michelin disclaims any liability for any abnormal use of our tyres in the absence of any specific written permission.

MICHELIN products are manufactured from high quality materials to high tolerances, ensuring a uniform and consistent performance. Correct application, fitting, inflation and regular inspection of the product is essential to safe and efficient operation.

MICHELIN Recamic and the tyre designations mentioned are trademarks of Michelin.

This manual gives Michelin recommendations for optimum use of tyres, nevertheless, Please refer to the regulation of each country for local operation.

For further information about any of the products in this document, contact your local Michelin representative.



SAFETY WARNINGS

BE SURE TO READ THE SAFETY INFORMATION PROVIDED HEREIN AS SERIOUS INJURY OR DEATH CAN RESULT FROM FAILURE TO FOLLOW SAFETY WARNINGS

- Tyre and rim servicing can be dangerous and must be done only by trained personnel using proper tools and procedures. Failure to read and comply with all procedures may result in serious injury or death to you or others.
- Re inflation of any type of tyre and rim assembly that has been operated in a run-flat or underinflated condition (80% or less of recommended operating pressure) can result in serious injury or death. The tyre may be damaged on the inside and can explode while you are adding air. The rim parts may be worn, damaged or dislodged and can explosively separate.
- Use of gasoline, petrol or any other flammable material to lubricate, seal or seat the beads of a tyre can cause the tyre to explode or can cause the explosive separation of the tyre/rim assembly resulting in serious injury or death. The use of any flammable material during tyre servicing is absolutely prohibited.
- Any inflated tyre mounted on a rim contains explosive energy. The use of damaged, mismatched or improperly assembled tyre/rim parts can cause the assembly to burst apart with explosive force. If you are struck by an exploding tyre, rim part or the air blast, you can be seriously injured or killed.
- Re-assembly and inflation of mismatched rim parts can result in serious injury or death. Just because parts fit together does not mean they belong together. Check for proper matching of all rim parts before putting any parts together.
- Mismatching tyre and rim diameters is dangerous. A mismatched tyre and rim assembly may explode and can result in serious injury or death. This warning applies to any combination of mismatched components. Never assemble a tyre and rim unless you have positively identified and correctly matched the parts.
- MICHELIN truck tyres are designed and optimized for specific conditions of usage which can be found in the MICHELIN Truck and Bus Tyre Technical Data Book and MICHELIN Truck and Bus Tyre Service Manual. It is therefore not advisable to use the product in conditions of use outside the parameters for which it was designed for. Operations outside these parameters are identified as abnormal usage and are not eligible for warranty consideration. Serious or fatal injury may result from tyre failure as a result of operating outside the tyres intended conditions of use. Refer to the MICHELIN Truck and Bus Tyre Technical Data Book (Asia Edition), MICHELIN Truck and Bus Tyre Service Manual, or consult your MICHELIN Truck Tyre professionals for recommendations and procedures.

GLOBAL AWARDS AND RECOGNITIONS

MICHELIN BRAND IS RECOGNIZED WORLDWIDE FOR ITS QUALITY AND SUPERIORITY.

NO.1 TYRE BRAND in several countries

Source: Reputation Institute World - 2017 Global RepTrak® 100 (02/2017)



TOP 10 : A RECOGNIZED ENVIRONMENTAL AND SOCIAL COMMITMENT

MICHELIN was awarded 9th place worldwide for our corporate responsibility by the CR Reprack 2018 to reward our social and environmental actions, our ethical way of doing business, and our satisfying work conditions and opportunities.



TOP 100

MICHELIN ranked 13th most reputable company in the world for the 3rd consecutive year

Source: Reputation Institute World - 2017 Global RepTrak® 100 (02/2017)

US\$7.232 BILLION

Brand value estimate in 2019

Source: Brand Finance Global 500

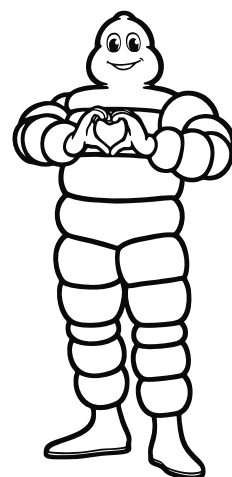

MICHELIN MAN

• Voted best icon in the world

Source: Financial times and R.O.B

• Icon of the Millenium

Source: Advertising Week New York 2018



APPRECIATED AND RECOGNIZED EMPLOYER



NO.1 employer in the US

Source: Forbes & Statista, Annual ranking of America's best employers 2017

INNOVATION & HIGH QUALITY TYRES

MICHELIN Evobib tyre: Gold Award by the SIMA Innovation Awards 2017

MICHELIN Vision concept tyre: "Best of the Best" award by Design Concept Red Dot 2018



GLOBAL AWARDS RECOGNITIONS

MICHELIN GLOBAL TECHNOLOGY CENTRE

MICHELIN MILESTONES

GLOBAL FOOTPRINT

MICHELIN TYRE TECHNOLOGIES

GLOBAL TECHNOLOGY CENTRE

IN CHARGE OF RESEARCH, DEVELOPMENT AND PROCESS ENGINEERING, WITH OPERATIONS IN EUROPE, NORTH AMERICA AND ASIA

1 GLOBAL TECH CENTRE
on 3 Continents

- North America
- Europe
- Asia/Oceania

350 Different Fields of Expertise within R&D

250 research partners

€700M
on R&D every year

6,000
Researchers and Technicians

11,700
Invention Patents

40,000
Vehicle Check-ups every year worldwide

GLOBAL AWARDS RECOGNITIONS

MICHELIN GLOBAL TECHNOLOGY CENTRE

MICHELIN MILESTONES

GLOBAL FOOTPRINT

MICHELIN TYRE TECHNOLOGIES

Source: Michelin Documents

MICHELIN MILESTONES

MORE INNOVATIVE, CLOSER TO CUSTOMERS

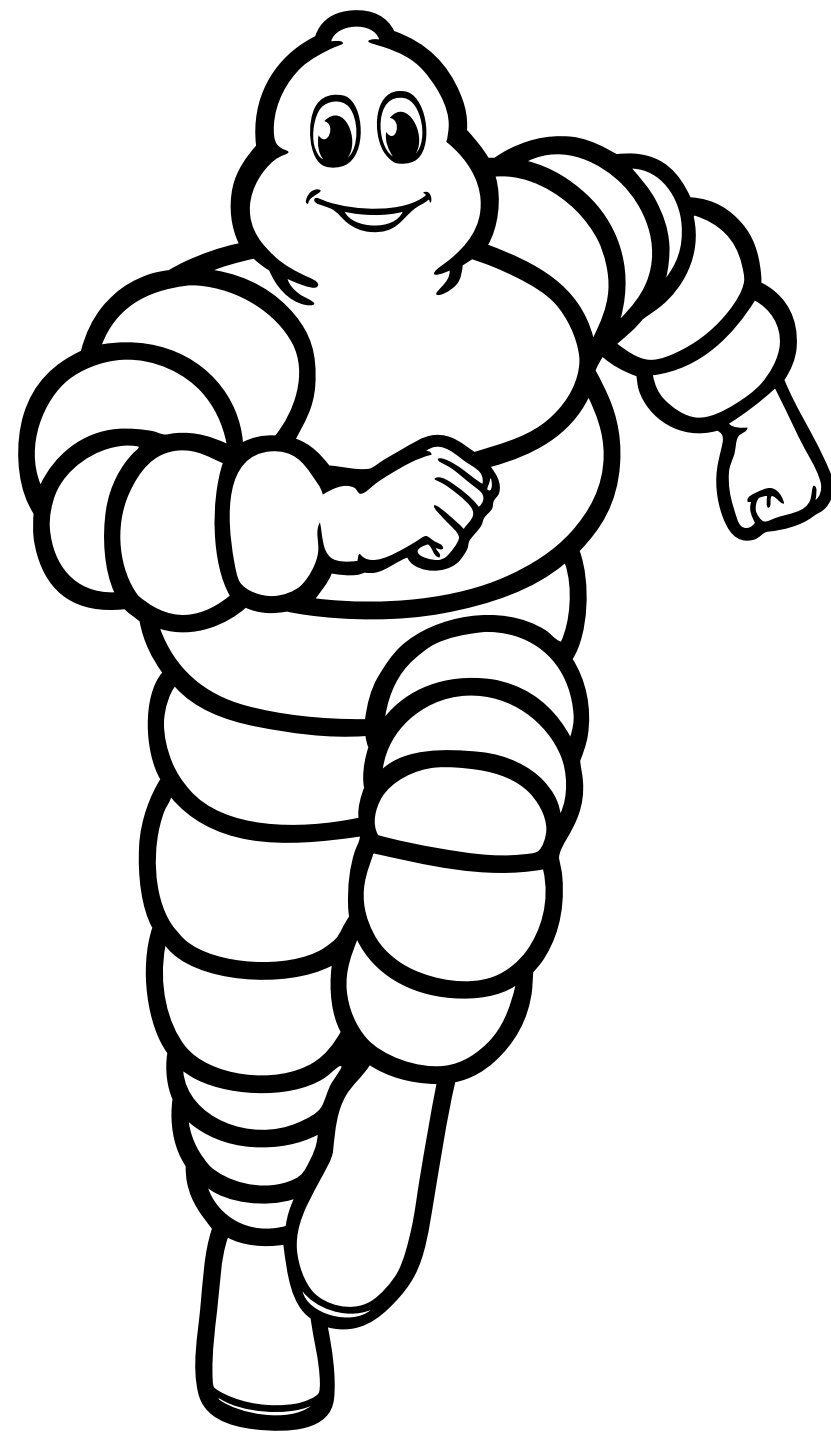

- **1891** Michelin developed the first detachable bicycle tyre.
- **1895** First car fitted with pneumatic tyres
- **1898** Birth of Bibendum, the "MICHELIN Man"
- **1900** First MICHELIN Guide published
- **1938** Truck tyre with steel casing
- **1946** Michelin filed a patent for the revolutionary "Radial" tyre
- **1952** Michelin Radial technology adapted in truck tyres
- **1981** Michelin developed the Michelin X Air, the first Radial aircraft tyre
- **1995** Space shuttle lands on MICHELIN tyres
- **2000** X-One Wide-Single truck tyre
- **2001** Michelin developed the MICHELIN XDR, the world's biggest earthmover tyre
- **2017** The MICHELIN VISION concept tyre
- **2017** PresSense, world's 1st connected tyre for aircraft (Joint Venture with Safran)
- **2018** The Michelin Man was named the Icon of the Millennium during Advertising Week in New York.
- **2018** Michelin acquired Camso, making the Group the world leader in off-the-road tyres. (+ Fenner)
- **2019** Michelin UPTIS, the airless tyre, was unveiled at the "Movin' On 2019" summit.
Michelin UPTIS represents a major innovation both in terms of safety and respect for the environment.
- **2019** Launch of MICHELIN X Multi Z 2
- **2020** MICHELIN Agilis 3 launched virtually in Southeast Asia

Source: Michelin website

GLOBAL AWARDS RECOGNITIONS

MICHELIN GLOBAL TECHNOLOGY CENTRE

MICHELIN MILESTONES

GLOBAL FOOTPRINT

MICHELIN TYRE TECHNOLOGIES

A GLOBAL FOOTPRINT

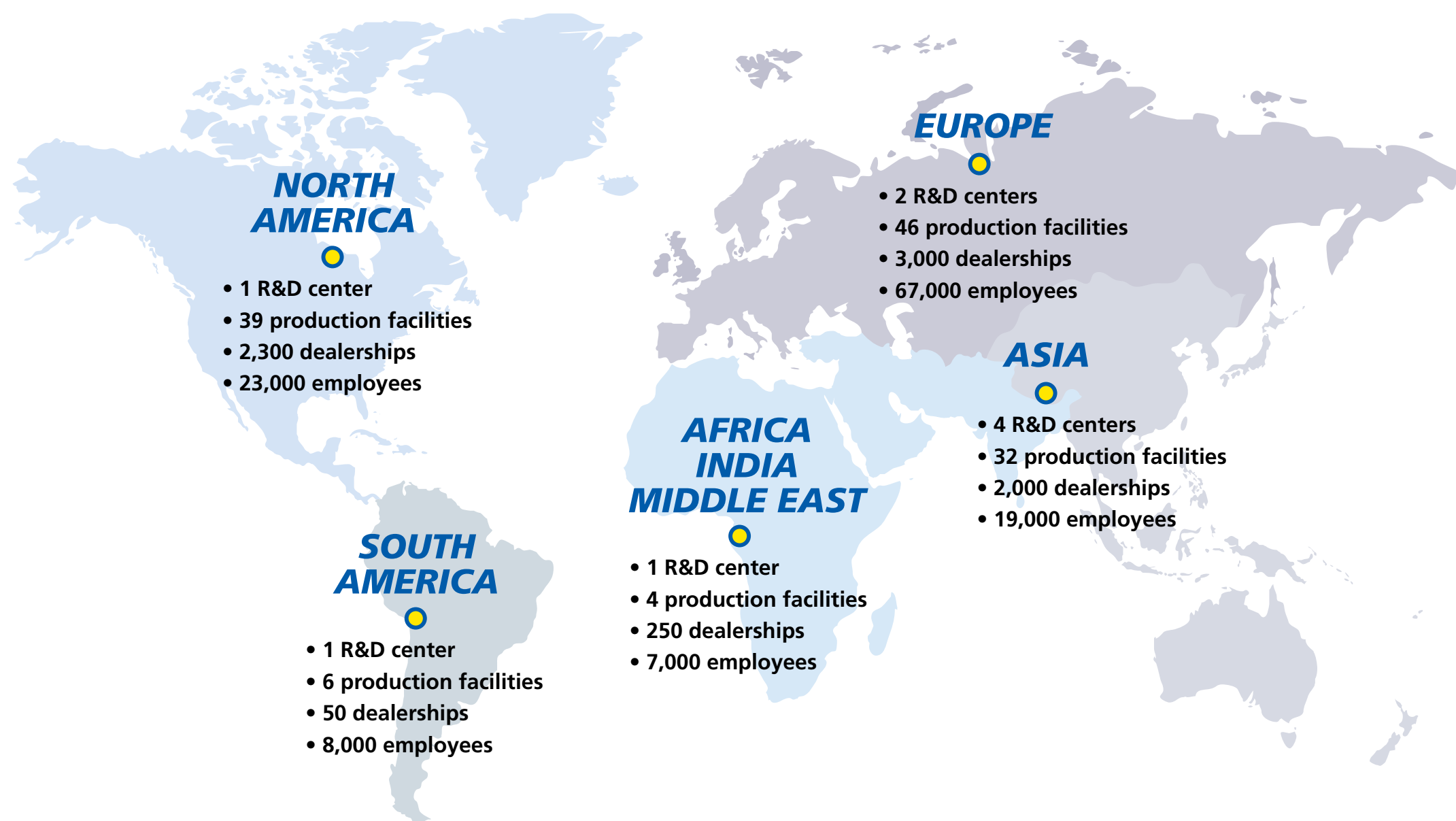

R&D
6,000
Researchers and
Technicians

Production
117
facilities in
26 countries

Dealerships
7,600
proprietary or
franchised centers
in 30 countries



GLOBAL AWARDS
RECOGNITIONS

MICHELIN GLOBAL
TECHNOLOGY CENTRE

MICHELIN
MILESTONES

GLOBAL FOOTPRINT

MICHELIN TYRE
TECHNOLOGIES

Source: 2021 Michelin Universal Registration Document

MICHELIN TYRE TECHNOLOGIES

EACH PRODUCT OFFER PACKED WITH THE LATEST MICHELIN TECHNOLOGIES TO BRING OUTSTANDING BENEFITS

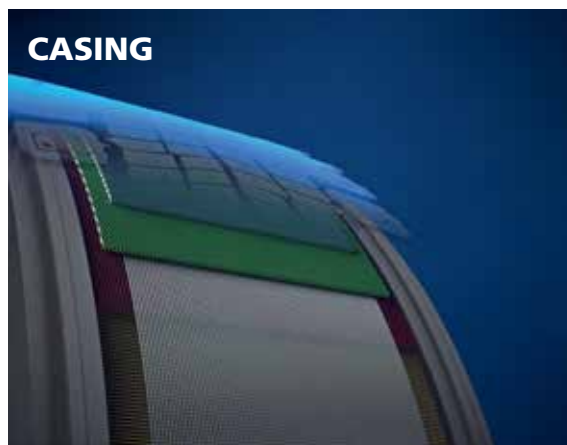

INFINICOIL: reinforced casing for greater stability and safety.

Steel wire which wraps around the casing (can measure up to 400 metres) and also provides better mileage performance.



REGENION: grip throughout the tyre's service life.

Self-regenerating tread from our moulds using 3D metal printing technology.



POWERCOIL: improved casing endurance.

New generation of cables which are more robust and resistant to oxidation.



FORCION: rubber which is more resistant for more kilometres.

New material which reinforces the rubber and increases the mileage performance.



DURACOIL: reinforced heel for better endurance.

High-quality nylon which protects the structure of the area of the tyre in contact with the wheel.

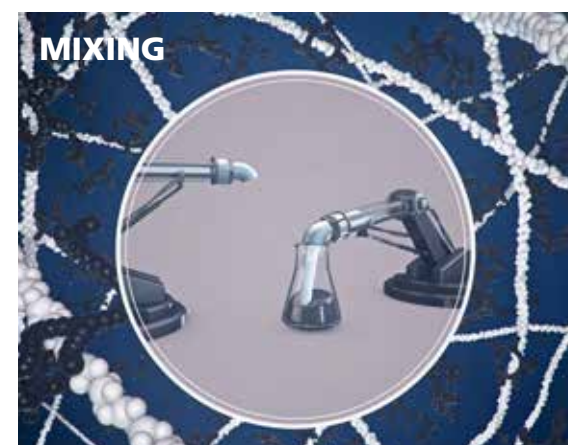

CARBION: improves the mileage longevity.

Innovative industrial process which improves the quality of the rubber mixing.

GLOBAL AWARDS RECOGNITIONS

MICHELIN GLOBAL TECHNOLOGY CENTRE

MICHELIN MILESTONES

GLOBAL FOOTPRINT

MICHELIN TYRE TECHNOLOGIES

WHY CHOOSE RADIAL OVER BIAS TYRES?

WET BRAKING Safety



Up to **25%** shorter braking distance thanks to bigger footprint

There's more rubber in contact with the road surface



WATCH THE VIDEO



DRY / WET HANDLING Safety

Flexible sidewalls to absorb Cornering stress while not sacrificing grip

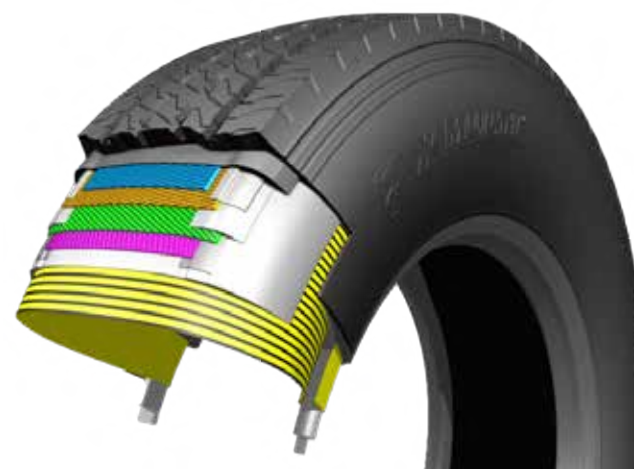

LESS DOWNTIME Productivity

Superior puncture resistance

Less pressure on the ground thus lower risk of puncture

Steel casing and crown plies to better protect

COMFORT Productivity

Protects the mechanical elements and the driver from the irregularities on the road surface

Longer endurance of the casing thanks to less overheating and better even wear

Improved mobility and steering



MICHELIN RADIAL TYRE 10 TONNE LOAD 20 KM PER HOUR

WATCH THE VIDEO



FUEL SAVING Profitability

Lower rolling resistance

WHY CHOOSE RADIAL OVER BIAS TYRES?

MICHELIN RADIAL CONSTRUCTION

READING SIDEWALL MARKINGS

HOW TO READ A TYRE SIZE

TYRE MARKING DETAILS, SPEED AND LOAD INDEX

INFLATION PRESSURE CHART

PRESSURE CONVERSION TABLES

EQUIVALENT SIZES REFERENCE

ADDITIONAL REFERENCES

MICHELIN RADIAL CONSTRUCTION

RADIAL TYRE COMPONENTS

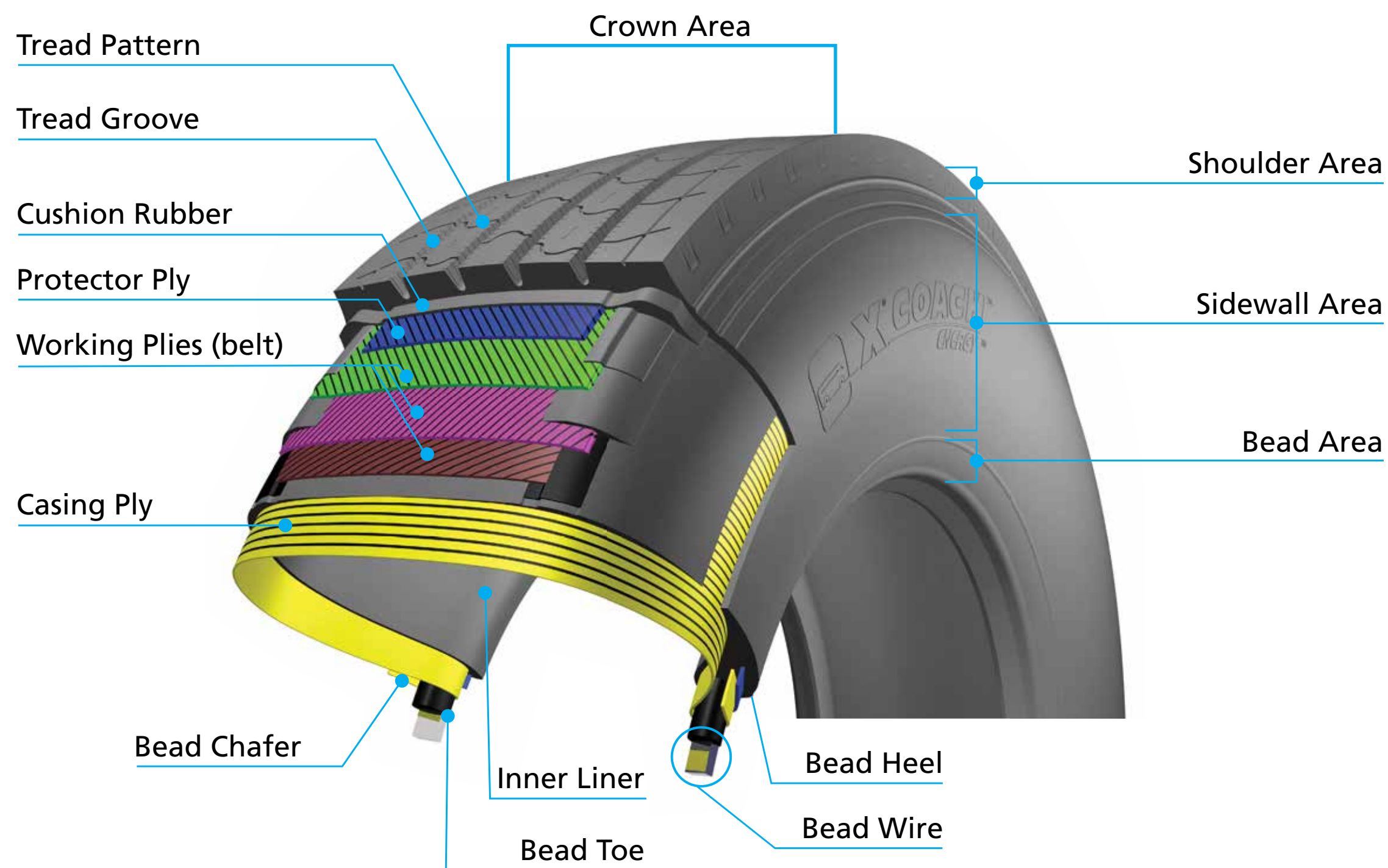

- [WHY CHOOSE RADIAL OVER BIAS TYRES?](#)
- [MICHELIN RADIAL CONSTRUCTION](#)
- [READING SIDEWALL MARKINGS](#)
- [HOW TO READ A TYRE SIZE](#)
- [TYRE MARKING DETAILS, SPEED AND LOAD INDEX](#)
- [INFLATION PRESSURE CHART](#)
- [PRESSURE CONVERSION TABLES](#)
- [EQUIVALENT SIZES REFERENCE](#)
- [ADDITIONAL REFERENCES](#)

READING SIDEWALL MARKINGS

THE MICHELIN TRUCK TYRE SIDEWALL MARKINGS TELL A LOT!

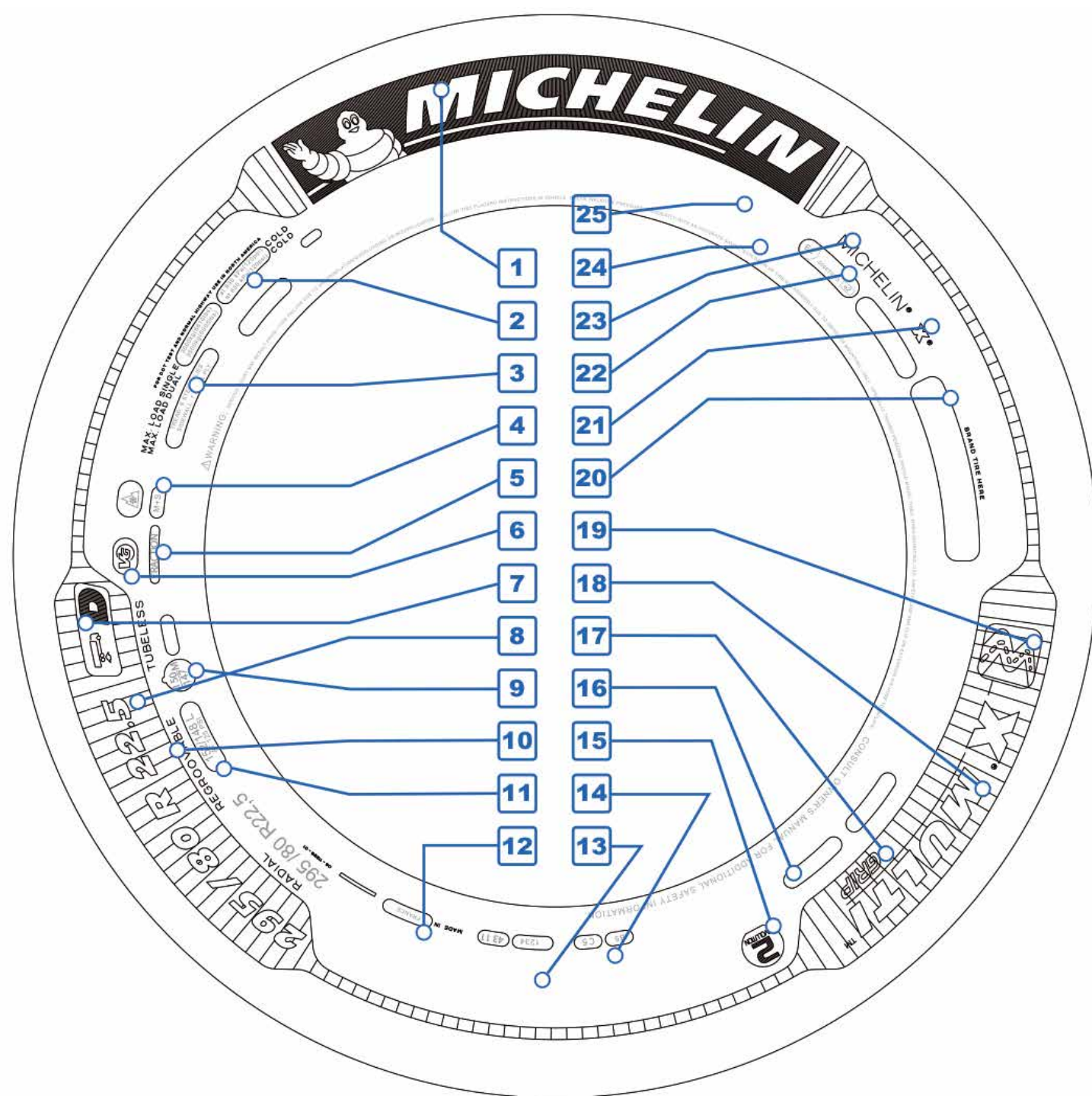

MICHELIN TRUCK TYRE SIDEWALL

- 1** MICHELIN brand logo.
- 2** Max load max press and max speed. USA regulation.
- 3** Tyre architecture.
- 4** M+S Mud and Snow & 3PMSF picto.
- 5** Traction new regulation (drive tyre) or FRT, free rolling tyre (trailer only tyre).
- 6** Specific code.
- 7** Tyre position code (Letter F for Front axle, D for Drive, T for Trailer, Z for all axle ...) illustrated on a truck silhouette (arrow indicates axle position).
- 8** Tyre Size.
- 9** Indicates added load and speed index (see chart).
- 10** Radial, tubeless, regroovable.
- 11** Load and speed index (see chart).
- 12** Made in...: indicates where the tyre has been manufactured.
- 13** Place for logistic information: vignette, barcode & matricule number, ex: PRZ6596G.
- 14** DOT: Department of transport. The last 4 numbers indicate tyre manufacturing date 43: week 11: year 2011.
- 15** Tyre evolution number: indicates production generation.
- 16** Brazil or China homologation.
- 17** Option name: indicates tyre optional benefit.
- 18** Range Name: indicates tyre usage (see naming chart).
- 19** Usage Pictogram: illustrates tyre common usage.
- 20** "Brand tire here": free space for hot branding.
- 21** X® MICHELIN radial trademark
- 22** E2...: CEE homologation number.
- 23** MICHELIN registered brand.
- 24** Warning: gives user information.
- 25** ISI Marking: In case of India homologation

WHY CHOOSE RADIAL OVER BIAS TYRES?

MICHELIN RADIAL CONSTRUCTION

READING SIDEWALL MARKINGS

HOW TO READ A TYRE SIZE

TYRE MARKING DETAILS, SPEED AND LOAD INDEX

INFLATION PRESSURE CHART

PRESSURE CONVERSION TABLES

EQUIVALENT SIZES REFERENCE

ADDITIONAL REFERENCES

HOW TO READ A TYRE SIZE

Nominal tyre cross-section in mm

STRUCTURE: "R" for radial

Nominal rim diameter in inches

ASPECT RATIO - ratio of sidewall height to nominal tyre cross-section in %.

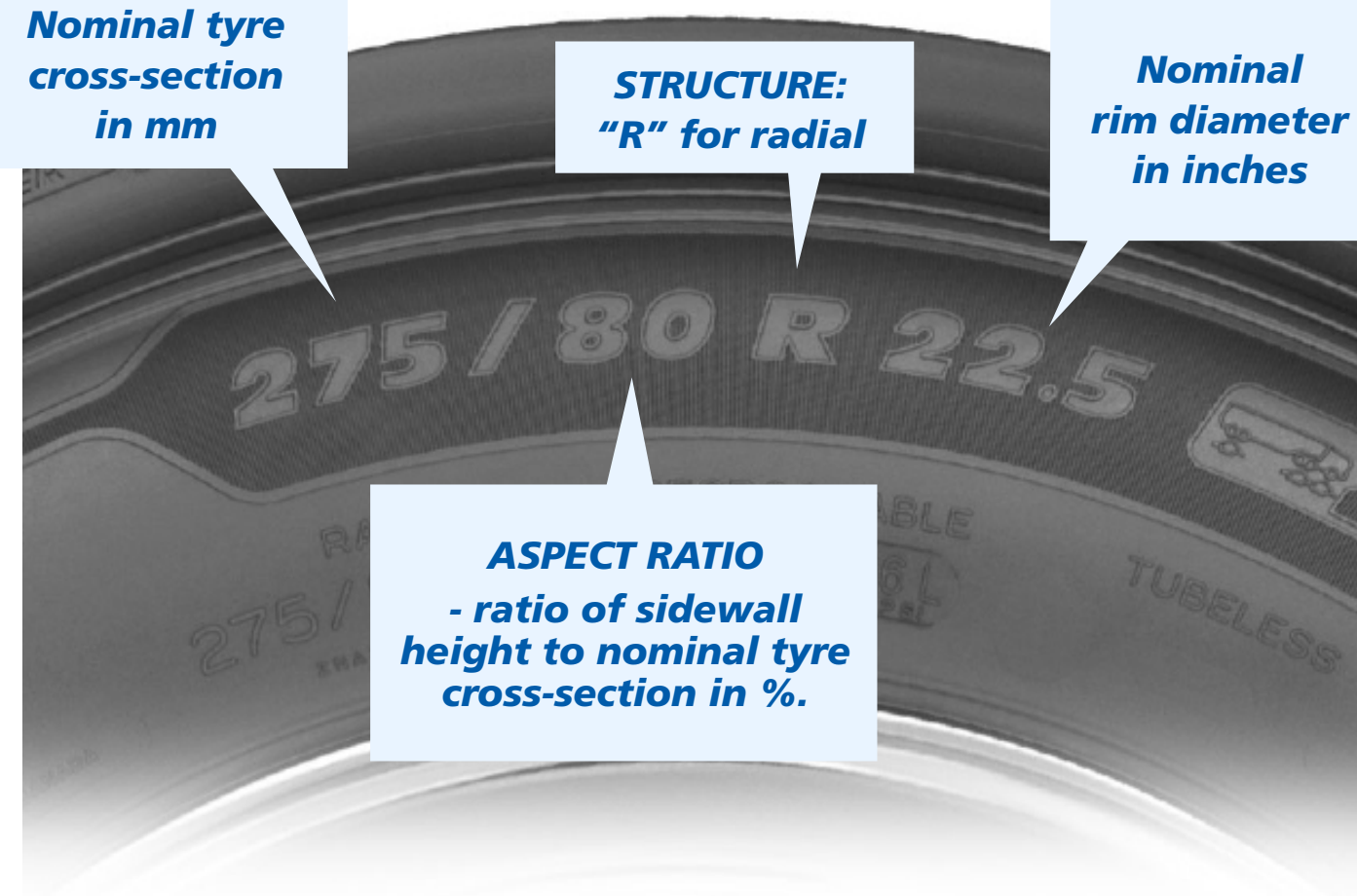

OVERALL DIMENSIONS

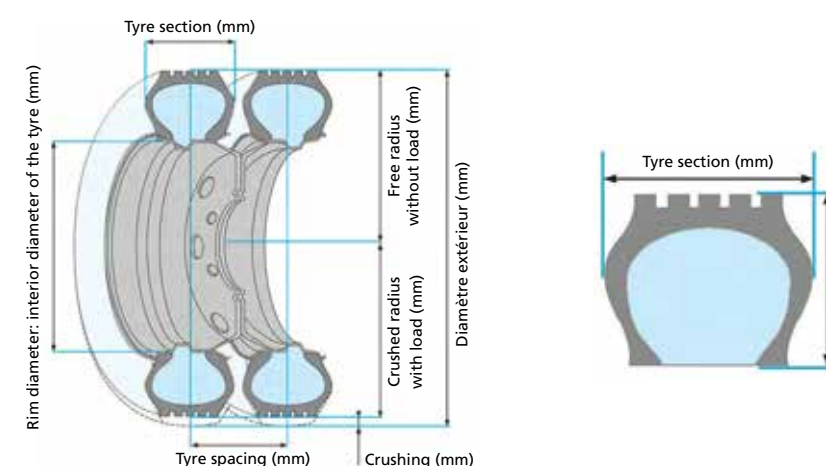

- S** Section width when measured on standard rim.
- R** Free radius.
- R'** Laden radius.
- D** Free Diameter (Rx2).
- \emptyset Rim diameter.
- E** Minimal dual spacing.
- e** Static deflection (R-R').
- H** Section height.

Load Index: These numerical values are designed to correspond to a load value listed in the table below.

Speed Symbols: These alpha numeric symbols correspond to a maximum speed the tyre is designed for continuous operation.

UNIQUE POINT

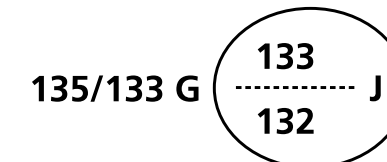

A number of truck tyre sizes carry a second load speed index marked on the sidewall. This is known as the «Unique Point» that is located after the main load index as shown below. For these sizes, the «Unique Point» provides additional load speed operating conditions in order to satisfy particular requirements.

IMPORTANT : Load variances based on speed do not apply to the additional couple load index / speed symbol of the unique point.

WHY CHOOSE RADIAL OVER BIAS TYRES?

MICHELIN RADIAL CONSTRUCTION

READING SIDEWALL MARKINGS

HOW TO READ A TYRE SIZE

TYRE MARKING DETAILS, SPEED AND LOAD INDEX

INFLATION PRESSURE CHART

PRESSURE CONVERSION TABLES

EQUIVALENT SIZES REFERENCE

ADDITIONAL REFERENCES

TYRE MARKING DETAILS, SPEED AND LOAD INDEX

SPEED SYMBOL AND LOAD INDEX

Speed Symbol	Speed		Index	Load kg	Index	Load kg	Index	Load kg	Index	Load kg
	mph	km/h								
A1	3	5	100	800	123	1550	146	3000	169	5800
A2	6	10	101	825	124	1600	147	3075	170	6000
A3	9	15	102	850	125	1650	148	3150	171	6150
A4	12	20	103	875	126	1700	149	3250	172	6300
A5	16	25	104	900	127	1750	150	3350	173	6500
A6	19	30	105	925	128	1800	151	3450	174	6700
A7	22	35	106	950	129	1850	152	3550	175	6900
A8	25	40	107	975	130	1900	153	3650	176	7100
B	31	50	108	1000	131	1950	154	3750	177	7300
C	37	60	109	1030	132	2000	155	3875	178	7500
D	40	65	110	1060	133	2060	156	4000	179	7750
E	43	70	111	1090	134	2120	157	4125	180	8000
F	50	80	112	1120	135	2180	158	4250	181	8250
G	56	90	113	1150	136	2240	159	4375	182	8500
J	62	100	114	1180	137	2300	160	4500	183	8750
K	68	110	115	1215	138	2360	161	4625	184	9000
L	74	120	116	1250	139	2430	162	4750	185	9250
M	81	130	117	1285	140	2500	163	4875	186	9500
N	87	140	118	1320	141	2575	164	5000	187	9750
			119	1360	142	2650	165	5150	188	10000
			120	1400	143	2725	166	5300	189	10300
			121	1450	144	2800	167	5450	190	10600
			122	1500	145	2900	168	5600	191	10900

Load Range	Ply Rating
A	2
B	4
C	6
D	8
E	10
F	12
G	14
H	16
J	18
L	20
M	22
N	24

Equivalence table Load / PR / LI -

The notion of PR comes from the structure of the BIAS tyres and an envelope's capacity to carry a bigger load when the tyre pressure is increased. In other words, for a given volume, (dimensional tyre box), the number of air molecules depends directly on the tyre pressure and, therefore, the load capacity.

The PR indicator is assigned to a dimension because it is dependent of the volume of air in the tyre and pressure. The conversion into Load Index (LI) of the ETRTO is made to the nearest value.

IMPORTANT: At time of fitting, it is vital that the various markings are checked, in order to be certain that the tyre is suitable for operation at the maximum allowed vehicle speed and loading.

WHY CHOOSE RADIAL OVER BIAS TYRES?

MICHELIN RADIAL CONSTRUCTION

READING SIDEWALL MARKINGS

HOW TO READ A TYRE SIZE

TYRE MARKING DETAILS, SPEED AND LOAD INDEX

INFLATION PRESSURE CHART

PRESSURE CONVERSION TABLES

EQUIVALENT SIZES REFERENCE

ADDITIONAL REFERENCES

INFLATION PRESSURE CHART

The load and inflation pressure limits indicated in the section "Dimensional data truck tyres" correspond to operating speed of 130, 120, 110, 105, 100, 80 or 65 km/h depending upon tyres and / or sizes. These limits of load and tyre pressure can vary depending on the speed.

Speed in km/h - Speed symbol	Load Capacity Variation (%)						Pressure Adjustment (%)
	F (80km/h)	G (90km/h)	J (100km/h)	K (110km/h)	L (120km/h)	M (130km/h)	
0	+150	+150	+150	+150	+150	+150	+40
5	+110	+110	+110	+110	+110	+110	+40
10	+80	+80	+80	+80	+80	+80	+30
15	+65	+65	+65	+65	+65	+65	+25
20	+50	+50	+50	+50	+50	+50	+21
25	+35	+35	+35	+35	+35	+35	+17
30	+25	+25	+25	+25	+25	+25	+13
35	+19	+19	+19	+19	+19	+19	+11
40	+15	+15	+15	+15	+15	+15	+10
45	+13	+13	+13	+13	+13	+13	+9
50	+12	+12	+12	+12	+12	+12	+8
55	+11	+11	+11	+11	+11	+11	+7
60	+10	+10	+10	+10	+10	+10	+6
65	+7.5	+8.5	+8.5	+8.5	+8.5	+8.5	+4
70	+5.0	+7.0	+7.0	+7.0	+7.0	+7.0	+2
75	+2.5	+5.5	+5.5	+5.5	+5.5	+5.5	+1
80	[0]	+4.0	+4.0	+4.0	+4.0	+4.0	0
85		+2.0	+3.0	+3.0	+3.0	+3.0	0
90		[0]	+2.0	+2.0	+2.0	+2.0	0
95			+1.0	+1.0	+1.0	+1.0	0
100			[0]	0	0	0	0
110				[0]	0	0	0
120					[0]	0	0
130						[0]	0

The coefficients given in the above table are for information only. For any modification to the basic load limits, please contact a MICHELIN Truck Tyre professional.

[WHY CHOOSE RADIAL OVER BIAS TYRES?](#)

[MICHELIN RADIAL CONSTRUCTION](#)

[READING SIDEWALL MARKINGS](#)

[HOW TO READ A TYRE SIZE](#)

[TYRE MARKING DETAILS, SPEED AND LOAD INDEX](#)

[INFLATION PRESSURE CHART](#)

[PRESSURE CONVERSION TABLES](#)

[EQUIVALENT SIZES REFERENCE](#)

[ADDITIONAL REFERENCES](#)

PRESSURE CONVERSION TABLES

Pressure Unit Conversion Table

kPa	bar	psi*	kg/cm2*
100	1.0	15	1.0
150	1.5	22	1.5
200	2.0	29	2.0
250	2.5	36	2.5
300	3.0	44	3.1
350	3.5	51	3.6
400	4.0	58	4.1
450	4.5	65	4.6
500	5.0	73	5.1
550	5.5	80	5.6
600	6.0	87	6.1
650	6.5	94	6.6
700	7.0	102	7.1
750	7.5	109	7.7
800	8.0	116	8.2
850	8.5	123	8.7
900	9.0	131	9.2
950	9.5	138	9.7
1,000	10.0	145	10.2
1,050	10.5	152	10.7

* Values in psi and kg/cm² rounded to the nearest practical units.

Adjusted Inflation Pressure (psi) when inflating indoors at 18°C

Recommended Pressure (psi)	Outside Ambient Temperature (°C)										
	10°	4°	-1°	-7°	-12°	-18°	-23°	-29°	-34°	-40°	-46°
75	78	80	81	83	86	88	90	92	95	98	100
80	83	85	87	89	91	93	96	98	101	104	107
85	88	90	92	94	97	99	102	104	107	110	113
90	93	95	98	100	102	105	108	110	113	116	119
95	98	101	103	105	108	111	113	116	119	123	126
100	103	106	108	111	113	116	119	122	125	129	132
105	109	111	114	116	119	122	125	128	132	135	139
110	114	116	119	122	125	128	131	134	138	141	145
115	119	122	124	127	130	133	137	140	144	148	151
120	124	127	130	133	136	139	143	146	150	154	158
125	129	132	135	138	141	145	148	152	156	160	164
130	134	137	140	144	147	150	154	158	162	166	171

Failure to follow these recommendations may lead to a reduction in the performance your vehicle and cause it to respond abnormally and/or a tyre could pose a safety risk to the user and others. Michelin shall not be responsible under any circumstances for damage that occurs as a result of and/or during use that does not comply with its guidelines.



WHY CHOOSE RADIAL OVER BIAS TYRES?

MICHELIN RADIAL CONSTRUCTION

READING SIDEWALL MARKINGS

HOW TO READ A TYRE SIZE

TYRE MARKING DETAILS, SPEED AND LOAD INDEX

INFLATION PRESSURE CHART

PRESSURE CONVERSION TABLES

EQUIVALENT SIZES REFERENCE

ADDITIONAL REFERENCES

EQUIVALENT SIZES REFERENCE

Equivalent Sizes

100 Series	90 Series	Low Profile Series
7.50 R 15		215/75 R 17.5
8.25 R 15	9 R 17.5	235/75 R 17.5
10.00 R 15		285/70 R 19.5
7.00 R 16	8 R 17.5	205/75 R 17.5
7.50 R 16	8.5 R 17.5	215/75 R 17.5
		225/75 R 17.5
		225/80 R 17.5
8.25 R 16	9.5 R 17.5	235/75 R 17.5 245/70 R 19.5
	10 R 17.5	
	225/90 R 17.5	
7.50 R 20	8 R 22.5	
8.25 R 20	9 R 22.5	
9.00 R 20	10 R 22.5	255/70 R 22.5
		275/70 R 22.5
10.00 R 20	11 R 22.5	295/80 R 22.5
		275/80 R 22.5
		275/70 R 22.5
11.00 R 20	12 R 22.5	295/80 R 22.5
		315/80 R 22.5
		305/70 R 22.5
		315/70 R 22.5
12.00 R 20	13 R 22.5	315/80 R 22.5

Note : Before any change over please check :

- Load capacity
- Vehicle clearance
- Recommended rim/wheel
- Dual spacing

WHY CHOOSE RADIAL OVER BIAS TYRES?

MICHELIN RADIAL CONSTRUCTION

READING SIDEWALL MARKINGS

HOW TO READ A TYRE SIZE

TYRE MARKING DETAILS, SPEED AND LOAD INDEX

INFLATION PRESSURE CHART

PRESSURE CONVERSION TABLES

EQUIVALENT SIZES REFERENCE

ADDITIONAL REFERENCES

ADDITIONAL REFERENCES

General Note

The indicated values are for guidance only and may not be used for regulatory or legal purposes.

(1) ETRTO dimensions

ETRTO dimensions, values measured on the nominal rim. These values are provided by way of indication. All MICHELIN tyres are designed according to ETRTO, JATMA or TRA defined international standards.

ETRTO = European Tyre and Rim Technical Organisation.

JATMA = Japan Automobile Tyre Manufacturers Association, Inc.

TRA = Tire and Rim Association, Inc.

S = MAXIMUM in service overall width.

D = MAXIMUM in service overall diameter.

R.C (*Cdr*) = Rolling circumference calculated from the design diameter in nominal conditions of load, speed and pressure.

(2) MICHELIN tyre dimensions

MICHELIN dimensions, value measured on the nominal rim in nominal conditions of load, speed and pressure.

S = DESIGN overall width (For Special Uses Tyre Only).

D = DESIGN overall diameter (For Special Uses Tyre Only).

RC = Rolling circumference calculated from the design diameter.

R' = Static laden radius.

E = Minimum distance between dual on the advised rim.

(3) Advised rims

ETRTO recommendations, the advised rim (or nominative rim) is in bold characters.

(4) Advised flaps (new flaps 2000)

MICHELIN recommended flap(s) for a TT (Tube Type) fitting. The former flap designation and the new flap designation integrate since 2000, the seat diameter and the rim width. Flaps designation with a « D » letter have an offset valve hole. Check, before fitting, that you have the correct offset for the valve hole in the rim compatible with this flap.

(5) Tube or seal

MICHELIN recommended tube(s) reference(s) for a TT (Tube Type) fitting. MICHELIN recommended seal references for a TL (Tubeless) fitting.

(6) LR «X»

Load range with a letter to indicate load index. Concerns American tyres.

(7) Seal 1786 for TL on flat base rim

(8) Seal TYRAN 1443 for TL on flat rim

(9) Seal SPRAT R1014 for TL on flat rim

(10) Without

(11) O'Ring 1681 for TL on SDC rim

(12) O'Ring OR 6.6-21 R1506

(13) No longer manufactured

[WHY CHOOSE RADIAL OVER BIAS TYRES?](#)[MICHELIN RADIAL CONSTRUCTION](#)[READING SIDEWALL MARKINGS](#)[HOW TO READ A TYRE SIZE](#)[TYRE MARKING DETAILS, SPEED AND LOAD INDEX](#)[INFLATION PRESSURE CHART](#)[PRESSURE CONVERSION TABLES](#)[EQUIVALENT SIZES REFERENCE](#)[ADDITIONAL REFERENCES](#)

CHOOSING THE RIGHT MICHELIN TYRE

FAMILIARIZING THE MICHELIN TYRE NAMING

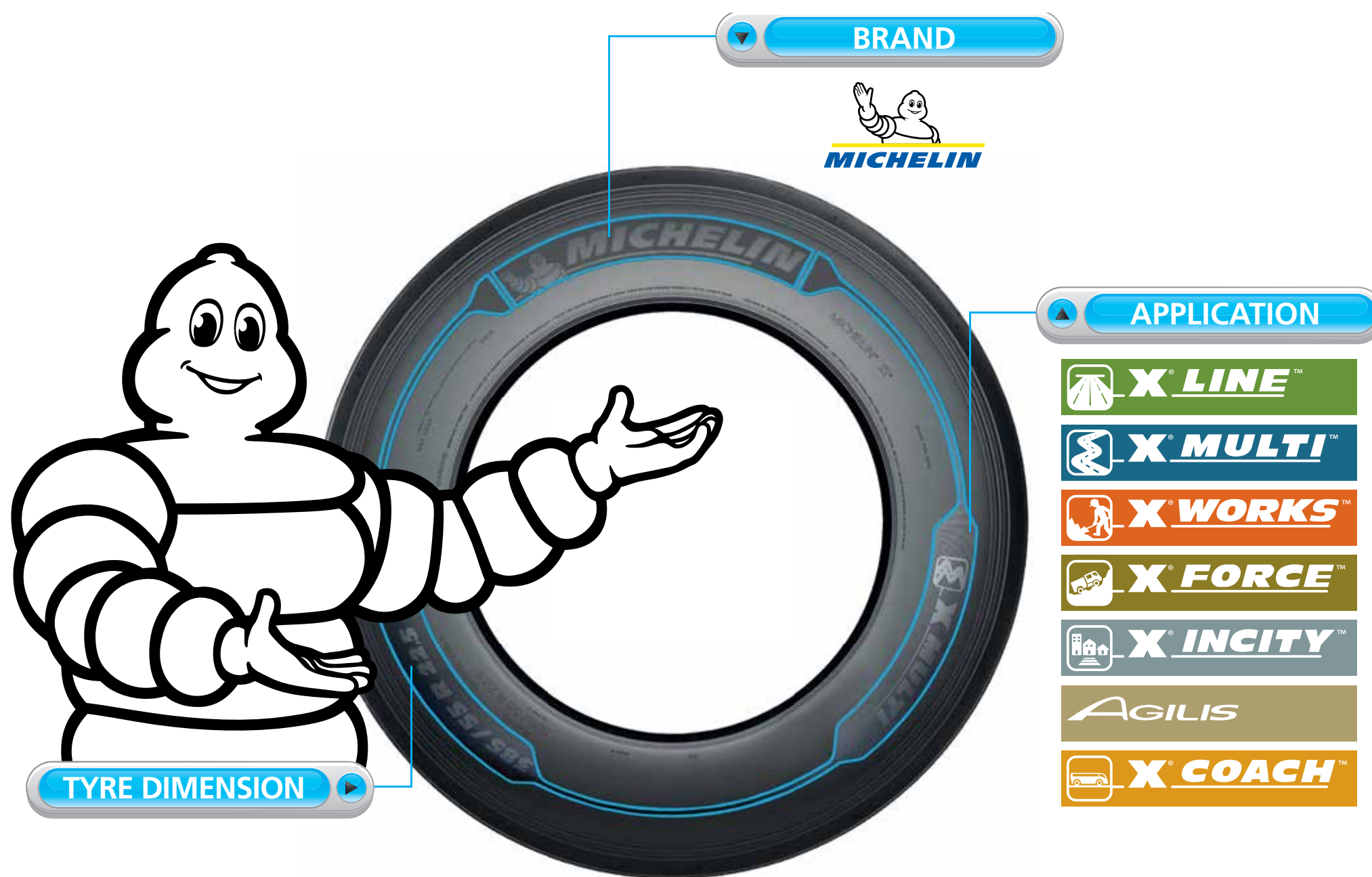

- Z = All Position**
- F = Front (Steer)(a)**
- D = Drive (b)**
- T = Trailer (c)**

- FAMILIARIZING THE MICHELIN TYRE NAMING
- DEFINE THE RIGHT TYRE FOR THE CUSTOMER
- READING THE PRODUCT NAME AND TARGET VOCATIONS
- IDENTIFYING THE KEY CUSTOMER VALUE PROPOSITION
- SELECTING THE RIGHT TREAD PATTERN

CHOOSING THE RIGHT MICHELIN TYRE

DEFINE THE RIGHT TYRE FOR THE CUSTOMER

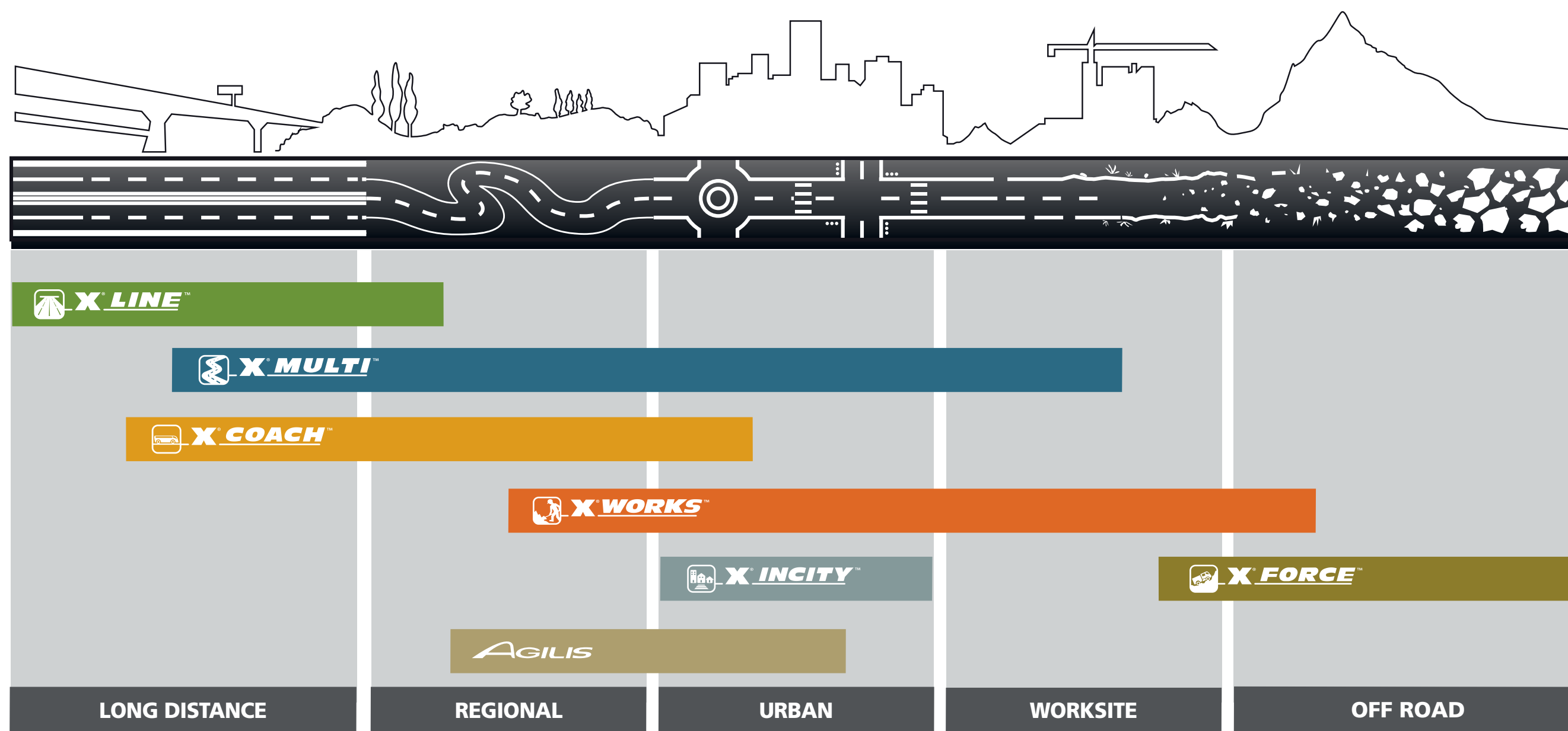

FAMILIARIZING THE MICHELIN TYRE NAMING

DEFINE THE RIGHT TYRE FOR THE CUSTOMER

READING THE PRODUCT NAME AND TARGET VOCATIONS

IDENTIFYING THE KEY CUSTOMER VALUE PROPOSITION

SELECTING THE RIGHT TREAD PATTERN

X LINE LONG DISTANCE, HIGH AVERAGE SPEED, INTERNATIONAL JOURNEYS, CONSTANT SPEED

X MULTI DESIGNED FOR NATIONAL AND REGIONAL OPERATIONS ON ALL TYPES OF ROAD

X WORKS ON ROAD, IN AND AROUND WORKSITES AND QUARRIES

AGILIS VAN AND COMMERCIAL LIGHT TRUCK TYRE

X COACH DESIGNED FOR NATIONAL AND REGIONAL OPERATIONS ON ALL TYPES OF ROAD

X INCITY FOR URBAN APPLICATIONS

X FORCE SPECIALLY DESIGNED FOR OFF-ON ROAD VEHICLES THAT DRIVE ON ALL TERRAINS AND REQUIRE MAXIMUM MOBILITY

CHOOSING THE RIGHT MICHELIN TYRE

READING THE PRODUCT NAME AND TARGET VOCATIONS

MICHELIN is progressively replacing the traditional application designations with a new naming designation

MICHELIN X[®] MULTI[™] Z 2

Brand

Range

Position

Evolution

For example

MICHELIN Radial

X[®] = MICHELIN Radial Tyre





Application

- A =  = Motorways
- E =  = Regional Roads
- Y =  = On/Off Road Use
- L =  = Off Road Use
- U =  = Urban Use
-  = Coach Vehicle Use
-  = Light Truck and Minibus

Benefit

- TROPIC = High Performance for Hot Climate
- ENERGY = Fuel Efficiency
- GRIP = All season Grip
- HD = Heavy Duty
- HL = Extra Load













Position

-  Z = All Position
-  F = Front (Steer) (a)
-  D = Drive (b)
-  T = Trailer (c)

Index

Number at the end of the designation used to denote product evolution or attributes

Product Segmentation

Segment	Application*	Pictograms	Vocations
Long Haul	A 		- Long haul transport (general freight, parcel distribution)
Regional Roads	E 		- Public Utilities - Food Distribution - Petroleum Delivery - Courier & Delivery Service - Auto Carriers - X MULTI HD on severe and off road
On/Off Road Use	Y 		- Construction & Mining - Forestry & Logging - Oil Field
Off Road Use	L M S 		- Military and emergency services
Urban Use	U 		- Urban Buses - Sanitation & Refuse
Coach Vehicle Use Bus			- Medium & Long Distance, People Transportation
Light Truck Vehicle			- LT Agilis on road short and long distance - Agilis HD on severe and off road

IMPORTANT : MICHELIN is not responsible or liable for any damage due to utilization outside of technical advice..

* A, E, Y, L, U = Traditional Application Designations

X[®] LINE[™], X[®] MULTI[™], X[®] WORKS[™], X[®] FORCE[™], X[®] INCITY[™], X[®] COACH[™] = New Application Designations

a : Usage of front axle tyre («F») on drive axle could give poor longitudinal grip performance and low mileage.

b : Usage of drive axle tyre («D») on front axle could give uneven wear and poor driving comfort.

c : Some tyres which have additional marking FRT (Free Rolling Tyre) are developed specially for trailer and semi-trailer fitments and NOT allowed to be fitted on front axle.

FAMILIARIZING THE MICHELIN TYRE NAMING

DEFINE THE RIGHT TYRE FOR THE CUSTOMER

READING THE PRODUCT NAME AND TARGET VOCATIONS

IDENTIFYING THE KEY CUSTOMER VALUE PROPOSITION

SELECTING THE RIGHT TREAD PATTERN

CHOOSING THE RIGHT MICHELIN TYRE

IDENTIFYING THE KEY CUSTOMER VALUE PROPOSITION

MICHELIN TYRES OFFER DIFFERENT BENEFITS DEPENDING ON THE USER'S SPECIFIC NEEDS.

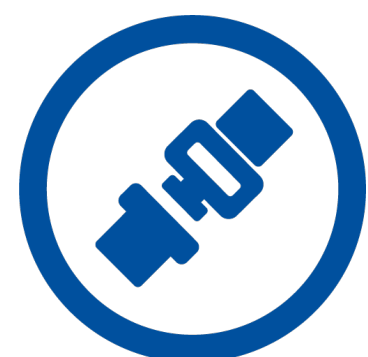

SAFETY



PRODUCTIVITY



COST

SELECTING THE RIGHT TREAD PATTERN

THERE ARE RULES WHICH MUST BE FOLLOWED WHEN SELECTING THE TREAD PATTERNS OF YOUR TYRES.



FAMILIARIZING THE MICHELIN TYRE NAMING

DEFINE THE RIGHT TYRE FOR THE CUSTOMER

READING THE PRODUCT NAME AND TARGET VOCATIONS

IDENTIFYING THE KEY CUSTOMER VALUE PROPOSITION

SELECTING THE RIGHT TREAD PATTERN

MICHELIN TYRES FOR E2A MARKETS



LONG DISTANCE, HIGH AVERAGE SPEED, INTERNATIONAL JOURNEYS, CONSTANT SPEED



- X LINE
- X MULTI
- X WORKS
- X FORCE
- X INCITY
- X COACH
- COMMERCIAL LIGHT TRUCK TYRES



MICHELIN X LINE Z



MICHELIN X LINE F



MICHELIN X LINE T



MICHELIN X LINE ENERGY D

• MICHELIN truck tyres are designed and optimized for specific conditions of usage. It is therefore not advisable to use the product in conditions of use outside the parameters for which it was designed for. Operations outside these parameters are identified as abnormal usage and are not eligible for warranty consideration. Serious or fatal injury may result from tyre failure as a result of operating outside the tyres intended conditions of use. Consult your MICHELIN Truck Tyre professionals for recommendations and procedures.

MICHELIN TYRES FOR E2A MARKETS



DESIGNED FOR NATIONAL AND REGIONAL OPERATIONS ON ALL TYPES OF ROAD



- [X LINE](#)
- [X MULTI](#)
- [X WORKS](#)
- [X FORCE](#)
- [X INCITY](#)
- [X COACH](#)
- [COMMERCIAL LIGHT TRUCK TYRES](#)



MICHELIN X MULTI Z



MICHELIN X MULTI Z2



MICHELIN X MULTI ENERGY Z



MICHELIN X MULTI D



MICHELIN X MULTI D+



MICHELIN X MULTI F



MICHELIN X MULTI GRIP Z



MICHELIN X MULTI HL Z



MICHELIN X MULTI T



MICHELIN X MULTI T2

• MICHELIN truck tyres are designed and optimized for specific conditions of usage. It is therefore not advisable to use the product in conditions of use outside the parameters for which it was designed for. Operations outside these parameters are identified as abnormal usage and are not eligible for warranty consideration. Serious or fatal injury may result from tyre failure as a result of operating outside the tyres intended conditions of use. Consult your MICHELIN Truck Tyre professionals for recommendations and procedures.

MICHELIN TYRES FOR E2A MARKETS



ON ROAD, IN AND AROUND WORKSITES AND QUARRIES



MICHELIN X WORKS Z



MICHELIN X WORKS D



MICHELIN X WORKS XTY 2



MICHELIN X WORKS HD Z



MICHELIN X WORKS HD D



MICHELIN X WORKS Z2



MICHELIN X WORKS D2

- [X LINE](#)
- [X MULTI](#)
- [X WORKS](#)
- [X FORCE](#)
- [X INCITY](#)
- [X COACH](#)
- [COMMERCIAL LIGHT TRUCK TYRES](#)

• MICHELIN truck tyres are designed and optimized for specific conditions of usage. It is therefore not advisable to use the product in conditions of use outside the parameters for which it was designed for. Operations outside these parameters are identified as abnormal usage and are not eligible for warranty consideration. Serious or fatal injury may result from tyre failure as a result of operating outside the tyres intended conditions of use. Consult your MICHELIN Truck Tyre professionals for recommendations and procedures.

MICHELIN TYRES FOR E2A MARKETS



SPECIALLY DESIGNED FOR OFF-ON ROAD VEHICLES THAT DRIVE ON ALL TERRAINS AND REQUIRE MAXIMUM MOBILITY



MICHELIN XZL 2



MICHELIN XZL+



MICHELIN XZL



MICHELIN XML



MICHELIN X FORCE ZL



MICHELIN X FORCE S



MICHELIN X FORCE ML



MICHELIN X FORCE ZH

X LINE

X MULTI

X WORKS

X FORCE

X INCITY

X COACH

COMMERCIAL LIGHT TRUCK TYRES

• MICHELIN truck tyres are designed and optimized for specific conditions of usage. It is therefore not advisable to use the product in conditions of use outside the parameters for which it was designed for. Operations outside these parameters are identified as abnormal usage and are not eligible for warranty consideration. Serious or fatal injury may result from tyre failure as a result of operating outside the tyres intended conditions of use. Consult your MICHELIN Truck Tyre professionals for recommendations and procedures.

MICHELIN TYRES FOR E2A MARKETS



FOR URBAN APPLICATIONS



MICHELIN X INCITY Z



MICHELIN X INCITY XZU3+



MICHELIN X INCITY EV Z

- [X LINE](#)
- [X MULTI](#)
- [X WORKS](#)
- [X FORCE](#)
- [X INCITY](#)
- [X COACH](#)
- [COMMERCIAL LIGHT TRUCK TYRES](#)

• MICHELIN truck tyres are designed and optimized for specific conditions of usage. It is therefore not advisable to use the product in conditions of use outside the parameters for which it was designed for. Operations outside these parameters are identified as abnormal usage and are not eligible for warranty consideration. Serious or fatal injury may result from tyre failure as a result of operating outside the tyres intended conditions of use. Consult your MICHELIN Truck Tyre professionals for recommendations and procedures.

MICHELIN TYRES FOR E2A MARKETS



DESIGNED FOR NATIONAL AND REGIONAL OPERATIONS ON ALL TYPES OF ROAD



MICHELIN X COACH XD



MICHELIN X COACH Z

- [X LINE](#)
- [X MULTI](#)
- [X WORKS](#)
- [X FORCE](#)
- [X INCITY](#)
- [X COACH](#)
- [COMMERCIAL LIGHT TRUCK TYRES](#)

• MICHELIN truck tyres are designed and optimized for specific conditions of usage. It is therefore not advisable to use the product in conditions of use outside the parameters for which it was designed for. Operations outside these parameters are identified as abnormal usage and are not eligible for warranty consideration. Serious or fatal injury may result from tyre failure as a result of operating outside the tyres intended conditions of use. Consult your MICHELIN Truck Tyre professionals for recommendations and procedures.

MICHELIN TYRES FOR E2A MARKETS

COMMERCIAL LIGHT TRUCK TYRES

FOR VANS, PICKS UP AND MEDIUM-LIGHT TRUCKS



COMMERCIAL LIGHT TRUCK TYRES



MICHELIN XCD2



MICHELIN AGILIS



MICHELIN AGILIS 3



MICHELIN AGILIS CROSS CLIMATE



MICHELIN AGILIS CAMPING



MICHELIN AGILIS X-ICE

MEDIUM-LIGHT TRUCK TYRES



MICHELIN AGILIS LT



MICHELIN AGILIS HD



MICHELIN XJE 4 MIX



MICHELIN X MULTI Z



MICHELIN X MULTI HD Z



MICHELIN X MULTI D

X LINE

X MULTI

X WORKS

X FORCE

X INCITY

X COACH

COMMERCIAL LIGHT TRUCK TYRES

• MICHELIN truck tyres are designed and optimized for specific conditions of usage. It is therefore not advisable to use the product in conditions of use outside the parameters for which it was designed for. Operations outside these parameters are identified as abnormal usage and are not eligible for warranty consideration. Serious or fatal injury may result from tyre failure as a result of operating outside the tyres intended conditions of use. Consult your MICHELIN Truck Tyre professionals for recommendations and procedures.

MICHELIN DIMENSIONAL DATA

15-16 INCHES

Dimension	Tread Pattern	Category	Type	PR (Ply Rating)	Load / Speed Index	Unique point (3)	Normal pressure for unique point (bar)	Original tread depth	Nominal load per axle (single) (kg)	Nominal pressure for load (single) (bar)	Nominal load per axle (dual) (kg)	Nominal pressure for load (dual) (bar)	Maximum section width in service (mm)	Maximum diameter in service (mm) (1)	Rolling circumference (mm)	Approved rim(s) ETRTO	Laden section width (mm) (2)	Free section width (mm) (2)	Diameter (mm) (2)	Static laden radius (mm) (2)	Rolling circumference (mm) (2)	Minimum dual spacing (mm) (2)	Recommended rim(s) by MICHELIN	Tube	Flap	Seal
7.50R15	XTA	2	TT	16	135/133G	133/132J	8.50	10.5	4360	8.50	8240	8.50	220	787	2385	6.0-6.5-B6.5	233	210	769	354	2340	238	6.00	15/16 J	15x6.00	
8.25R15	XTA	2	TT		143/141G	141/140J	8.50	11.2	5450	8.50	10300	8.50	246	853	2585	6.0-6.5 B6.5-6.50	259	232	834	381	2547	262	6.50	15K	15x6.00	
10.00R15	XTA	2	TT	18	148/145G	146/144J	8.50	11.5	6300	8.50	11600	8.50	286	939	2845	7.0 - 7.5	298	269	914	419	2780	304	7.50	15P	15x7.50	
205/75R16	XDW ICE GRIP	7	TL		113/111L			11.9	2300	6.00	4360	6.00	213	726	2200	5.50 JJ-6 JJ 5.50 K-6.5JJ	217	199	721	337	2207	225	5.50JJ			
195/85R16	XJE4 MIX ENERGY	7	TL		114/112L			8.5	2360	6.00	4480	6.00	206	751	2276	5J - 5 1/2J 6J - 6K	217	197	733	343.5	2241	223	5.50JK			
195/85R16	XDW ICE GRIP	7	TL		114/112L			11.8	2360	6.00	4480	6.00	206	751	2276	5 J-5.50 JJ-6 JJ 5 K-5.50 K-6 K	219	197	742	347	2270	223	5.50 JJ			
205/85R16	XJE4 MIX ENERGY	7	TL		117/115L			8.6	2570	6.00	4860	6.00	213	768	2327	5-5.5-6-6.5	233	211	752	352	2297	239	6.00			
	XDW ICE GRIP	7	TL		117/115L			11.9	2570	6.00	4860	6.00	213	768	2327	5J à 61/2K	231	211	761	356	2330	239	6.00JK			
215/85R16	XJE4 MIX ENERGY	7	TL		120/118L			9.0	2800	6.00	5280	6.00	227	787	2385	5.5-6-6.5 - 7.0	241	219	769	358	2350	247	6.00JK			

• (1) ETRTO rating (standard value, the ETRTO standard rim may be different to the rim recommended by MICHELIN). • (2) MICHELIN rating, value measured on rim recommended by MICHELIN. • (3) Unique point: load capacity/authorized additional speed pair Load variations according to speed do not apply to the unique point.

See the next table for the recommended inflation pressure

- 15-16 INCHES
- 17.5 INCHES
- 19.5 INCHES
- 20 INCHES
- 20 AND 24 INCHES
- 19.5 AND 22.5 INCHES WIDEBASE
- 22.5 INCHES
- OFF-ROAD SIZES
- MICHELIN AGILIS 3 SIZES
- MICHELIN XCD2 SIZES

MICHELIN DIMENSIONAL DATA

15-16 INCHES

Table of inflation pressure (bar) in relation to maximum load per axle (kg)

Dimension	Tread pattern	Table of inflation pressure (bar) in relation to maximum load per axle (kg)																											
		psi	36	40	44	47	51	54	58	62	65	69	73	76	80	83	87	91	94	98	102	105	109	112	116	120	123	127	131
		bar	2.50	2.75	3.00	3.25	3.50	3.75	4.00	4.25	4.50	4.75	5.00	5.25	5.50	5.75	6.00	6.25	6.50	6.75	7.00	7.25	7.50	7.75	8.00	8.25	8.50	8.75	9.00
7.50R15	XTA	single													2950	3060	3180	3300	3420	3540	3650	3770	3890	4010	4120	4240	4360		
		dual														5570	5790	6010	6240	6460	6680	6900	7130	7350	7570	7790	8020	8240	
8.25R15	XTA	single													3680	3830	3980	4120	4270	4420	4570	4710	4860	5010	5160	5300	5450		
		dual														6960	7240	7520	7790	8070	8350	8630	8910	9190	9460	9740	10020	10300	
10.00R15	XTA	single													4260	4430	4600	4770	4940	5110	5280	5450	5620	5790	5960	6130	6300		
		dual														7840	8150	8460	8780	9090	9410	9720	10030	10350	10660	10970	11290	11600	
205/75R16	XDW ICE GRIP	single			1280	1360	1450	1530	1620	1700	1790	1870	1960	2040	2130	2210	2300												
		dual			2420	2580	2750	2910	3070	3230	3390	3550	3710	3880	4040	4200	4360												
195/85R16	XJE4 MIX ENERGY	single			1310	1400	1490	1570	1660	1750	1840	1920	2010	2100	2190	2270	2360												
		dual			2490	2650	2820	2990	3150	3320	3480	3650	3820	3980	4150	4310	4480												
195/85R16	XDW ICE GRIP	single			1310	1400	1490	1570	1660	1750	1840	1920	2010	2100	2190	2270	2360												
		dual			2490	2650	2820	2990	3150	3320	3480	3650	3820	3980	4150	4310	4480												
205/85R16	XJE4 MIX ENERGY	single			1430	1520	1620	1710	1810	1900	2000	2090	2190	2280	2380	2470	2570												
		dual			2700	2880	3060	3240	3420	3600	3780	3960	4140	4320	4500	4680	4860												
	XDW ICE GRIP	single			1430	1520	1620	1710	1810	1900	2000	2090	2190	2280	2380	2470	2570												
		dual			2700	2880	3060	3240	3420	3600	3780	3960	4140	4320	4500	4680	4860												
215/85R16	XJE4 MIX ENERGY	single			1560	1660	1760	1870	1970	2070	2180	2280	2390	2490	2590	2700	2800												
		dual			2930	3130	3320	3520	3720	3910	4110	4300	4500	4690	4890	5080	5280												

- 15-16 INCHES
- 17.5 INCHES
- 19.5 INCHES
- 20 INCHES
- 20 AND 24 INCHES
- 19.5 AND 22.5 INCHES WIDEBASE
- 22.5 INCHES
- OFF-ROAD SIZES
- MICHELIN AGILIS 3 SIZES
- MICHELIN XCD2 SIZES

Dimensional data for general indication only, for official data consult MICHELIN Technical Correspondent.

MICHELIN DIMENSIONAL DATA

15-16 INCHES

Dimension	Tread Pattern	Category	Type	PR (Ply Rating)	Load / Speed Index	Unique point (3)	Normal pressure for unique point (bar)	Original tread depth	Nominal load per axle (single) (kg)	Nominal pressure for load (single) (bar)	Nominal load per axle (dual) (kg)	Nominal pressure for load (dual) (bar)	Maximum section width in service (mm)	Maximum diameter in service (mm) (1)	Rolling circumference (mm)	Approved rim(s) ETRTO	Laden section width (mm) (2)	Free section width (mm) (2)	Diameter (mm) (2)	Static laden radius (mm) (2)	Rolling circumference (mm) (2)	Minimum dual spacing (mm) (2)	Recommended rim(s) by MICHELIN	Tube	Flap	Seal
7.00 R16	AGILIS	7	TL	16	117/113L			9.2	2570	6.00	4600	6.00	208	794	2406	4.50E - 5.00E 5.50F - 6.00G	217	195	782	365.5	2388	221	5.50F	16J	16x6.00	
	AGILIS	7	TL	12	117/116L			9.2	2570	6.00	5000	6.00	208	794	2406	4.50E - 5.00E 5.50F - 6.00G	217	195	782	365	2388	221	5.50F	16J	16x6.00	
7.50R16	AGILIS	7	TL	14	122/121L			9.2	3000	7.00	5800	7.00	226	824	2497	5.50F - 6.00G 6.50H	231	209	800	375	2450	237	6.00G	16J	16x6.00	
	AGILIS HD	7	TL	14	122/121L			10.3	3000	7.00	5800	7.00	226	824	2497	5.50F - 6.00G 6.50H	227	207	804	377	2459	234	6.00G	16J	16x6.00	
8.25R16	AGILIS	7	TT	16	128/126K			10.5	3600	6.75	6800	6.75	239	878	2623	6.00G - 6.50H	256	232	858	400	2619	263	6.50H	16K	16x6.00	
	AGILIS HD	7	TT	16	128/126K			11.6	3600	6.75	6800	6.75	239	878	2623	6.00G - 6.50H	259	235	860	400.5	2627	265	6.50H	16K	16x6.00	

• (1) ETRTO rating (standard value, the ETRTO standard rim may be different to the rim recommended by MICHELIN). • (2) MICHELIN rating, value measured on rim recommended by MICHELIN. • (3) Unique point: load capacity/authorized additional speed pair Load variations according to speed do not apply to the unique point.

See the next table for the recommended inflation pressure

- 15-16 INCHES
- 17.5 INCHES
- 19.5 INCHES
- 20 INCHES
- 20 AND 24 INCHES
- 19.5 AND 22.5 INCHES WIDEBASE
- 22.5 INCHES
- OFF-ROAD SIZES
- MICHELIN AGILIS 3 SIZES
- MICHELIN XCD2 SIZES

MICHELIN DIMENSIONAL DATA

15-16 INCHES

Table of inflation pressure (bar) in relation to maximum load per axle (kg)

Dimension	Tread pattern	psi	36	40	44	47	51	54	58	62	65	69	73	76	80	83	87	91	94	98	102	105	109	112	116	120	123	127	131	
		bar	2.50	2.75	3.00	3.25	3.50	3.75	4.00	4.25	4.50	4.75	5.00	5.25	5.50	5.75	6.00	6.25	6.50	6.75	7.00	7.25	7.50	7.75	8.00	8.25	8.50	8.75	9.00	
		7.00 R16	AGILIS	single			1430	1520	1620	1710	1810	1900	2000	2090	2190	2280	2380	2470	2570											
		dual			2780	2960	3150	3330	3520	3700	3890	4070	4260	4440	4630	4810	5000													
	AGILIS	single			1430	1520	1620	1710	1810	1900	2000	2090	2190	2280	2380	2470	2570													
		dual			2780	2960	3150	3330	3520	3700	3890	4070	4260	4440	4630	4810	5000													
7.50R16	AGILIS	single							1840	1940	2000	2090	2190	2280	2380	2470	2570	2675	2785	2890	3000									
		dual							3550	3740	3890	4070	4260	4440	4630	4810	5000	5200	5400	5600	5800									
	AGILIS HD	single							1840	1940	2000	2090	2190	2280	2380	2470	2570	2675	2785	2890	3000									
		dual							3550	3740	3890	4070	4260	4440	4630	4810	5000	5200	5400	5600	5800									
8.25R16	AGILIS	single							2160	2280	2400	2030	2130	2230	2320	2420	2520	2610	2710	2810	2900	3000								
		dual							4080	4310	4530	3930	4120	4300	4490	4680	4860	5050	5240	5430	5610	5800								
	AGILIS HD	single							2160	2280	2400	2030	2130	2230	2320	2420	2520	2610	2710	2810	2900	3000								
		dual							4080	4310	4530	3930	4120	4300	4490	4680	4860	5050	5240	5430	5610	5800								

- [15-16 INCHES](#)
- [17.5 INCHES](#)
- [19.5 INCHES](#)
- [20 INCHES](#)
- [20 AND 24 INCHES](#)
- [19.5 AND 22.5 INCHES WIDEBASE](#)
- [22.5 INCHES](#)
- [OFF-ROAD SIZES](#)
- [MICHELIN AGILIS 3 SIZES](#)
- [MICHELIN XCD2 SIZES](#)

Dimensional data for general indication only, for official data consult MICHELIN Technical Correspondent.

MICHELIN DIMENSIONAL DATA

17.5 INCHES

Dimension	Tread Pattern	Category	Type	PR (Ply Rating)	Load / Speed Index	Unique point (3)	Normal pressure for unique point (bar)	Original tread depth	Nominal load per axle (single) (kg)	Nominal pressure for load (single) (bar)	Nominal load per axle (dual) (kg)	Nominal pressure for load (dual) (bar)	Maximum section width in service (mm)	Maximum diameter in service (mm) (1)	Rolling circumference (mm)	Approved rim(s) ETRTO	Laden section width (mm) (2)	Free section width (mm) (2)	Diameter (mm) (2)	Static laden radius (mm) (2)	Rolling circumference (mm) (2)	Minimum dual spacing (mm) (2)	Recommended rim(s) by MICHELIN	Tube	Flap	Seal
215/70R17.5	XZE2	6	TL		118/116L			12.8	2640	6.00	5000	6.00	222	759	2315	6.00 - 6.75	229	209	759	355	2306	237	6.00			
245/70R17.5	X MULTI Z	6	TL		136/134M			12.5	4480	8.30	8480	8.30	258	803	2449	6.75 - 7.50	269	246	793	366	2417	209	6.75			
	XZE 2	6	TL		136/134M			13.5	4480	8.00	8480	8.00	258	803	2449	6.75 - 7.50	268	245	795	368	2424	277	6.75			
	X MULTI D	6	TL		136/134M			12.0	4480	8.30	8480	8.30	258	803	2449	6.75	268	246	795	368	2415	278	6.75			
	XDE 2	6	TL		136/134M			14.0	4480	8.00	8480	8.00	258	811	2474	6.75 - 7.50	268	245	797	368	2419	277	6.75			
205/75R17.5	XZE 2	6	TL		124/122M			12.5	3200	6.50	6000	6.50	212	765	2333	5.25-6.00-6.75	230	210	763	353	2310	238	6.00			
	XDE 2	6	TL		124/122M			14.0	3200	6.50	6000	6.50	212	773	2358	5.25-6.00-6.75	231	210	763	353	2312	238	6.00			
	X MULTI Z	6	TL	14	124/122M			11.5	3200	6.50	6000	6.50	212	765	2333	5.25-6.00-6.75	232	210	755	350	2304	238	6.00			
215/75R17.5	X MULTI Z	6	TL		126/124M			11.5	3400	6.90	6400	6.90	220	779	2376	6.00 - 6.75	237	217	770	357	2346	245	6.00			
	XZE 2	6	TL		126/124M			13.0	3400	6.50	6400	6.50	235	797	2431	6.00 - 6.75	238	217	774	357	2353	246	6.00			

• (1) ETRTO rating (standard value, the ETRTO standard rim may be different to the rim recommended by MICHELIN). • (2) MICHELIN rating, value measured on rim recommended by MICHELIN. • (3) Unique point: load capacity/authorized additional speed pair Load variations according to speed do not apply to the unique point.

See the next table for the recommended inflation pressure

- 15-16 INCHES
- 17.5 INCHES
- 19.5 INCHES
- 20 INCHES
- 20 AND 24 INCHES
- 19.5 AND 22.5 INCHES WIDEBASE
- 22.5 INCHES
- OFF-ROAD SIZES
- MICHELIN AGILIS 3 SIZES
- MICHELIN XCD2 SIZES

MICHELIN DIMENSIONAL DATA

17.5 INCHES

Table of inflation pressure (bar) in relation to maximum load per axle (kg)

Dimension	Tread pattern	Table of inflation pressure (bar) in relation to maximum load per axle (kg)																											
		psi	36	40	44	47	51	54	58	62	65	69	73	76	80	83	87	91	94	98	102	105	109	112	116	120	123	127	131
		bar	2.50	2.75	3.00	3.25	3.50	3.75	4.00	4.25	4.50	4.75	5.00	5.25	5.50	5.75	6.00	6.25	6.50	6.75	7.00	7.25	7.50	7.75	8.00	8.25	8.50	8.75	9.00
215/70R17.5	XZE2	single			1470	1560	1660	1760	1860	1960	2050	2150	2250	2350	2440	2540	2640												
		dual			2780	2960	3150	3330	3520	3700	3890	4070	4260	4440	4630	4810	5000												
245/70R17.5	X MULTI Z	single											2850	2970	3090	3220	3340	3470	3590	3710	3840	3960	4080	4210	4330	4460			
		dual											5390	5620	5860	6090	6320	6560	6790	7030	7260	7500	7730	7960	8200	8430			
	XZE 2	single											2940	3070	3200	3330	3460	3580	3710	3840	3970	4100	4220	4350	4480				
		dual											5570	5810	6060	6300	6540	6780	7030	7270	7510	7750	8000	8240	8480				
	X MULTI D	single											2850	2970	3090	3220	3340	3470	3590	3710	3840	3960	4080	4210	4330	4460			
		dual											5390	5620	5860	6090	6320	6560	6790	7030	7260	7500	7730	7960	8200	8430			
	XDE 2	single											2940	3070	3200	3330	3460	3580	3710	3840	3970	4100	4220	4350	4480				
		dual											5570	5810	6060	6300	6540	6780	7030	7270	7510	7750	8000	8240	8480				
205/75R17.5	XZE 2	single				1880	1990	2100	2210	2320	2430	2540	2650	2760	2870	2980	3090	3200											
		dual				3520	3720	3930	4140	4340	4550	4760	4970	5170	5380	5590	5790	6000											
	XDE 2	single				1880	1990	2100	2210	2320	2430	2540	2650	2760	2870	2980	3090	3200											
		dual				3520	3720	3930	4140	4340	4550	4760	4970	5170	5380	5590	5790	6000											
	X MULTI Z	single				1880	1990	2100	2210	2320	2430	2540	2650	2760	2870	2980	3090	3200											
		dual				3520	3720	3930	4140	4340	4550	4760	4970	5170	5380	5590	5790	6000											
215/75R17.5	X MULTI Z	single						2110	2220	2330	2440	2560	2670	2780	2890	3000	3110	3220	3330										
		dual						3970	4180	4390	4600	4810	5020	5230	5440	5650	5860	6070	6270										
	XZE 2	single				1990	2110	2230	2340	2460	2580	2700	2810	2930	3050	3170	3280	3400											
		dual				3750	3970	4190	4410	4630	4860	5080	5300	5520	5740	5960	6180	6400											

- 15-16 INCHES
- 17.5 INCHES
- 19.5 INCHES
- 20 INCHES
- 20 AND 24 INCHES
- 19.5 AND 22.5 INCHES WIDEBASE
- 22.5 INCHES
- OFF-ROAD SIZES
- MICHELIN AGILIS 3 SIZES
- MICHELIN XCD2 SIZES

Dimensional data for general indication only, for official data consult MICHELIN Technical Correspondent.

MICHELIN DIMENSIONAL DATA

17.5 INCHES

Dimension	Tread Pattern	Category	Type	PR (Ply Rating)	Load / Speed Index	Unique point (3)	Normal pressure for unique point (bar)	Original tread depth	Nominal load per axle (single) (kg)	Nominal pressure for load (single) (bar)	Nominal load per axle (dual) (kg)	Nominal pressure for load (dual) (bar)	Maximum section width in service (mm)	Maximum diameter in service (mm) (1)	Rolling circumference (mm)	Approved rim(s) ETRTO	Laden section width (mm) (2)	Free section width (mm) (2)	Diameter (mm) (2)	Static laden radius (mm) (2)	Rolling circumference (mm) (2)	Minimum dual spacing (mm) (2)	Recommended rim(s) by MICHELIN	Tube	Flap	Seal
215/75R17.5	X MULTI D	6	TL		126/124M			13.0	3400	6.90	6400	6.90	220	779	2376	6.00 - 6.75	236	216	775	359	2350	245	6.00			
	XDE 2	6	TL		126/124M			15.0	3400	6.50	6400	6.50	235	797	2431	6.00 - 6.75	238	216	778	360	2370	245	6.00			
	XTE2+	2	TL		135/133J			12.2	4360	8.50	8240	8.50	220	779		6.00 - 6.75	236	215	777	359	2370	243	6.00			
	X MULTI T2	2	TL	18	136/134J			12.2	4480	9.00	8480	9.00	220	779		6.00 - 6.75	226	208	766	354	2353		6.00			
225/75R17.5	X MULTI Z	6	TL		129/127M			11.5	3700	7.20	7000	7.20	235	797	2431	6.00 - 6.75	255	233	787	366	2407	264	6.75			
	XZE 2	6	TL		129/127M			13.0	3700	7.00	7000	7.00	235	797	2431	6.00 - 6.75	255	233	792	367	2414	264	6.75			
	X MULTI D	6	TL		129/127M			12.5	3700	7.20	7000	7.20	235	797	2431	6.00 - 6.75	256	234	790	367	2400	264	6.75			
	XDE 2	6	TL		129/127M			15.0	3700	7.00	7000	7.00	235	803	2449	6.00 - 6.75	255	232	798	369	2415	263	6.75			
235/75R17.5	X MULTI Z	6	TL	16	132/130M			12.5	4000	7.60	7600	7.60	242	811	2474	6.75 - 7.50	243	241	799	371	2439	272	6.75			
	XZE 2	6	TL		132/130M			13.0	4000	7.25	7600	7.25	242	811	2474	6.75 - 7.50	261	239	805	373	2451	271	6.75			
	X MULTI D	6	TL	16	132/130M			12.5	4000	7.60	6800	7.60	242	811	2474	6.75 - 7.50	262	240	501	370	2433	272	6.75			
	XDE 2	6	TL		132/130M			15.0	4000	7.25	7600	7.25	242	811	2474	6.75 - 7.50	262	239	807	373	2447	271	6.75			
	XTE2+	2	TL		143/141J			12.3	5450	8.50	10300	8.50	242	811		6.75 - 7.50	265	241	796	364	2410	273	6.75			
	X MULTI T2	2	TL	18	143/141J	145/145F	9.00	12.6	5450	9.00	10300	9.00	242	811		6.75 - 7.50	264	240	797	365	2445		6.75			

• (1) ETRTO rating (standard value, the ETRTO standard rim may be different to the rim recommended by MICHELIN). • (2) MICHELIN rating, value measured on rim recommended by MICHELIN. • (3) Unique point: load capacity/authorized additional speed pair Load variations according to speed do not apply to the unique point.

See the next table for the recommended inflation pressure

Dimensional data for general indication only, for official data consult MICHELIN Technical Correspondent.

- 15-16 INCHES
- 17.5 INCHES
- 19.5 INCHES
- 20 INCHES
- 20 AND 24 INCHES
- 19.5 AND 22.5 INCHES WIDEBASE
- 22.5 INCHES
- OFF-ROAD SIZES
- MICHELIN AGILIS 3 SIZES
- MICHELIN XCD2 SIZES

MICHELIN DIMENSIONAL DATA

17.5 INCHES

Table of inflation pressure (bar) in relation to maximum load per axle (kg)

Dimension	Tread pattern	Table of inflation pressure (bar) in relation to maximum load per axle (kg)																												
		psi	36	40	44	47	51	54	58	62	65	69	73	76	80	83	87	91	94	98	102	105	109	112	116	120	123	127	131	
		bar	2.50	2.75	3.00	3.25	3.50	3.75	4.00	4.25	4.50	4.75	5.00	5.25	5.50	5.75	6.00	6.25	6.50	6.75	7.00	7.25	7.50	7.75	8.00	8.25	8.50	8.75	9.00	
215/75R17.5	X MULTI D	single							2110	2220	2330	2440	2560	2670	2780	2890	3000	3110	3220	3330										
		dual							3970	4180	4390	4600	4810	5020	5230	5440	5650	5860	6070	6270										
	XDE 2	single					1990	2110	2230	2340	2460	2580	2700	2810	2930	3050	3170	3280	3400											
		dual					3750	3970	4190	4410	4630	4860	5080	5300	5520	5740	5960	6180	6400											
	XTE2+	single													2950	3060	3180	3300	3420	3540	3650	3770	3890	4010	4120	4240				
		dual													5570	5790	6010	6240	6460	6680	6900	7130	7350	7570	7790	8020				
	X MULTI T2	single													2860	2980	3090	3210	3320	3440	3550	3660	3780	3890	4010	4120	4240	4360	4480	
		dual													5460	5680	5890	6110	6330	6540	6760	6980	7190	7410	7630	7840	8080	8280	8480	
225/75R17.5	X MULTI Z	single							2210	2330	2440	2560	2680	2790	2910	3030	3140	3260	3370	3490	3610									
		dual							4180	4400	4620	4840	5060	5280	5500	5720	5940	6160	6380	6600	6820									
	XZE 2	single							2270	2390	2510	2630	2750	2860	2980	3100	3220	3340	3460	3580	3700									
		dual							4290	4520	4740	4970	5190	5420	5650	5870	6100	6320	6550	6770	7000									
	X MULTI D	single							2210	2330	2440	2560	2680	2790	2910	3030	3140	3260	3370	3490	3610									
		dual							4180	4400	4620	4840	5060	5280	5500	5720	5940	6160	6380	6600	6820									
	XDE 2	single							2270	2390	2510	2630	2750	2860	2980	3100	3220	3340	3460	3580	3700									
		dual							4290	4520	4740	4970	5190	5420	5650	5870	6100	6320	6550	6770	7000									
235/75R17.5	X MULTI Z	single											2750	2870	2990	3110	3230	3350	3470	3590	3710	3830	3950							
		dual											5230	5460	5690	5920	6140	6370	6600	6830	7050	7280	7510							
	XZE 2	single								2500	2630	2750	2880	3000	3130	3250	3380	3500	3630	3750	3880	4000								
		dual								4750	4990	5230	5460	5700	5940	6180	6410	6650	6890	7130	7360	7600								
	X MULTI D	single											2750	2870	2990	3110	3230	3350	3470	3590	3710	3830	3950							
		dual											5230	5460	5690	5920	6140	6370	6600	6830	7050	7280	7510							
	XDE 2	single								2500	2630	2750	2880	3000	3130	3250	3380	3500	3630	3750	3880	4000								
		dual								4750	4990	5230	5460	5700	5940	6180	6410	6650	6890	7130	7360	7600								
	XTE2+	single													3680	3830	3980	4120	4270	4420	4570	4710	4860	5010	5160	5300				
		dual													6960	7240	7520	7790	8070	8350	8630	8910	9190	9460	9740	10020				
	X MULTI T2	single														3500	3630	3770	3910	4050	4190	4330	4470	4610	4750	4880	5020	5160	5300	5450
		dual														6600	6850	7110	7380	7660	7940	8200	8450	8700	8950	9220	9500	9770	10050	10300

- 15-16 INCHES
- 17.5 INCHES
- 19.5 INCHES
- 20 INCHES
- 20 AND 24 INCHES
- 19.5 AND 22.5 INCHES WIDEBASE
- 22.5 INCHES
- OFF-ROAD SIZES
- MICHELIN AGILIS 3 SIZES
- MICHELIN XCD2 SIZES

Dimensional data for general indication only, for official data consult MICHELIN Technical Correspondent.

MICHELIN DIMENSIONAL DATA

17.5 INCHES

Dimension	Tread Pattern	Category	Type	PR (Ply Rating)	Load / Speed Index	Unique point (3)	Normal pressure for unique point (bar)	Original tread depth	Nominal load per axle (single) (kg)	Nominal pressure for load (single) (bar)	Nominal load per axle (dual) (kg)	Nominal pressure for load (dual) (bar)	Maximum section width in service (mm)	Maximum diameter in service (mm) (1)	Rolling circumference (mm)	Approved rim(s) ETRTO	Laden section width (mm) (2)	Free section width (mm) (2)	Diameter (mm) (2)	Static laden radius (mm) (2)	Rolling circumference (mm) (2)	Minimum dual spacing (mm) (2)	Recommended rim(s) by MICHELIN	Tube	Flap	Seal
225/80R17.5	XZN+ MIX ENERGY	6	TL	14	123/122L			11.8	3100	6.00	6000	6.00	228	810	2471	6.00 - 6.75	248	225	811	378	2465	254	6.75			
	XZN MIX ENERGY	6	TL	14	123/122L			11.8	3100	6.00	6000	6.00	228	810	2471	6.00 - 6.75	248	225	811	378	2465	254	6.75			
	XJE4 MIX ENERGY	6	TL		123/122L			13.3	3100	6.00	6000	6.00	228	810	2471	6.00 - 6.75	248	225	810	378	2467	255	6.75			
	XJS WINTER GRIP+	6	TL	14	123/122L			14.5	3100	6.00	6000	6.00	228	810	2471	6.00 - 6.75	250	228	810	378	2480	258	6.75			
	XDW ICE GRIP	6	TL	14	123/122L			14.5	3100	6.00	6000	6.00	228	810	2471	6.00 - 6.75	251	228	810	378	2480	258	6.75			
8.5R17.5	XZA	6	TL		121/120L			12.5	2900	6.25	5600	6.25	224	817	2492	5.25-6.00-6.75	221	200	802	372	2447	227	5.25			
	XZT	6	TL		121/120L			14.7	2900	6.25	5600	6.25	224	817	2492	5.25-6.00-6.75	222	200	806	374	2459	227	5.25			
	XZY	6	TL		121/120L			13.4	2900	6.25	5600	6.25	224	817	2492	5.25-6.00-6.75	220	200	806	374	2460	227	5.25			

• (1) ETRTO rating (standard value, the ETRTO standard rim may be different to the rim recommended by MICHELIN). • (2) MICHELIN rating, value measured on rim recommended by MICHELIN. • (3) Unique point: load capacity/authorized additional speed pair Load variations according to speed do not apply to the unique point.

See the next table for the recommended inflation pressure

- 15-16 INCHES
- 17.5 INCHES
- 19.5 INCHES
- 20 INCHES
- 20 AND 24 INCHES
- 19.5 AND 22.5 INCHES WIDEBASE
- 22.5 INCHES
- OFF-ROAD SIZES
- MICHELIN AGILIS 3 SIZES
- MICHELIN XCD2 SIZES

MICHELIN DIMENSIONAL DATA

17.5 INCHES

Table of inflation pressure (bar) in relation to maximum load per axle (kg)

Dimension	Tread pattern	Table of inflation pressure (bar) in relation to maximum load per axle (kg)																												
		psi	36	40	44	47	51	54	58	62	65	69	73	76	80	83	87	91	94	98	102	105	109	112	116	120	123	127	131	
		bar	2.50	2.75	3.00	3.25	3.50	3.75	4.00	4.25	4.50	4.75	5.00	5.25	5.50	5.75	6.00	6.25	6.50	6.75	7.00	7.25	7.50	7.75	8.00	8.25	8.50	8.75	9.00	
225/80R17.5	XZN+ MIX ENERGY	single			1720	1840	1950	2070	2180	2300	2410	2530	2640	2760	2870	2990	3100													
		dual			3330	3560	3780	4000	4220	4440	4670	4890	5110	5330	5560	5780	6000													
	XZN MIX ENERGY	single			1720	1840	1950	2070	2180	2300	2410	2530	2640	2760	2870	2990	3100													
		dual			3330	3560	3780	4000	4220	4440	4670	4890	5110	5330	5560	5780	6000													
	XJE4 MIX ENERGY	single			1720	1840	1950	2070	2180	2300	2410	2530	2640	2760	2870	2990	3100													
		dual			3330	3560	3780	4000	4220	4440	4670	4890	5110	5330	5560	5780	6000													
	XJS WINTER GRIP+	single			1720	1840	1950	2070	2180	2300	2410	2530	2640	2760	2870	2990	3100													
		dual			3330	3560	3780	4000	4220	4440	4670	4890	5110	5330	5560	5780	6000													
	XDW ICE GRIP	single			1720	1840	1950	2070	2180	2300	2410	2530	2640	2760	2870	2990	3100													
		dual			3330	3560	3780	4000	4220	4440	4670	4890	5110	5330	5560	5780	6000													
8.5R17.5	XZA	single			1660	1760	1860	1970	2070	2180	2280	2380	2490	2590	2690	2800	2900													
		dual			3200	3400	3600	3800	4000	4200	4400	4600	4800	5000	5200	5400	5600													
	XZT	single			1660	1760	1860	1970	2070	2180	2280	2380	2490	2590	2690	2800	2900													
		dual			3200	3400	3600	3800	4000	4200	4400	4600	4800	5000	5200	5400	5600													
	XZY	single			1660	1760	1860	1970	2070	2180	2280	2380	2490	2590	2690	2800	2900													
		dual			3200	3400	3600	3800	4000	4200	4400	4600	4800	5000	5200	5400	5600													

- 15-16 INCHES
- 17.5 INCHES
- 19.5 INCHES
- 20 INCHES
- 20 AND 24 INCHES
- 19.5 AND 22.5 INCHES WIDEBASE
- 22.5 INCHES
- OFF-ROAD SIZES
- MICHELIN AGILIS 3 SIZES
- MICHELIN XCD2 SIZES

Dimensional data for general indication only, for official data consult MICHELIN Technical Correspondent.

MICHELIN DIMENSIONAL DATA

17.5 INCHES

Dimension	Tread Pattern	Category	Type	PR (Ply Rating)	Load / Speed Index	Unique point (3)	Normal pressure for unique point (bar)	Original tread depth	Nominal load per axle (single) (kg)	Nominal pressure for load (single) (bar)	Nominal load per axle (dual) (kg)	Nominal pressure for load (dual) (bar)	Maximum section width in service (mm)	Maximum diameter in service (mm) (1)	Rolling circumference (mm)	Approved rim(s) ETRTO	Laden section width (mm) (2)	Free section width (mm) (2)	Diameter (mm) (2)	Static laden radius (mm) (2)	Rolling circumference (mm) (2)	Minimum dual spacing (mm) (2)	Recommended rim(s) by MICHELIN	Tube	Flap	Seal
9.5R17.5	X MULTI Z	6	TL		129/127L	143J	8.50	11.6	3700	7.50	7000	7.50	250	857	2614	6.00 - 6.75	257	237	843	393	2581	270	6.75			
	XZA+	6	TL		129/127L	143J	8.50	12.1	3700	7.00	7000	7.00	250	857	2614	6.00 - 6.75	258	236	843	392	2580	267	6.00			
	XZA	6	TL	14	129/127L			11.6	3700	7.00	7000	7.00	250	857	2614	6.00 - 6.75	246	222	843	390	2568	252	6.00			
	XZT	6	TL		129/127L			16.0	3700	7.00	7000	7.00	250	857	2614	6.00 - 6.75	253	231	844	391	2572	262	6.00			
	XZY	6	TL		129/127L			14.0	3700	7.00	7000	7.00	250	857	2614	6.00 - 6.75	250	228	840	388	2559	258	6.00			
	XTE2	2	TL	18	143/141J			13	5450	8.50	10300	8.50	250	857		6.00 - 6.75	257	230	846	386	2560	260	6.75			
10R17.5	XZA	6	TL		134/132L			12.5	4240	7.50	8000	7.50	264	875	2669	6.75 - 7.50	266	241	861	397	2620	273	6.75			
225/90R17.5	XJE4 MIX ENERGY	6	TL		127/125L			13.5	3500	6.50	6600	6.50	237	867	2644	6.00 - 6.75	255	230	845	393	2573	260	6.75			
	XDW ICE GRIP	6	TL	14	127/125L			14.5	3500	6.50	6600	6.50	237	867	2644	6.75 - 6.00	257	232	849	395	2590	263	6.75			

• (1) ETRTO rating (standard value, the ETRTO standard rim may be different to the rim recommended by MICHELIN). • (2) MICHELIN rating, value measured on rim recommended by MICHELIN. • (3) Unique point: load capacity/authorized additional speed pair Load variations according to speed do not apply to the unique point.

See the next table for the recommended inflation pressure

- 15-16 INCHES
- 17.5 INCHES
- 19.5 INCHES
- 20 INCHES
- 20 AND 24 INCHES
- 19.5 AND 22.5 INCHES WIDEBASE
- 22.5 INCHES
- OFF-ROAD SIZES
- MICHELIN AGILIS 3 SIZES
- MICHELIN XCD2 SIZES

MICHELIN DIMENSIONAL DATA

17.5 INCHES

Table of inflation pressure (bar) in relation to maximum load per axle (kg)

Dimension	Tread pattern	Table of inflation pressure (bar) in relation to maximum load per axle (kg)																												
		psi	36	40	44	47	51	54	58	62	65	69	73	76	80	83	87	91	94	98	102	105	109	112	116	120	123	127	131	
		bar	2.50	2.75	3.00	3.25	3.50	3.75	4.00	4.25	4.50	4.75	5.00	5.25	5.50	5.75	6.00	6.25	6.50	6.75	7.00	7.25	7.50	7.75	8.00	8.25	8.50	8.75	9.00	
9.5R17.5	X MULTI Z	single								2350	2470	2580	2690	2800	2920	3030	3140	3250	3360	3480	3590	3700								
		dual								4450	4670	4880	5090	5300	5520	5730	5940	6150	6360	6580	6790	7000								
	XZA+	single							2270	2390	2510	2630	2750	2860	2980	3100	3220	3340	3460	3580	3700									
		dual							4290	4520	4740	4970	5190	5420	5650	5870	6100	6320	6550	6770	7000									
	XZA	single							2270	2390	2510	2630	2750	2860	2980	3100	3220	3340	3460	3580	3700									
		dual							4290	4520	4740	4970	5190	5420	5650	5870	6100	6320	6550	6770	7000									
	XZT	single							2270	2390	2510	2630	2750	2860	2980	3100	3220	3340	3460	3580	3700									
		dual							4290	4520	4740	4970	5190	5420	5650	5870	6100	6320	6550	6770	7000									
	XZY	single							2270	2390	2510	2630	2750	2860	2980	3100	3220	3340	3460	3580	3700									
		dual							4290	4520	4740	4970	5190	5420	5650	5870	6100	6320	6550	6770	7000									
	XTE2	single														3680	3830	3980	4120	4270	4420	4570	4710	4860	5010	5160	5300			
		dual													6960	7240	7520	7790	8070	8350	8630	8910	9190	9460	9740	10020				
10R17.5	XZA	single								2700	2830	2960	3080	3210	3340	3470	3600	3730	3850	3980	4110	4240								
		dual								5090	5330	5580	5820	6060	6300	6550	6790	7030	7270	7520	7760	8000								
225/90R17.5	XJE4 MIX ENERGY	single					2050	2170	2290	2410	2530	2660	2780	2900	3020	3140	3260	3380	3500											
		dual					3870	4100	4320	4550	4780	5010	5230	5460	5690	5920	6140	6370	6600											
	XDW ICE GRIP	single					2050	2170	2290	2410	2530	2660	2780	2900	3020	3140	3260	3380	3500											
		dual					3870	4100	4320	4550	4780	5010	5230	5460	5690	5920	6140	6370	6600											

- 15-16 INCHES
- 17.5 INCHES
- 19.5 INCHES
- 20 INCHES
- 20 AND 24 INCHES
- 19.5 AND 22.5 INCHES WIDEBASE
- 22.5 INCHES
- OFF-ROAD SIZES
- MICHELIN AGILIS 3 SIZES
- MICHELIN XCD2 SIZES

Dimensional data for general indication only, for official data consult MICHELIN Technical Correspondent.

MICHELIN DIMENSIONAL DATA

19.5 INCHES

Dimension	Tread Pattern	Category	Type	PR (Ply Rating)	Load / Speed Index	Unique point (3)	Normal pressure for unique point (bar)	Original tread depth	Nominal load per axle (single) (kg)	Nominal pressure for load (single) (bar)	Nominal load per axle (dual) (kg)	Nominal pressure for load (dual) (bar)	Maximum section width in service (mm)	Maximum diameter in service (mm) (1)	Rolling circumference (mm)	Approved rim(s) ETRTO	Laden section width (mm) (2)	Free section width (mm) (2)	Diameter (mm) (2)	Static laden radius (mm) (2)	Rolling circumference (mm) (2)	Minimum dual spacing (mm) (2)	Recommended rim(s) by MICHELIN	Tube	Flap	Seal
225/70R19.5	XZE	6	TL		125/123L			13.3								6.00 - 6.75	240	227	819	378	2490	246	6.00			
245/70R19.5	X MULTI Z	6	TL	16	136/134M			12.0	4480	7.90	8480	7.90	258	853	2602	6.75 - 7.50	246	243	845	393	2583	275	6.75			
	XJE4 MIX ENERGY	6	TL		136/134L	136/134J	7.75	13.5	4480	7.75	8480	7.75	258	853	2602	6.75 - 7.50	265	242	851	395	2593	274	6.75			
	XZN+ MIX ENERGY	6	TL		136/134L			12.3	4480	7.75	8480	7.75	248	839	2559	6.75 - 7.50	265	242	848	395	2589	270	6.75			
	XZN MIX ENERGY	6	TL		136/134L			12.3	4480	7.75	8480	7.75	248	839	2559	6.75 - 7.50	265	242	848	395	2589	270	6.75			
	XZE2+	6	TL		136/134M	136/135J	7.75	13.0	4480	7.75	8480	7.75	258	853	2602	6.75 - 7.50	267	244	849	394	2590	276	6.75			
	X MULTI D	6	TL	16	136/134M	136/135J	7.90	12.0	4480	7.90	8480	7.90	258	853	2602	6.75 - 7.50	263	241	847	394	2580	273	6.75			
	XDE2+	6	TL		136/134M	136/135J	7.75	15.0	4480	7.75	8480	7.75	258	853	2602	6.75 - 7.50	267	244	853	396	2600	276	6.75			

• (1) ETRTO rating (standard value, the ETRTO standard rim may be different to the rim recommended by MICHELIN). • (2) MICHELIN rating, value measured on rim recommended by MICHELIN. • (3) Unique point: load capacity/authorized additional speed pair Load variations according to speed do not apply to the unique point.

See the next table for the recommended inflation pressure

- 15-16 INCHES
- 17.5 INCHES
- 19.5 INCHES
- 20 INCHES
- 20 AND 24 INCHES
- 19.5 AND 22.5 INCHES WIDEBASE
- 22.5 INCHES
- OFF-ROAD SIZES
- MICHELIN AGILIS 3 SIZES
- MICHELIN XCD2 SIZES

MICHELIN DIMENSIONAL DATA

19.5 INCHES

Table of inflation pressure (bar) in relation to maximum load per axle (kg)

Dimension	Tread pattern	Table of inflation pressure (bar) in relation to maximum load per axle (kg)																												
		psi	36	40	44	47	51	54	58	62	65	69	73	76	80	83	87	91	94	98	102	105	109	112	116	120	123	127	131	
		bar	2.50	2.75	3.00	3.25	3.50	3.75	4.00	4.25	4.50	4.75	5.00	5.25	5.50	5.75	6.00	6.25	6.50	6.75	7.00	7.25	7.50	7.75	8.00	8.25	8.50	8.75	9.00	
225/70R19.5	XZE	single									2500	2620	2760	2830	2900	2950	3000	3140	3300											
		dual									4720	4920	5200	5300	5400	5520	5640	5880	6200											
245/70R19.5	X MULTI Z	single											2980	3110	3240	3370	3500	3630	3750	3880	4010	4140	4270	4400						
		dual											5640	5880	6130	6370	6620	6860	7110	7350	7600	7840	8090	8330						
	XJE4 MIX ENERGY	single									2900	3030	3160	3290	3430	3560	3690	3820	3950	4080	4220	4350	4480							
		dual									5490	5740	5990	6240	6480	6730	6980	7230	7480	7730	7980	8230	8480							
	XZN+ MIX ENERGY	single									2900	3030	3160	3290	3430	3560	3690	3820	3950	4080	4220	4350	4480							
		dual									5490	5740	5990	6240	6480	6730	6980	7230	7480	7730	7980	8230	8480							
	XZN MIX ENERGY	single									2900	3030	3160	3290	3430	3560	3690	3820	3950	4080	4220	4350	4480							
		dual									5490	5740	5990	6240	6480	6730	6980	7230	7480	7730	7980	8230	8480							
	XZE2+	single									2900	3030	3160	3290	3430	3560	3690	3820	3950	4080	4220	4350	4480							
		dual									5490	5740	5990	6240	6480	6730	6980	7230	7480	7730	7980	8230	8480							
	X MULTI D	single											2980	3110	3240	3370	3500	3630	3750	3880	4010	4140	4270	4400						
		dual											5640	5880	6130	6370	6620	6860	7110	7350	7600	7840	8090	8330						
	XDE2+	single									2900	3030	3160	3290	3430	3560	3690	3820	3950	4080	4220	4350	4480							
		dual									5490	5740	5990	6240	6480	6730	6980	7230	7480	7730	7980	8230	8480							

- 15-16 INCHES
- 17.5 INCHES
- 19.5 INCHES
- 20 INCHES
- 20 AND 24 INCHES
- 19.5 AND 22.5 INCHES WIDEBASE
- 22.5 INCHES
- OFF-ROAD SIZES
- MICHELIN AGILIS 3 SIZES
- MICHELIN XCD2 SIZES

Dimensional data for general indication only, for official data consult MICHELIN Technical Correspondent.

MICHELIN DIMENSIONAL DATA

19.5 INCHES

Dimension	Tread Pattern	Category	Type	PR (Ply Rating)	Load / Speed Index	Unique point (3)	Normal pressure for unique point (bar)	Original tread depth	Nominal load per axle (single) (kg)	Nominal pressure for load (single) (bar)	Nominal load per axle (dual) (kg)	Nominal pressure for load (dual) (bar)	Maximum section width in service (mm)	Maximum diameter in service (mm) (1)	Rolling circumference (mm)	Approved rim(s) ETRTO	Laden section width (mm) (2)	Free section width (mm) (2)	Diameter (mm) (2)	Static laden radius (mm) (2)	Rolling circumference (mm) (2)	Minimum dual spacing (mm) (2)	Recommended rim(s) by MICHELIN	Tube	Flap	Seal
245/70R19.5	XJS WINTER GRIP+	6	TL		136/134L			16.5	4480	7.75	8480	7.75	258	853	2602	6.75 - 7.50	269	247	855	397	2610	280	6.75			
	XDW ICE GRIP	6	TL		136/134L			16.5	4480	7.75	8480	7.75	258	853	2602	6.75 - 7.50	268	246	857	397	2610	278	6.75			
265/70R19.5	X MULTI Z	6	TL	14	140/138M			12.5	5000	7.60	9440	7.60	272	881	2687	6.75 - 7.50 - 8.25	287	259	864	401	2642	293	7.50			
	XZN+ MIX ENERGY	6	TL		140/138L			13.0	5000	7.75	9440	7.75	272	881	2687	6.75 - 7.50 - 8.25	296	262	870	393	2615	300	7.50			
	XZN MIX ENERGY	6	TL		140/138L			13.0	5000	7.75	9440	7.75	272	881	2687	6.75 - 7.50 - 8.25	296	262	870	393	2615	300	7.50			
	XZE2+	6	TL		140/138M			13.6	5000	7.75	9440	7.75	272	881	2687	6.75 - 7.50 - 8.25	287	263	870	402	2650	297	7.50			
	XJW4+	6	TL		140/138L			15.0	5000	7.75	9440	7.75	272	881	2687	6.75 - 7.50 - 8.25	283	263	872	405	2660	298	7.50			
	X MULTI D	6	TL		140/138M			12.5	5000	7.60	9440	7.60	272	881	2687	6.75 - 7.50 - 8.25	285	262	868	402	2638	296	7.50			
	XDE2+	6	TL		140/138M			16.0	5000	7.75	9440	7.75	272	881	2687	6.75 - 7.50 - 8.25	262	262	875	404	2660	297	7.50			
	XDW ICE GRIP	6	TL		140/138L			16.0	5000	7.75	9440	7.75	272	881	2687	6.75 - 7.50 - 8.25	288	264	875	405	2670	299	7.50			
	XTE2	2	TL		143/141J			14.0	5450	8.50	10300	8.60	272	881		6.75-7.50-8.25	286	265	870	403	2650	300	7.50			

• (1) ETRTO rating (standard value, the ETRTO standard rim may be different to the rim recommended by MICHELIN). • (2) MICHELIN rating, value measured on rim recommended by MICHELIN. • (3) Unique point: load capacity/authorized additional speed pair Load variations according to speed do not apply to the unique point.

See the next table for the recommended inflation pressure

Dimensional data for general indication only, for official data consult MICHELIN Technical Correspondent.

- 15-16 INCHES
- 17.5 INCHES
- 19.5 INCHES
- 20 INCHES
- 20 AND 24 INCHES
- 19.5 AND 22.5 INCHES WIDEBASE
- 22.5 INCHES
- OFF-ROAD SIZES
- MICHELIN AGILIS 3 SIZES
- MICHELIN XCD2 SIZES

MICHELIN DIMENSIONAL DATA

19.5 INCHES

Table of inflation pressure (bar) in relation to maximum load per axle (kg)

Dimension	Tread pattern	psi	36	40	44	47	51	54	58	62	65	69	73	76	80	83	87	91	94	98	102	105	109	112	116	120	123	127	131	
		bar	2.50	2.75	3.00	3.25	3.50	3.75	4.00	4.25	4.50	4.75	5.00	5.25	5.50	5.75	6.00	6.25	6.50	6.75	7.00	7.25	7.50	7.75	8.00	8.25	8.50	8.75	9.00	
245/70R19.5	XJS WINTER GRIP+	single										2900	3030	3160	3290	3430	3560	3690	3820	3950	4080	4220	4350	4480						
		dual											5490	5740	5990	6240	6480	6730	6980	7230	7480	7730	7980	8230	8480					
	XDW ICE GRIP	single											2900	3030	3160	3290	3430	3560	3690	3820	3950	4080	4220	4350	4480					
		dual											5490	5740	5990	6240	6480	6730	6980	7230	7480	7730	7980	8230	8480					
265/70R19.5	X MULTI Z	single											3440	3590	3740	3890	4040	4190	4340	4490	4640	4790	4940							
		dual											6500	6780	7070	7350	7630	7910	8200	8480	8760	9040	9330							
	XZN+ MIX ENERGY	single											3240	3380	3530	3680	3820	3970	4120	4260	4410	4560	4710	4850	5000					
		dual											6110	6390	6660	6940	7220	7500	7770	8050	8330	8610	8880	9160	9440					
	XZN MIX ENERGY	single											3240	3380	3530	3680	3820	3970	4120	4260	4410	4560	4710	4850	5000					
		dual											6110	6390	6660	6940	7220	7500	7770	8050	8330	8610	8880	9160	9440					
	XZE2+	single											3230	3380	3530	3670	3820	3970	4110	4260	4410	4550	4700	4850	5000					
		dual											6110	6390	6660	6940	7220	7500	7770	8050	8330	8610	8880	9160	9440					
	XJW4+	single											3230	3380	3530	3670	3820	3970	4110	4260	4410	4550	4700	4850	5000					
		dual											6110	6390	6660	6940	7220	7500	7770	8050	8330	8610	8880	9160	9440					
	X MULTI D	single												3440	3590	3740	3890	4040	4190	4340	4490	4640	4790	4940						
		dual											6500	6780	7070	7350	7630	7910	8200	8480	8760	9040	9330							
	XDE2+	single											3230	3380	3530	3670	3820	3970	4110	4260	4410	4550	4700	4850	5000					
		dual											6110	6390	6660	6940	7220	7500	7770	8050	8330	8610	8880	9160	9440					
	XDW ICE GRIP	single											3230	3380	3530	3670	3820	3970	4110	4260	4410	4550	4700	4850	5000					
		dual											6110	6390	6660	6940	7220	7500	7770	8050	8330	8610	8880	9160	9440					
XTE2	single														3680	3830	3980	4120	4270	4420	4570	4710	4860	5010	5160	5300				
	dual														6960	7240	7520	7790	8070	8350	8630	8910	9190	9460	9740	10020				

- 15-16 INCHES
- 17.5 INCHES
- 19.5 INCHES
- 20 INCHES
- 20 AND 24 INCHES
- 19.5 AND 22.5 INCHES WIDEBASE
- 22.5 INCHES
- OFF-ROAD SIZES
- MICHELIN AGILIS 3 SIZES
- MICHELIN XCD2 SIZES

Dimensional data for general indication only, for official data consult MICHELIN Technical Correspondent.

MICHELIN DIMENSIONAL DATA

19.5 INCHES

Dimension	Tread Pattern	Category	Type	PR (Ply Rating)	Load / Speed Index	Unique point (3)	Normal pressure for unique point (bar)	Original tread depth	Nominal load per axle (single) (kg)	Nominal pressure for load (single) (bar)	Nominal load per axle (dual) (kg)	Nominal pressure for load (dual) (bar)	Maximum section width in service (mm)	Maximum diameter in service (mm) (1)	Rolling circumference (mm)	Approved rim(s) ETRTO	Laden section width (mm) (2)	Free section width (mm) (2)	Diameter (mm) (2)	Static laden radius (mm) (2)	Rolling circumference (mm) (2)	Minimum dual spacing (mm) (2)	Recommended rim(s) by MICHELIN	Tube	Flap	Seal
285/70R19.5	X MULTI Z	6	TL		146/144L	145/143M	8.30	12.5	6000	8.30	11200	8.30	294	911	2779	7.50 - 8.25 - 9.00	298	273	893	411	2721	309	7.50			
	XZE2+	6	TL		144/142M	145/143L	8.00	13.9	5600	8.00	10600	8.00	294	911	2779	7.50 - 8.25 - 9.00	301	275	895	412	2720	311	7.50			
	X MULTI D	6	TL		146/144L	145/143M	8.30	13.5	6000	8.30	11200	8.30	294	911	2779	7.50 - 8.25 - 9.00	276	273	897	412	2720	309	7.50			
	XDE2+	6	TL		144/142M	145/143L	8.00	16.5	5600	8.00	10600	8.00	294	911	2779	7.50 - 8.25 - 9.00	300	274	899	414	2740	310	7.50			
305/70R19.5	XZE2+	6	TL		147/145M	148/146L	8.00	14.9	6150	8.00	11600	8.00	309	941	2870	8.25 - 9.00	327	301	924	424	2800	341	8.25			
	XDE2+	6	TL		147/145M	148/146L	8.00	17.5	6150	8.00	11600	8.00	309	949	2894	8.25 - 9.00	327	301	931	428	2830	341	8.25			

• (1) ETRTO rating (standard value, the ETRTO standard rim may be different to the rim recommended by MICHELIN). • (2) MICHELIN rating, value measured on rim recommended by MICHELIN. • (3) Unique point: load capacity/authorized additional speed pair Load variations according to speed do not apply to the unique point.

See the next table for the recommended inflation pressure

- 15-16 INCHES
- 17.5 INCHES
- 19.5 INCHES
- 20 INCHES
- 20 AND 24 INCHES
- 19.5 AND 22.5 INCHES WIDEBASE
- 22.5 INCHES
- OFF-ROAD SIZES
- MICHELIN AGILIS 3 SIZES
- MICHELIN XCD2 SIZES

MICHELIN DIMENSIONAL DATA

19.5 INCHES

Table of inflation pressure (bar) in relation to maximum load per axle (kg)

Dimension	Tread pattern	Table of inflation pressure (bar) in relation to maximum load per axle (kg)																													
		psi	36	40	44	47	51	54	58	62	65	69	73	76	80	83	87	91	94	98	102	105	109	112	116	120	123	127	131		
		bar	2.50	2.75	3.00	3.25	3.50	3.75	4.00	4.25	4.50	4.75	5.00	5.25	5.50	5.75	6.00	6.25	6.50	6.75	7.00	7.25	7.50	7.75	8.00	8.25	8.50	8.75	9.00		
285/70R19.5	X MULTI Z	single											3810	3980	4140	4310	4480	4640	4810	4970	5140	5300	5470	5640	5800	5970					
		dual												7120	7430	7730	8040	8350	8660	8970	9280	9590	9900	10210	10520	10830	11140				
	XZE2+	single												3680	3840	4000	4160	4320	4480	4640	4800	4960	5120	5280	5440	5600					
		dual												6970	7270	7570	7870	8180	8480	8780	9090	9390	9690	9990	10300	10600					
	X MULTI D	single												3810	3980	4140	4310	4480	4640	4810	4970	5140	5300	5470	5640	5800	5970				
		dual												7120	7430	7730	8040	8350	8660	8970	9280	9590	9900	10210	10520	10830	11140				
	XDE2+	single												3680	3840	4000	4160	4320	4480	4640	4800	4960	5120	5280	5440	5600					
		dual												6970	7270	7570	7870	8180	8480	8780	9090	9390	9690	9990	10300	10600					
305/70R19.5	XZE2+	single											4040	4220	4390	4570	4740	4920	5100	5270	5450	5620	5800	5970	6150						
		dual											7620	7950	8290	8620	8950	9280	9610	9940	10270	10610	10940	11270	11600						
	XDE2+	single											4040	4220	4390	4570	4740	4920	5100	5270	5450	5620	5800	5970	6150						
		dual											7620	7950	8290	8620	8950	9280	9610	9940	10270	10610	10940	11270	11600						

- 15-16 INCHES
- 17.5 INCHES
- 19.5 INCHES
- 20 INCHES
- 20 AND 24 INCHES
- 19.5 AND 22.5 INCHES WIDEBASE
- 22.5 INCHES
- OFF-ROAD SIZES
- MICHELIN AGILIS 3 SIZES
- MICHELIN XCD2 SIZES

Dimensional data for general indication only, for official data consult MICHELIN Technical Correspondent.

MICHELIN DIMENSIONAL DATA

20 INCHES

Dimension	Tread Pattern	Category	Type	PR (Ply Rating)	Load / Speed Index	Unique point (3)	Normal pressure for unique point (bar)	Original tread depth	Nominal load per axle (single) (kg)	Nominal pressure for load (single) (bar)	Nominal load per axle (dual) (kg)	Nominal pressure for load (dual) (bar)	Maximum section width in service (mm)	Maximum diameter in service (mm) (1)	Rolling circumference (mm)	Approved rim(s) ETRTO	Laden section width (mm) (2)	Free section width (mm) (2)	Diameter (mm) (2)	Static laden radius (mm) (2)	Rolling circumference (mm) (2)	Minimum dual spacing (mm) (2)	Recommended rim(s) by MICHELIN	Tube	Flap	Seal
8.25R20	XZE	6	TT		133/131K	133/131L	6.50	11.6	4120	6.50	7800	6.50	239	980	2989	5.5-85.5-6.0 6.00T-B6.0-6.5 B6.5-7.0-B7.0	256	232	962	451	2950	263	6.50	20 K	20x7.50	
9.00R20	XZE 2	2	TT	16	144/142K			13.7	5600	9.00	10600	9.00				6.0-6.00T 6.5-7.0-7.5	283	256	1017	476.5	3115	290	7.00	20 M	20x7.50	
10.00R20	XZE 3 R	2	TT	16	147/143K			12.5	6150	8.00	10900	8.00	286	1074	3276	6.50-7.00-7.50	307	277	1049	489	3212	314	7.50	20 N	20x7.50	
	XZE 2	2	TT	16	147/143K	146/143L	7.75	13.8	6150	8.00	10900	8.00	286	1074	3276	6.50-7.00-7.50	307	277	1053	490	3211	314	7.50	20 N	20x7.50	
	XZY3 HD	3	TT	16	147/143K			15.6	6150	7.90	10900	7.90	286	1074	3276	6.50-7.00 7.50-8.00	309	277	1057	495		313	7.50	20 N	20x7.50	
	XZY 3	3	TT	16	147/143K			16.6	6150	8.00	10900	8.00	286	1073	3273	7.0-7.33	311	280	1060	494	3226	317	7.50	20 N	20x7.50	
	XDY3 HD	3	TT	16	147/143K			19.8	6150	7.90	10900	7.90	286	1074	3276	6.50-7.00 7.50-8.00	309	279	1059	493	3240	316	7.50	20 N	20x7.50	
	XDY 3	3	TT	16	147/143K			19.8	6150	8.00	10900	8.00	286	1073	3273	7.0-7.33-7.5-8.0	310	281	1064	497	3240	318	7.50	20 N	20x7.50	

• (1) ETRTO rating (standard value, the ETRTO standard rim may be different to the rim recommended by MICHELIN). • (2) MICHELIN rating, value measured on rim recommended by MICHELIN. • (3) Unique point: load capacity/authorized additional speed pair Load variations according to speed do not apply to the unique point.

See the next table for the recommended inflation pressure

- 15-16 INCHES
- 17.5 INCHES
- 19.5 INCHES
- 20 INCHES
- 20 AND 24 INCHES
- 19.5 AND 22.5 INCHES WIDEBASE
- 22.5 INCHES
- OFF-ROAD SIZES
- MICHELIN AGILIS 3 SIZES
- MICHELIN XCD2 SIZES

MICHELIN DIMENSIONAL DATA

20 INCHES

Table of inflation pressure (bar) in relation to maximum load per axle (kg)

Dimension	Tread pattern	Table of inflation pressure (bar) in relation to maximum load per axle (kg)																														
		psi	36	40	44	47	51	54	58	62	65	69	73	76	80	83	87	91	94	98	102	105	109	112	116	120	123	127	131	134		
		bar	2.50	2.75	3.00	3.25	3.50	3.75	4.00	4.25	4.50	4.75	5.00	5.25	5.50	5.75	6.00	6.25	6.50	6.75	7.00	7.25	7.50	7.75	8.00	8.25	8.50	8.75	9.00	9.25		
8.25R20	XZE	single					2420	2560	2700	2840	2980	3130	3270	3410	3550	3690	3840	3980	4120													
		dual					4570	4840	5110	5380	5650	5920	6190	6460	6720	6990	7260	7530	7800													
9.00R20	16PR	single															3880	4020	4160	4310	4450	4590	4740	4880	5030	5170	5310	5460	5600			
		dual															7340	7610	7880	8150	8430	8700	8970	9240	9510	9780	10060	10330	10600			
10.00R20	XZE 3 R	single											4040	4220	4390	4570	4740	4920	5100	5270	5450	5620	5800	5970	6150							
		dual											7160	7470	7790	8100	8410	8720	9030	9340	9650	9970	10280	10590	10900							
	XZE 2	single											4040	4220	4390	4570	4740	4920	5100	5270	5450	5620	5800	5970	6150							
		dual											7160	7470	7790	8100	8410	8720	9030	9340	9650	9970	10280	10590	10900							
	XZY3 HD	single											4090	4270	4440	4620	4800	4980	5150	5330	5510	5690	5870	6040								
		dual											7250	7560	7880	8190	8510	8820	9140	9450	9770	10080	10400	10710								
	XZY 3	single											4040	4220	4390	4570	4740	4920	5100	5270	5450	5620	5800	5970	6150							
		dual											7160	7470	7790	8100	8410	8720	9030	9340	9650	9970	10280	10590	10900							
	XDY3 HD	single											4090	4270	4440	4620	4800	4980	5150	5330	5510	5690	5870	6040								
		dual											7250	7560	7880	8190	8510	8820	9140	9450	9770	10080	10400	10710								
	XDY 3	single											4040	4220	4390	4570	4740	4920	5100	5270	5450	5620	5800	5970	6150							
		dual											7160	7470	7790	8100	8410	8720	9030	9340	9650	9970	10280	10590	10900							

- 15-16 INCHES
- 17.5 INCHES
- 19.5 INCHES
- 20 INCHES
- 20 AND 24 INCHES
- 19.5 AND 22.5 INCHES WIDEBASE
- 22.5 INCHES
- OFF-ROAD SIZES
- MICHELIN AGILIS 3 SIZES
- MICHELIN XCD2 SIZES

Dimensional data for general indication only, for official data consult MICHELIN Technical Correspondent.

MICHELIN DIMENSIONAL DATA

20 INCHES

Dimension	Tread Pattern	Category	Type	PR (Ply Rating)	Load / Speed Index	Unique point (3)	Normal pressure for unique point (bar)	Original tread depth	Nominal load per axle (single) (kg)	Nominal pressure for load (single) (bar)	Nominal load per axle (dual) (kg)	Nominal pressure for load (dual) (bar)	Maximum section width in service (mm)	Maximum diameter in service (mm) (1)	Rolling circumference (mm)	Approved rim(s) ETRTO	Laden section width (mm) (2)	Free section width (mm) (2)	Diameter (mm) (2)	Static laden radius (mm) (2)	Rolling circumference (mm) (2)	Minimum dual spacing (mm) (2)	Recommended rim(s) by MICHELIN	Tube	Flap	Seal
11.00R20	XZE 3 R	2	TT	16	150/146K	150/147J	8.00	12.3	6700	8.00	12000	8.00	297	1104	3367	6.50-7.0-7.5 7.33-8.0	324	295	1081	503	3311	334	8.00	20 P	20x8.50	
	XZE 2	2	TT	16	147/143K			13.8	6150	8.00	10900	8.00	286	1074	3276	6.50-7.0-7.5 7.33-8.0	307	277	1053	490	3211	314	7.50	20 N	20x8.50	
	XZE 2	2	TT	16	150/146K			14.3	6700	8.00	12000	8.00	297	1104	3367	7.33V-7.5-8.0 8.5-8.50V	329	297	1082	503	3303	336	8.00	20 P	20x8.50	
	XZY 3	3	TT	16	150/146K			17.5	6700	8.00	12000	8.00	297	1104	3367	7.5-8.0-8.0V 8.5-8.50V	330	298	1090	506	3327	337	8.00	20 P	20x8.50	
	XDY 3	3	TT	16	150/146K			20.8	6700	8.00	12000	8.00	297	1104	3367	7.33-7.50-8.00 8.50-9.00	331	300	1096	509	3329	340	8.00	20 P	20x8.50	
12.00R20	XZE 2	2	TT	18	154/150K			15.2	7500	8.50	13400	8.50	319	1146	3495	8.00V-8.5 8.50V-9.00V	345	313	1121	521	3420	354	8.50	20 Q	20x8.50	
	XZY 3	3	TT	18	154/150K			18.1	7500	8.50	13400	8.50	319	1146	3495	7.33-8.00	348	315	1129	527	3451	357	8.50	20 Q	20x8.50	

• (1) ETRTO rating (standard value, the ETRTO standard rim may be different to the rim recommended by MICHELIN). • (2) MICHELIN rating, value measured on rim recommended by MICHELIN. • (3) Unique point: load capacity/authorized additional speed pair Load variations according to speed do not apply to the unique point.

See the next table for the recommended inflation pressure

- 15-16 INCHES
- 17.5 INCHES
- 19.5 INCHES
- 20 INCHES
- 20 AND 24 INCHES
- 19.5 AND 22.5 INCHES WIDEBASE
- 22.5 INCHES
- OFF-ROAD SIZES
- MICHELIN AGILIS 3 SIZES
- MICHELIN XCD2 SIZES

MICHELIN DIMENSIONAL DATA

20 INCHES

Table of inflation pressure (bar) in relation to maximum load per axle (kg)

Dimension	Tread pattern	Table of inflation pressure (bar) in relation to maximum load per axle (kg)																														
		psi	36	40	44	47	51	54	58	62	65	69	73	76	80	83	87	91	94	98	102	105	109	112	116	120	123	127	131	134		
		bar	2.50	2.75	3.00	3.25	3.50	3.75	4.00	4.25	4.50	4.75	5.00	5.25	5.50	5.75	6.00	6.25	6.50	6.75	7.00	7.25	7.50	7.75	8.00	8.25	8.50	8.75	9.00	9.25		
11.00R20	XZE 3 R	single											4400	4590	4790	4980	5170	5360	5550	5740	5930	6130	6320	6510	6700							
		dual												7890	8230	8570	8910	9260	9600	9940	10290	10630	10970	11310	11660	12000						
	XZE 2	single												4040	4220	4390	4570	4740	4920	5100	5270	5450	5620	5800	5970	6150						
		dual												7160	7470	7790	8100	8410	8720	9030	9340	9650	9970	10280	10590	10900						
	XZE 2	single												4400	4590	4790	4980	5170	5360	510	5740	5930	6130	6320	6510	6700						
		dual												7890	8230	8570	8910	9260	9600	9940	10290	10630	10970	11310	11660	12000						
	XZY 3	single												4400	4590	4790	4980	5170	5360	510	5740	5930	6130	6320	6510	6700						
		dual												7890	8230	8570	8910	9260	9600	9940	10290	10630	10970	11310	11660	12000						
	XDY 3	single												4400	4590	4790	4980	5170	5360	5550	5740	5930	6130	6320	6510	6700						
		dual												7890	8230	8570	8910	9260	9600	9940	10290	10630	10970	11310	11660	12000						
	12.00R20	XZE 2	single														5070	5270	5470	5680	5880	6080	6280	6490	6690	6890	7090	7300	7500			
			dual														9050	9420	9780	10140	10500	10860	11230	11590	11950	12310	12680	13040	13400			
XZY 3		single												5070	5270	5470	5680	5880	6080	6280	6490	6690	6890	7090	7300	7500						
		dual												9050	9420	9780	10140	10500	10860	11230	11590	11950	12310	12680	13040	13400						

- 15-16 INCHES
- 17.5 INCHES
- 19.5 INCHES
- 20 INCHES
- 20 AND 24 INCHES
- 19.5 AND 22.5 INCHES WIDEBASE
- 22.5 INCHES
- OFF-ROAD SIZES
- MICHELIN AGILIS 3 SIZES
- MICHELIN XCD2 SIZES

Dimensional data for general indication only, for official data consult MICHELIN Technical Correspondent.

MICHELIN DIMENSIONAL DATA

20 AND 24 INCHES

Dimension	Tread Pattern	Category	Type	PR (Ply Rating)	Load / Speed Index	Unique point (3)	Normal pressure for unique point (bar)	Original tread depth	Nominal load per axle (single) (kg)	Nominal pressure for load (single) (bar)	Nominal load per axle (dual) (kg)	Nominal pressure for load (dual) (bar)	Maximum section width in service (mm)	Maximum diameter in service (mm) (1)	Rolling circumference (mm)	Approved rim(s) ETRTO	Laden section width (mm) (2)	Free section width (mm) (2)	Diameter (mm) (2)	Static laden radius (mm) (2)	Rolling circumference (mm) (2)	Minimum dual spacing (mm) (2)	Recommended rim(s) by MICHELIN	Tube	Flap	Seal
12.00R20	XZH2 R	3	TL		154/149G	156F	9.00	22.0	7500	8.50	13000	8.50	319	1146	3495	7.33V-8.0-8.0V 88.0-8.5-8.50V 88.5-9.0-9.00V	350	319	1140	531	3468	360	8.50		20x8.50	
	XDY 3	3	TT	18	154/150K			21.0	7500	8.50	13400	8.50	319	1158	3532	7.33 - 8.00	351	318	1135	529	3456	361	8.50	20 Q	20x8.50	
325/95R24	X WORKS XZ	3	TL		162/160K			19.0	9500	8.50	18000	8.50	327	1252	3819	8.50	347	311	1223	566	3747	352	8.50		24/25x8.50	
	X WORKS XD	3	TL		162/160K			22.0	9500	8.50	18000	8.50	327	1265	3858	8.50	348	314	1230	570	3760	355	8.50		24/25x8.50	

• (1) ETRTO rating (standard value, the ETRTO standard rim may be different to the rim recommended by MICHELIN). • (2) MICHELIN rating, value measured on rim recommended by MICHELIN. • (3) Unique point: load capacity/authorized additional speed pair Load variations according to speed do not apply to the unique point.

See the next table for the recommended inflation pressure

- 15-16 INCHES
- 17.5 INCHES
- 19.5 INCHES
- 20 INCHES
- 20 AND 24 INCHES
- 19.5 AND 22.5 INCHES WIDEBASE
- 22.5 INCHES
- OFF-ROAD SIZES
- MICHELIN AGILIS 3 SIZES
- MICHELIN XCD2 SIZES

MICHELIN DIMENSIONAL DATA

20 AND 24 INCHES

Table of inflation pressure (bar) in relation to maximum load per axle (kg)

Dimension	Tread pattern	psi	Inflation pressure (bar)																															
			36	40	44	47	51	54	58	62	65	69	73	76	80	83	87	91	94	98	102	105	109	112	116	120	123	127	131	134				
			2.50	2.75	3.00	3.25	3.50	3.75	4.00	4.25	4.50	4.75	5.00	5.25	5.50	5.75	6.00	6.25	6.50	6.75	7.00	7.25	7.50	7.75	8.00	8.25	8.50	8.75	9.00	9.25				
12.00R20	XZH2 R	single												4500	4690	4880	5070	5270	5470	5680	5880	6080	6280	6490	6690	6890	7090	7300	7500					
		dual													7800	8130	8450	8780	9140	9490	9840	10190	10540	10890	11240	11590	11950	12300	12650	13000				
	XDY 3	single																5070	5270	5470	5680	5880	6080	6280	6490	6690	6890	7090	7300	7500				
		dual																	9050	9420	9780	10140	10500	10860	11230	11590	11950	12310	12680	13040	13400			
325/95R24	XWORKS XZ	single																		6930	7190	7450	7700	7960	8220	8470	8730	8990	9240	9500				
		dual																			13140	13620	14110	14590	15080	15570	16050	16540	17030	17510	18000			
	XWORKS XD	single																			6930	7190	7450	7700	7960	8220	8470	8730	8990	9240	9500			
		dual																				13140	13620	14110	14590	15080	15570	16050	16540	17030	17510	18000		

- 15-16 INCHES
- 17.5 INCHES
- 19.5 INCHES
- 20 INCHES
- 20 AND 24 INCHES
- 19.5 AND 22.5 INCHES WIDEBASE
- 22.5 INCHES
- OFF-ROAD SIZES
- MICHELIN AGILIS 3 SIZES
- MICHELIN XCD2 SIZES

Dimensional data for general indication only, for official data consult MICHELIN Technical Correspondent.

MICHELIN DIMENSIONAL DATA

19.5 AND 22.5 INCHES WIDEBASE

Dimension	Tread Pattern	Category	Type	PR (Ply Rating)	Load / Speed Index	Unique point (3)	Normal pressure for unique point (bar)	Original tread depth	Nominal load per axle (single) (kg)	Nominal pressure for load (single) (bar)	Nominal load per axle (dual) (kg)	Nominal pressure for load (dual) (bar)	Maximum section width in service (mm)	Maximum diameter in service (mm) (1)	Rolling circumference (mm)	Approved rim(s) ETRTO	Laden section width (mm) (2)	Free section width (mm) (2)	Diameter (mm) (2)	Static laden radius (mm) (2)	Rolling circumference (mm) (2)	Minimum dual spacing (mm) (2)	Recommended rim(s) by MICHELIN	Tube	Flap	Seal
445/45R19.5	XTA2 ENERGY	1	TL		160J			13.0	9000	9.00						14.00	463	436	903	413	2761		14.00			
445/50R22.5	X ONE LINE ENERGY D	1	TL		LRL			19.2	9250	8.25						14.00		1021	471				14.00			
	X ONE LINE ENERGY T	1	TL	20	LRL			10.3	9250	8.25			463	1036		14.00	464	435	1004	465			14.00			
	X ONE MULTI ENERGY T	2	TL	20	LRL			12.9	9250	8.25			463	1036		14.00	458	433	1008	467			14.00			
	X ONE XTE	2	TL		LRL			12.7	9250	8.25						14.00	460	435	1008	465	3094		14.00			
	X ONE LINE D	1	TL	20	LRL			19.2	9250	8.25			463	1036		14.00	464	434	1020	471			14.00			
	X ONE LINE GRIP D	2	TL	20	LRL			21.8	9250	8.25			463	1036		14.00	464	435	1026	473			14.00			
385/55R22.5	XFA2 ENERGY	1	TL		158L	160J	9.00	13.0	8500	9.00			401	1012	3087	11.75	406	380	997	461	3040		11.75			
	X MULTI T	2	TL		160K	158L	8.50	13.0	9000	9.00			401	1012	3087	11.75	406	378	998	460	3068		11.75			
	X ENERGY SAVERGREEN XT	1	TL		160J	158L	8.50	14.3	9000	9.00			381	996	3038	11.75	406	380	1002	463	3072		11.75			
	X MULTI T2	2	TL		160K	158L	9.00	14.9	4500	9.00			401	1012	3087	11.75 - 12.25	410	381	1001	461	3071		11.75			
	X LINE ENERGY T	1	TL		160K	158L	9.00	11.3	4500	9.00			401	1012	3087	11.75 - 12.25	403	376	996	458	3060		11.75			
455/55R22.5	X ONE XZY3	3	TL		LRM			10.3	10600	9.00						14.00	480	452	1065	492	3245		14.00			
	X ONE XZU S	5	TL		LRM			18.7	10600	9.00						14.00	480	452	1095	492	3245		14.00			
	X ONE XDN2	2	TL		LRL			21.6	10000	9.00						14.00		1076	497				14.00			
	X ONE X MULTI ENERGY T	2	TL		LRL			12.8	10000	9.00						14.00		1058	490				14.00			
	X ONE XTE*	2	TL		LRL			12.7	10000	8.50						14.00	446	1058	488	3244			14.00			
	X ONE LINE GRIP D	2	TL	20	164L			21.8	1000	8.30			470	1092		14.00	474	442	1071	495	3252		14.00			

• (1) ETRTO rating (standard value, the ETRTO standard rim may be different to the rim recommended by MICHELIN). • (2) MICHELIN rating, value measured on rim recommended by MICHELIN. • (3) Unique point: load capacity/authorized additional speed pair Load variations according to speed do not apply to the unique point.

See the next table for the recommended inflation pressure

- 15-16 INCHES
- 17.5 INCHES
- 19.5 INCHES
- 20 INCHES
- 20 AND 24 INCHES
- 19.5 AND 22.5 INCHES WIDEBASE
- 22.5 INCHES
- OFF-ROAD SIZES
- MICHELIN AGILIS 3 SIZES
- MICHELIN XCD2 SIZES

MICHELIN DIMENSIONAL DATA

19.5 AND 22.5 INCHES WIDEBASE

Table of inflation pressure (bar) in relation to maximum load per axle (kg)

Dimension	Tread pattern	Table of inflation pressure (bar) in relation to maximum load per axle (kg)																																		
		psi	36	40	44	47	51	54	58	62	65	69	73	76	80	83	87	91	94	98	102	105	109	112	116	120	123	127	131							
		bar	2.50	2.75	3.00	3.25	3.50	3.75	4.00	4.25	4.50	4.75	5.00	5.25	5.50	5.75	6.00	6.25	6.50	6.75	7.00	7.25	7.50	7.75	8.00	8.25	8.50	8.75	9.00							
445/45R19.5	XTA2 ENERGY	single																			6230	6460	6690	6920	7150	7380	7620	7850	8080	8310	8540	8770	9000			
445/50R22.5	X ONE LINE ENERGY D	single																																		
	X ONE LINE ENERGY T	single																																		
	X ONE MULTI ENERGY T	single																																		
	X ONE XTE	single																																		
	X ONE LINE D	single																																		
	X ONE LINE GRIP D	single																																		
385/55R22.5	XFA2 ENERGY	single																																		
	X MULTI T	single																																		
	X ENERGY SAVERGREEN XT	single																																		
	X MULTI T2	single																																		
	X LINE ENERGY T	single																																		
		X LINE ENERGY T	single																																	
455/55R22.5	X ONE XZY3	single																																		
	X ONE XZU S	single																																		
	X ONE XDN2	single																																		
	X ONE X MULTI ENERGY T	single																																		
	X ONE XTE*	single																																		
	X ONE LINE GRIP D	single																																		

- 15-16 INCHES
- 17.5 INCHES
- 19.5 INCHES
- 20 INCHES
- 20 AND 24 INCHES
- 19.5 AND 22.5 INCHES WIDEBASE
- 22.5 INCHES
- OFF-ROAD SIZES
- MICHELIN AGILIS 3 SIZES
- MICHELIN XCD2 SIZES

Dimensional data for general indication only, for official data consult MICHELIN Technical Correspondent.

MICHELIN DIMENSIONAL DATA

19.5 AND 22.5 INCHES WIDEBASE

Dimension	Tread Pattern	Category	Type	PR (Ply Rating)	Load / Speed Index	Unique point (3)	Normal pressure for unique point (bar)	Original tread depth	Nominal load per axle (single) (kg)	Nominal pressure for load (single) (bar)	Nominal load per axle (dual) (kg)	Nominal pressure for load (dual) (bar)	Maximum section width in service (mm)	Maximum diameter in service (mm) (1)	Rolling circumference (mm)	Approved rim(s) ETRTO	Laden section width (mm) (2)	Free section width (mm) (2)	Diameter (mm) (2)	Static laden radius (mm) (2)	Rolling circumference (mm) (2)	Minimum dual spacing (mm) (2)	Recommended rim(s) by MICHELIN	Tube	Flap	Seal
385/65R22.5	X MULTI F	2	TL		158L	160K	9.00	12.5	8500	8.50			405	1092	3331	11.75	404	376	1073	497	3288		11.75			
	X LINE ENERGY F	1	TL		160K	158L	9.00	12.0	9000	9.00			405	1092	3331	11.75	405	376	1066	495	3270		11.75			
	XFE	2	TL		160K			16.3	9000	9.00			405	1092	3331	11.75	404	379	1072	499	3270		11.75			
	XFN 2	2	TL		158/L	160J	9.00	15.4	8500	8.50			405	1103	3364	11.75 - 12.25	409	380	1074	498	3274		11.75			
	X MULTIWAY HD XZE	2	TL		164K			15.3	10000	9.00			405	1103	3364	11.75	414	384	1078	497	3309		11.75			
	XZY 3	3	TL		160K	158L	8.50	17.7	9000	9.00			405	1092	3331	11.75 - 12.25	409	379	1078	499	3280		11.75			
	X LINE ENERGY T	1	TL		160K	158L	8.50	12.4	9000	9.00			405	1103	3364	11.75	406	377	1066	494	3272		11.75			
	X MULTI T	2	TL		160K	158L	8.50	15.3	9000	9.00			405	1103	3364	11.75	403	377	1070	496	3286		11.75			
	X ENERGY SAVERGREEN XT	1	TL		160J	158L	8.50	16.0	9000	9.00			389	1072	3270	11.75	407	376	1072	498	3286		11.75			
	XTE 3	2	TL		160J	158L	8.50	17.3	9000	9.00			389	1092	3331	11.75	407	378	1074	497	3292		11.75			
X MULTI Z	2	TL		160K	158L	9.00	13.5	9000	9.00			405	1092	3248	17.50 - 12.25	410	376	1067	493	3271		11.75				
425/65R22.5	XZY 3	3	TL	20	165K			18.1	10300	8.50			430	1157	3529	13.00 - 14.00	453	421	1136	523	3460		13.00			
	XTE2	2	TL	20	165K			16.3	10300	8.50			447	1046	3190	13.00 - 14.00	449	421	1130	522	3440		13.00			
445/65R22.5	XZY 3	3	TL		169K			18.5	11600	9.00			472	1174	3581	14.00	486	451	1164	536	3540		14.00			
	XTE2	2	TL	20	169K			16.8	11600	9.00			472	1174	3581	14.00	481	451	1158	534	3520		14.00			

• (1) ETRTO rating (standard value, the ETRTO standard rim may be different to the rim recommended by MICHELIN). • (2) MICHELIN rating, value measured on rim recommended by MICHELIN. • (3) Unique point: load capacity/authorized additional speed pair Load variations according to speed do not apply to the unique point.

See the next table for the recommended inflation pressure

- 15-16 INCHES
- 17.5 INCHES
- 19.5 INCHES
- 20 INCHES
- 20 AND 24 INCHES
- 19.5 AND 22.5 INCHES WIDEBASE
- 22.5 INCHES
- OFF-ROAD SIZES
- MICHELIN AGILIS 3 SIZES
- MICHELIN XCD2 SIZES

MICHELIN DIMENSIONAL DATA

19.5 AND 22.5 INCHES WIDEBASE

Table of inflation pressure (bar) in relation to maximum load per axle (kg)

Dimension	Tread pattern	Table of inflation pressure (bar) in relation to maximum load per axle (kg)																											
		psi	36	40	44	47	51	54	58	62	65	69	73	76	80	83	87	91	94	98	102	105	109	112	116	120	123	127	131
		bar	2.50	2.75	3.00	3.25	3.50	3.75	4.00	4.25	4.50	4.75	5.00	5.25	5.50	5.75	6.00	6.25	6.50	6.75	7.00	7.25	7.50	7.75	8.00	8.25	8.50	8.75	9.00
385/65R22.5	X MULTI F	single															6200	6430	6660	6890	7120	7350	7580	7810	8040	8270	8500		
	X LINE ENERGY F	single															6230	6460	6690	6920	7150	7380	7620	7850	8080	8310	8540	8770	9000
	XFE	single															6230	6460	6690	6920	7150	7380	7620	7850	8080	8310	8540	8770	9000
	XFN 2	single													5740	5970	6200	6430	6660	6890	7120	7350	7580	7810	8040	8270	8500		
	X MULTIWAY HD XZE	single															6920	7180	7440	7690	7950	8210	8460	8720	8970	9230	9490	9740	10000
	XZY 3	single															6230	6460	6690	6920	7150	7380	7620	7850	8080	8310	8540	8770	9000
	X LINE ENERGY T	single															6230	6460	6690	6920	7150	7380	7620	7850	8080	8310	8540	8770	9000
	X MULTI T	single															6230	6460	6690	6920	7150	7380	7620	7850	8080	8310	8540	8770	9000
	X ENERGY SAVERGREEN XT	single															6230	6460	6690	6920	7150	7380	7620	7850	8080	8310	8540	8770	9000
	XTE 3	single															6230	6460	6690	6920	7150	7380	7620	7850	8080	8310	8540	8770	9000
X MULTI Z	single															6230	6460	6690	6920	7150	7380	7620	7850	8080	8310	8540	8770	9000	
425/65R22.5	XZY 3	single															7520	7790	8070	8350	8630	8910	9190	9460	9740	10020	10300		
	XTE2	single													6960	7240	7520	7790	8070	8350	8630	8910	9190	9460	9740	10020	10300		
445/65R22.5	XZY 3	single															8030	8330	8630	8920	9220	9520	9820	10110	10410	10710	11010	11300	11600
	XTE2	single															8030	8330	8630	8920	9220	9520	9820	10110	10410	10710	11010	11300	11600

- 15-16 INCHES
- 17.5 INCHES
- 19.5 INCHES
- 20 INCHES
- 20 AND 24 INCHES
- 19.5 AND 22.5 INCHES WIDEBASE
- 22.5 INCHES
- OFF-ROAD SIZES
- MICHELIN AGILIS 3 SIZES
- MICHELIN XCD2 SIZES

Dimensional data for general indication only, for official data consult MICHELIN Technical Correspondent.

MICHELIN DIMENSIONAL DATA

22.5 INCHES

Dimension	Tread Pattern	Category	Type	PR (Ply Rating)	Load / Speed Index	Unique point (3)	Normal pressure for unique point (bar)	Original tread depth	Nominal load per axle (single) (kg)	Nominal pressure for load (single) (bar)	Nominal load per axle (dual) (kg)	Nominal pressure for load (dual) (bar)	Maximum section width in service (mm)	Maximum diameter in service (mm) (1)	Rolling circumference (mm)	Approved rim(s) ETRTO	Laden section width (mm) (2)	Free section width (mm) (2)	Diameter (mm) (2)	Static laden radius (mm) (2)	Rolling circumference (mm) (2)	Minimum dual spacing (mm) (2)	Recommended rim(s) by MICHELIN	Tube	Flap	Seal
9R22.5	XZA	6	TL		133/131L			13.0	4120	6.50	7800	6.50	239	986	3007	6.00 - 6.75	245	222	965	450	2950	251	6.00			
	XZY	3	TL		133/131K			13.8	4120	6.50	7800	6.50	239	986	3007	6.00 - 6.75	246	219	969	450	2960	248	6.00			
10R22.5	XZA	2	TL		144/142L			15.0	5600	8.00	10600	8.00	264	1038	3166	6.75 - 7.50	270	245	1014	473	3100	277	6.75			
	XZY	3	TL		144/142K			13.9	5600	8.00	10600	8.00	264	1038	3166	6.75 - 7.50	271	244	1017	473	3110	276	6.75			
11R22.5	X MULTI Z	2	TL	16	148/145L			13.8	6300	8.00	11600	8.00	290	1070	3264	7.50 - 8.25	302	281	1048	492	3267	314	8.25			
	X INCITY Z	5	TL	16	148/145J	151/148E	8.30	16.0	6300	8.30	11600	8.30	290	1070	3264	7.50 - 8.25	308	282	1054	492	3221	320	8.25			
	X COACH ENERGY Z	8	TL		148/145M			13.8	6300	8.00	11600	8.00	290	1070	3264	7.50 - 8.25	302	281	1048	492	3267	314	8.25			
	XZA 2+ ENERGY	1	TL		148/145M			14.7	6300	8.00	11600	8.00	290	1070	3264	7.50 - 8.25	299	267	1056	489	3228	302	7.50			
	XJE4 MIX ENERGY	1	TL	16	148/145L			14.3	6300	8.00	11600	8.00	279	1037	3163	7.50 - 8.25	304	275	1048	486	3198	311	7.50			
	XJW4+	2	TL	16	148/145L			16.3	6300	8.00	11600	8.00	279	1037	3163	7.50 - 8.25	303	275	1054	490	3220	311	7.50			
	XZE2+	2	TL	16	148/145L			15.2	6300	8.00	11600	8.00	290	1070	3264	7.50 - 8.25	303	273	1055	490	3225	309	7.50			
	X MULTI Z2	2	TL	16	148/145L			14.5	6300	8.50	11600	8.50	290	1070	3264	7.50 - 8.25	299	272	1044	488	3200		7.50			

• (1) ETRTO rating (standard value, the ETRTO standard rim may be different to the rim recommended by MICHELIN). • (2) MICHELIN rating, value measured on rim recommended by MICHELIN. • (3) Unique point: load capacity/authorized additional speed pair Load variations according to speed do not apply to the unique point.

See the next table for the recommended inflation pressure

Dimensional data for general indication only, for official data consult MICHELIN Technical Correspondent.

- 15-16 INCHES
- 17.5 INCHES
- 19.5 INCHES
- 20 INCHES
- 20 AND 24 INCHES
- 19.5 AND 22.5 INCHES WIDEBASE
- 22.5 INCHES
- OFF-ROAD SIZES
- MICHELIN AGILIS 3 SIZES
- MICHELIN XCD2 SIZES

MICHELIN DIMENSIONAL DATA

22.5 INCHES

Table of inflation pressure (bar) in relation to maximum load per axle (kg)

Dimension	Tread pattern	Table of inflation pressure (bar) in relation to maximum load per axle (kg)																													
		psi	36	40	44	47	51	54	58	62	65	69	73	76	80	83	87	91	94	98	102	105	109	112	116	120	123	127	131		
		bar	2.50	2.75	3.00	3.25	3.50	3.75	4.00	4.25	4.50	4.75	5.00	5.25	5.50	5.75	6.00	6.25	6.50	6.75	7.00	7.25	7.50	7.75	8.00	8.25	8.50	8.75	9.00		
9R22.5	XZA	single					2420	2560	2700	2840	2980	3130	3270	3410	3550	3690	3840	3980	4120												
		dual					4570	4840	5110	5380	5650	5920	6190	6460	6720	6990	7260	7530	7800												
	XZY	single					2420	2560	2700	2840	2980	3130	3270	3410	3550	3690	3840	3980	4120												
		dual					4570	4840	5110	5380	5650	5920	6190	6460	6720	6990	7260	7530	7800												
10R22.5	XZA	single											3680	3840	4000	4160	4320	4480	4640	4800	4960	5120	5280	5440	5600						
		dual											6970	7270	7570	7870	8180	8480	8780	9090	9390	9690	9990	10300	10600						
	XZY	single											3680	3840	4000	4160	4320	4480	4640	4800	4960	5120	5280	5440	5600						
		dual											6970	7270	7570	7870	8180	8480	8780	9090	9390	9690	9990	10300	10600						
11R22.5	X MULTI Z	single											4140	4320	4500	4680	4860	5040	5220	5400	5580	5760	5940	6120	6300						
		dual											7620	7950	8290	8620	8950	9280	9610	9940	10270	10610	10940	11270	11600						
	X INCITY Z	single												4180	4350	4520	4700	4870	5050	5220	5400	5570	5740	5920	6090	6270					
		dual												7690	8010	8330	8650	8970	9290	9610	9930	10250	10570	10900	11220	11540					
	X COACH ENERGY Z	single											4140	4320	4500	4680	4860	5040	5220	5400	5580	5760	5940	6120	6300						
		dual											7620	7950	8290	8620	8950	9280	9610	9940	10270	10610	10940	11270	11600						
	XZA 2+ ENERGY	single											4140	4320	4500	4680	4860	5040	5220	5400	5580	5760	5940	6120	6300						
		dual											7620	7950	8290	8620	8950	9280	9610	9940	10270	10610	10940	11270	11600						
	XJE4 MIX ENERGY	single											4140	4320	4500	4680	4860	5040	5220	5400	5580	5760	5940	6120	6300						
		dual											7620	7950	8290	8620	8950	9280	9610	9940	10270	10610	10940	11270	11600						
	XJW4+	single											4140	4320	4500	4680	4860	5040	5220	5400	5580	5760	5940	6120	6300						
		dual											7620	7950	8290	8620	8950	9280	9610	9940	10270	10610	10940	11270	11600						
	XZE2+	single											4140	4320	4500	4680	4860	5040	5220	5400	5580	5760	5940	6120	6300						
		dual											7620	7950	8290	8620	8950	9280	9610	9940	10270	10610	10940	11270	11600						
	X MULTI Z2	single											3920	4070	4230	4400	4570	4750	4920	5100	5280	5460	5620	5780	5930	6110	6300				
		dual											7250	7560	7870	8180	8500	8810	9120	9430	9750	10060	10360	10670	10980	1129	11600				

- 15-16 INCHES
- 17.5 INCHES
- 19.5 INCHES
- 20 INCHES
- 20 AND 24 INCHES
- 19.5 AND 22.5 INCHES WIDEBASE
- 22.5 INCHES
- OFF-ROAD SIZES
- MICHELIN AGILIS 3 SIZES
- MICHELIN XCD2 SIZES

Dimensional data for general indication only, for official data consult MICHELIN Technical Correspondent.

MICHELIN DIMENSIONAL DATA

22.5 INCHES

Dimension	Tread Pattern	Category	Type	PR (Ply Rating)	Load / Speed Index	Unique point (3)	Normal pressure for unique point (bar)	Original tread depth	Nominal load per axle (single) (kg)	Nominal pressure for load (single) (bar)	Nominal load per axle (dual) (kg)	Nominal pressure for load (dual) (bar)	Maximum section width in service (mm)	Maximum diameter in service (mm) (1)	Rolling circumference (mm)	Approved rim(s) ETRTO	Laden section width (mm) (2)	Free section width (mm) (2)	Diameter (mm) (2)	Static laden radius (mm) (2)	Rolling circumference (mm) (2)	Minimum dual spacing (mm) (2)	Recommended rim(s) by MICHELIN	Tube	Flap	Seal
11R22.5	XZY 3	3	TL	16	148/145K			19.0	6300	8.00	11600	8.00	290	1070	3264	7.50	303	275	1060	493	3236	311	7.50			
	XZY-2	3	TL	16	148/145K			18.2	6300	8.00	11600	8.00	290	1070	3264	7.50 - 8.25	305	280	1059	492	3230	316	7.50			
	XZU3+	5	TL	16	148/145J	151/148E	8.00	19.7	6300	8.00	11600	8.00	290	1070	3264	7.50 - 8.25	303	275	1065	495	3227	311	7.50			
	XJS WINTER GRIP+	2	TL	16	148/145J			18.9	6300	8.00	11600	8.00	290	1070	3264	7.50 - 8.25	298	270	1060	493	3240	305	7.50			
	X MULTI D	2	TL	16	148/145L			21.5	6300	8.00	11600	8.00	290	1070	3264	7.50 - 8.25	297	268	1066	496	3234	303	7.50			
	XDE M/S*	2	TL	16	LRH			28.0	6000	8.25	10900	8.25	290	1070	3264	7.50 - 8.25	308	285		493	3238	318	8.25, 7.50			
	XDY 3	3	TL	16	148/145K			21.5	6300	8.00	11600	8.00	290	1070	3264	7.50 - 8.25	306	277	1065	496	3250	314	7.50			
	XDW ICE GRIP	2	TL	16				19.0	6300	8.00	11600	8.00	290	1070	3264	7.50 - 8.25	309	279	1055	491	3220	315	7.50			
	X MULTI T	2	TL	16	148/145L	152/148J	8.30	13.5	6300	8.30	11600	8.30	290	1070	3264	7.50 - 8.25	301	272	1048	487	3206	308	8.25			
	XTE2	2	TL	14	142/142J			13.7	5300	8.00	10600	8.00	269	1064	3245	7.50 - 8.25	293	268	1050	492	3216	303	7.50			
	X MULTI D+	2	TL	16	148/145L			23.5	6300	8.30	11600	8.30	290	1070	3264	7.50 - 8.25	314	284	1067	498	3233	321	8.25			

• (1) ETRTO rating (standard value, the ETRTO standard rim may be different to the rim recommended by MICHELIN). • (2) MICHELIN rating, value measured on rim recommended by MICHELIN. • (3) Unique point: load capacity/authorized additional speed pair Load variations according to speed do not apply to the unique point.

See the next table for the recommended inflation pressure

Dimensional data for general indication only, for official data consult MICHELIN Technical Correspondent.

- 15-16 INCHES
- 17.5 INCHES
- 19.5 INCHES
- 20 INCHES
- 20 AND 24 INCHES
- 19.5 AND 22.5 INCHES WIDEBASE
- 22.5 INCHES
- OFF-ROAD SIZES
- MICHELIN AGILIS 3 SIZES
- MICHELIN XCD2 SIZES

MICHELIN DIMENSIONAL DATA

22.5 INCHES

Table of inflation pressure (bar) in relation to maximum load per axle (kg)

Dimension	Tread pattern	Table of inflation pressure (bar) in relation to maximum load per axle (kg)																														
		psi	36	40	44	47	51	54	58	62	65	69	73	76	80	83	87	91	94	98	102	105	109	112	116	120	123	127	131			
		bar	2.50	2.75	3.00	3.25	3.50	3.75	4.00	4.25	4.50	4.75	5.00	5.25	5.50	5.75	6.00	6.25	6.50	6.75	7.00	7.25	7.50	7.75	8.00	8.25	8.50	8.75	9.00			
11R22.5	XZY 3	single											4140	4320	4500	4680	4860	5040	5220	5400	5580	5760	5940	6120	6300							
		dual												7620	7950	8290	8620	8950	9280	9610	9940	10270	10610	10940	11270	11600						
	XZY-2	single												4140	4320	4500	4680	4860	5040	5220	5400	5580	5760	5940	6120	6300						
		dual												7620	7950	8290	8620	8950	9280	9610	9940	10270	10610	10940	11270	11600						
	XZU3+	single												4140	4320	4500	4680	4860	5040	5220	5400	5580	5760	5490	6120	6300						
		dual												7620	7950	8290	8620	8950	9280	9610	9940	10270	10610	10940	11270	11600						
	XJS WINTER GRIP+	single												4140	4320	4500	4680	4860	5040	5220	5400	5580	5760	5490	6120	6300						
		dual												7620	7950	8290	8620	8950	9280	9610	9940	10270	10610	10940	11270	11600						
	X MULTI D	single												4140	4320	4500	4680	4860	5040	5220	5400	5580	5760	5940	6120	6300						
		dual												7620	7950	8290	8620	8950	9280	9610	9940	10270	10610	10940	11270	11600						
	XDE M/S*	single													4360	4520	4650	4840	5040	5200	5320	5480	5600	5710	5790	5900	6000					
		dual													8380	8640	8850	9170	9520	9840	10080	10380	10600	10690	10760	10850	10900					
	XDY 3	single												4140	4320	4500	4680	4860	5040	5220	5400	5580	5760	5940	6120	6300						
		dual												7620	7950	8290	8620	8950	9280	9610	9940	10270	10610	10940	11270	11600						
	XDW ICE GRIP	single												4140	4320	4500	4680	4860	5040	5220	5400	5580	5760	5940	6120	6300						
		dual												7620	7950	8290	8620	8950	9280	9610	9940	10270	10610	10940	11270	11600						
	X MULTI T	single										3820	4010	4150	4340	4480	4700	4870	5050	5220	5400	5570	5740	5920	6090	6270						
		dual										7050	7410	7670	8030	8290	8650	8970	9290	9610	9930	10250	10570	10900	11220	11540						
	XTE2	single												3480	3630	3790	3940	4090	4240	4390	4540	4690	4850	5000	5150	5300						
		dual												6970	7270	7570	7870	8180	8480	8780	9090	9390	9690	9990	10300	10600						
X MULTI D+	single												4140	4320	4500	4680	4860	5040	5220	5400	5580	5760	5940	6120	6300							
	dual												7620	7950	8290	8620	8950	9280	9610	9940	10270	10610	10940	11270	11600							

- 15-16 INCHES
- 17.5 INCHES
- 19.5 INCHES
- 20 INCHES
- 20 AND 24 INCHES
- 19.5 AND 22.5 INCHES WIDEBASE
- 22.5 INCHES
- OFF-ROAD SIZES
- MICHELIN AGILIS 3 SIZES
- MICHELIN XCD2 SIZES

Dimensional data for general indication only, for official data consult MICHELIN Technical Correspondent.

MICHELIN DIMENSIONAL DATA

22.5 INCHES

Dimension	Tread Pattern	Category	Type	PR (Ply Rating)	Load / Speed Index	Unique point (3)	Normal pressure for unique point (bar)	Original tread depth	Nominal load per axle (single) (kg)	Nominal pressure for load (single) (bar)	Nominal load per axle (dual) (kg)	Nominal pressure for load (dual) (bar)	Maximum section width in service (mm)	Maximum diameter in service (mm) (1)	Rolling circumference (mm)	Approved rim(s) ETRTO	Laden section width (mm) (2)	Free section width (mm) (2)	Diameter (mm) (2)	Static laden radius (mm) (2)	Rolling circumference (mm) (2)	Minimum dual spacing (mm) (2)	Recommended rim(s) by MICHELIN	Tube	Flap	Seal
12R22.5	X LINE ENERGY Z	1	TL	18	152/149L			15.6	7100	8.50	13000	8.50	312	1104	3367	8.25 - 9.00	317	287	1084	503	3312	329	8.25			
	X MULTI Z	2	TL	18	152/149L			14.5	7100	8.50	13000	8.50	312	1104	3367	8.25 - 9.00	323	296	1082	505	3314	338	8.25			
	X WORKS XZY	3	TL	16	152/149K			18.5	7100	8.50	13000	8.50	312	1104	3367	8.25 - 9.00	323	290	1092	507	3334	328	8.25			
	XZE2+	2	TL	18	152/149L			15.5	7100	8.50	13000	8.50	312	1104	3367	8.25 - 9.00	318	287	1085	504	3310	325	8.25			
	XZY-2	3	TL	16	152/148K			18.2	7100	8.50	12600	8.50	312	1104	3367	8.25 - 9.00	328	291	1092	507	3330	329	8.25			
	X WORKS XDY	3	TL	16	152/149K			23.2	7100	8.50	13000	8.50	312	1104	3367	8.25 - 9.00	322	292	1096	511	3350	330	8.25			
	XDE2+	2	TL	18	152/149L			23.2	7100	8.50	13000	8.50	312	1104	3367	8.25 - 9.00	319	288	1094	510	3340	326	8.25			
	XDE2+	2	TL	16	152/148L			23.2	7100	8.50	12600	8.50	312	1104	3367	8.25 - 9.00	320	288	1094	510	3340	326	8.25			
	XDY 3	3	TL	16	152/148K			22.3	7100	8.50	12600	8.50	312	1104	3367	8.25 - 9.00	320	290	1097	510	3350	328	8.25			

• (1) ETRTO rating (standard value, the ETRTO standard rim may be different to the rim recommended by MICHELIN). • (2) MICHELIN rating, value measured on rim recommended by MICHELIN. • (3) Unique point: load capacity/authorized additional speed pair Load variations according to speed do not apply to the unique point.

See the next table for the recommended inflation pressure

- 15-16 INCHES
- 17.5 INCHES
- 19.5 INCHES
- 20 INCHES
- 20 AND 24 INCHES
- 19.5 AND 22.5 INCHES WIDEBASE
- 22.5 INCHES
- OFF-ROAD SIZES
- MICHELIN AGILIS 3 SIZES
- MICHELIN XCD2 SIZES

MICHELIN DIMENSIONAL DATA

22.5 INCHES

Table of inflation pressure (bar) in relation to maximum load per axle (kg)

Dimension	Tread pattern	Table of inflation pressure (bar) in relation to maximum load per axle (kg)																												
		psi	36	40	44	47	51	54	58	62	65	69	73	76	80	83	87	91	94	98	102	105	109	112	116	120	123	127	131	
		bar	2.50	2.75	3.00	3.25	3.50	3.75	4.00	4.25	4.50	4.75	5.00	5.25	5.50	5.75	6.00	6.25	6.50	6.75	7.00	7.25	7.50	7.75	8.00	8.25	8.50	8.75	9.00	
12R22.5	X LINE ENERGY Z	single													4800	4990	5180	5370	5560	5760	5950	6140	6330	6520	6720	6910	7100			
		dual														8780	9140	9490	9840	10190	10540	10890	11240	11590	11950	12300	12650	13000		
	X MULTI Z	single														4800	4990	5180	5370	5560	5760	5950	6140	6330	6520	6720	6910	7100		
		dual														8780	9140	9490	9840	10190	10540	10890	11240	11590	11950	12300	12650	13000		
	X WORKS XZY	single														4800	4990	5180	5370	5560	5760	5950	6140	6330	6520	6720	6910	7100		
		dual														8780	9140	9490	9840	10190	10540	10890	11240	11590	11950	12300	12650	13000		
	XZE2+	single														4800	4990	5180	5370	5560	5760	5950	6140	6330	6520	6720	6910	7100		
		dual														8780	9140	9490	9840	10190	10540	10890	11240	11590	11950	12300	12650	13000		
	XZY-2	single														4800	4990	5180	5370	5560	5760	5950	6140	6330	6520	6720	6910	7100		
		dual														8510	8850	9190	9540	9880	10220	10560	10900	11240	11580	11920	12260	12600		
	X WORKS XDY	single														4800	4990	5180	5370	5560	5760	5950	6140	6330	6520	6720	6910	7100		
		dual														8780	9140	9490	9840	10190	10540	10890	11240	11590	11950	12300	12650	13000		
	XDE2+	single														4800	4990	5180	5370	5560	5760	5950	6140	6330	6520	6720	6910	7100		
		dual														8780	9140	9490	9840	10190	10540	10890	11240	11590	11950	12300	12650	13000		
	XDE2+	single														4800	4990	5180	5370	5560	5760	5950	6140	6330	6520	6720	6910	7100		
		dual														8510	8850	9190	9540	9880	10220	10560	10900	11240	11580	11920	12260	12600		
	XDY 3	single														4800	4990	5180	5370	5560	5760	5950	6140	6330	6520	6720	6910	7100		
		dual														8510	8850	9190	9540	9880	10220	10560	10900	11240	11580	11920	12260	12600		

- 15-16 INCHES
- 17.5 INCHES
- 19.5 INCHES
- 20 INCHES
- 20 AND 24 INCHES
- 19.5 AND 22.5 INCHES WIDEBASE
- 22.5 INCHES
- OFF-ROAD SIZES
- MICHELIN AGILIS 3 SIZES
- MICHELIN XCD2 SIZES

Dimensional data for general indication only, for official data consult MICHELIN Technical Correspondent.

MICHELIN DIMENSIONAL DATA

22.5 INCHES

Dimension	Tread Pattern	Category	Type	PR (Ply Rating)	Load / Speed Index	Unique point (3)	Normal pressure for unique point (bar)	Original tread depth	Nominal load per axle (single) (kg)	Nominal pressure for load (single) (bar)	Nominal load per axle (dual) (kg)	Nominal pressure for load (dual) (bar)	Maximum section width in service (mm)	Maximum diameter in service (mm) (1)	Rolling circumference (mm)	Approved rim(s) ETRTO	Laden section width (mm) (2)	Free section width (mm) (2)	Diameter (mm) (2)	Static laden radius (mm) (2)	Rolling circumference (mm) (2)	Minimum dual spacing (mm) (2)	Recommended rim(s) by MICHELIN	Tube	Flap	Seal
13R22.5	X WORKS HD Z	3	TL	18	156/151K	158/152G	9.00	17.0	8000	8.75	13800	8.75	320	1158	3532	9.00 - 9.75	340	307	1122	523	3425	349	9.00			
	WORKS XZY	3	TL	18	156/150K			18.0	8000	8.75	13400	8.75	320	1158	3532	9.00 - 9.75	309	309	1122	520	3425	349	9.00			
	XZE 2	2	TL	18	156/150L			16.0	8000	8.50	13400	8.50	326	1146	3495	9.00 - 9.75	344	310	1122	519	3420	351	9.00			
	XZH2 R	3	TL	18	154/150G	156/150F	9.00	22.0	7500	8.00	13400	8.00	326	1146	3495	9.00 - 9.75	347	317	1135	528	3456	359	9.00			
	X WORKS HD D	3	TL	18	156/151K	158/152G	9.00	21.8	8000	8.75	13800	8.75	320	1158	3532	9.00 - 9.75	343	306	1129	524	3430	349	9.00			
	X WORKS XDY	3	TL	18	156/150K			22.5	8000	8.75	13400	8.75	320	1158	3532	9.00 - 9.75	341	308	1130	525	3430	349	9.00			
	XDY 3	3	TL	18	154/150K	156G	8.50	23.6	7500	8.00	13400	8.00	326	1146	3495	9.00 - 9.75	343	310	1136	527	3465	351	9.00			
295/60R22.5	XZA2 ENERGY	1	TL		150/147K	149/146L	8.50	12.5	6700	9.00	12300	9.00	304	940	2867	9.00 - 9.75	311	290	918	424	2800	330	9.00			
	XDA 2+ ENERGY	1	TL		150/147K	149/146L	9.00	18.2	6700	9.00	12300	9.00	304	940	2867	9.00 - 9.75	312	289	928	429	2830	330	9.00			
	X MULTIWAY XD	2	TL		150/147K	149/146L	9.00	18.2	6700	9.00	12300	9.00	304	948	2891	9.00 - 9.75	312	289	927	430	2809	330	9.00			

• (1) ETRTO rating (standard value, the ETRTO standard rim may be different to the rim recommended by MICHELIN). • (2) MICHELIN rating, value measured on rim recommended by MICHELIN. • (3) Unique point: load capacity/authorized additional speed pair Load variations according to speed do not apply to the unique point.

See the next table for the recommended inflation pressure

- 15-16 INCHES
- 17.5 INCHES
- 19.5 INCHES
- 20 INCHES
- 20 AND 24 INCHES
- 19.5 AND 22.5 INCHES WIDEBASE
- 22.5 INCHES
- OFF-ROAD SIZES
- MICHELIN AGILIS 3 SIZES
- MICHELIN XCD2 SIZES

MICHELIN DIMENSIONAL DATA

22.5 INCHES

Table of inflation pressure (bar) in relation to maximum load per axle (kg)

Dimension	Tread pattern	Table of inflation pressure (bar) in relation to maximum load per axle (kg)																													
		psi	36	40	44	47	51	54	58	62	65	69	73	76	80	83	87	91	94	98	102	105	109	112	116	120	123	127	131		
		bar	2.50	2.75	3.00	3.25	3.50	3.75	4.00	4.25	4.50	4.75	5.00	5.25	5.50	5.75	6.00	6.25	6.50	6.75	7.00	7.25	7.50	7.75	8.00	8.25	8.50	8.75	9.00		
13R22.5	X WORKS HD Z	single																5680	5890	6110	6320	6530	6740	6950	7160	7370	7580	7790	8000		
		dual																	9810	10170	10530	10890	11260	11620	11980	12350	12710	13070	13440	13800	
	WORKS XZY	single																	5680	5890	6110	6320	6530	6740	6950	7160	7370	7580	7790	8000	
		dual																	9520	9870	10230	10580	10930	11280	11640	11990	12340	12690	13050	13400	
	XZE 2	single																			6270	6485	6700	6920	7140	7350	7570	7780	8000		
		dual																	10500	10865	11230	11590	11950	12310	12680	13040	13400				
	XZH2 R	single											4930	5140	5360	5570	5790	6000	6210	6430	6640	6860	7070	7290	7500						
		dual											8810	9190	9570	9950	10340	10720	11100	11490	11870	12250	12630	13020	13400						
	X WORKS HD D	single																	5680	5890	6110	6320	6530	6740	6950	7160	7370	7580	7790	8000	
		dual																	9810	10170	10530	10890	11260	11620	11980	12350	12710	13070	13440	13800	
	X WORKS XDY	single																	5680	5890	6110	6320	6530	6740	6950	7160	7370	7580	7790	8000	
		dual																	9520	9870	10230	10580	10930	11280	11640	11990	12340	12690	13050	13400	
	XDY 3	single											4930	5140	5360	5570	5790	6000	6210	6430	6640	6860	7070	7290	7500						
		dual											8810	9190	9570	9950	10340	10720	11100	11490	11870	12250	12630	13020	13400						
295/60R22.5	XZA2 ENERGY	single																4640	4810	4980	5150	5330	5500	5670	5840	6010	6180	6360	6530	6700	
		dual																8520	8830	9150	9460	9780	10090	10410	10720	11040	11350	11670	11980	12300	
	XDA 2+ ENERGY	single																4640	4810	4980	5150	5330	5500	5670	5840	6010	6180	6360	6530	6700	
		dual																8520	8830	9150	9460	9780	10090	10410	10720	11040	11350	11670	11980	12300	
	X MULTIWAY XD	single																4640	4810	4980	5150	5330	5500	5670	5840	6010	6180	6360	6530	6700	
		dual																8520	8830	9150	9460	9780	10090	10410	10720	11040	11350	11670	11980	12300	

- 15-16 INCHES
- 17.5 INCHES
- 19.5 INCHES
- 20 INCHES
- 20 AND 24 INCHES
- 19.5 AND 22.5 INCHES WIDEBASE
- 22.5 INCHES
- OFF-ROAD SIZES
- MICHELIN AGILIS 3 SIZES
- MICHELIN XCD2 SIZES

Dimensional data for general indication only, for official data consult MICHELIN Technical Correspondent.

MICHELIN DIMENSIONAL DATA

22.5 INCHES

Dimension	Tread Pattern	Category	Type	PR (Ply Rating)	Load / Speed Index	Unique point (3)	Normal pressure for unique point (bar)	Original tread depth	Nominal load per axle (single) (kg)	Nominal pressure for load (single) (bar)	Nominal load per axle (dual) (kg)	Nominal pressure for load (dual) (bar)	Maximum section width in service (mm)	Maximum diameter in service (mm) (1)	Rolling circumference (mm)	Approved rim(s) ETRTO	Laden section width (mm) (2)	Free section width (mm) (2)	Diameter (mm) (2)	Static laden radius (mm) (2)	Rolling circumference (mm) (2)	Minimum dual spacing (mm) (2)	Recommended rim(s) by MICHELIN	Tube	Flap	Seal
315/60R22.5	XZA2 ENERGY	1	TL		152/148L		12.5	7100	9.00	12600	8.50	326	966	2946	9.00 - 9.75	335	314	952	441	2900	350	9.00				
	XDA 2+ ENERGY	1	TL		152/148L		19.0	7100	9.00	12600	8.50	326	966	2946	9.00 - 9.75	337	313	964	447	2940	350	9.00				
255/70R22.5	XZA	1	TL		140/137M	140L	8.50	13.0	5000	8.00	9200	8.00	265	944	2879	6.75 - 7.50 - 8.25	271	248	930	433	2841	281	6.75			
	XZE*	2	TL		LRH		14.3	5000	8.25	9200	8.25	265	944	2879	6.75 - 7.50 - 8.25	280	260	932	437	2856	295	7.50				
275/70R22.5	X MULTI Z	2	TL	18	148/145L	149/146K	9.00	14.0	6300	9.00	11600	9.00	287	974	2971	7.50 - 8.25	302	278	959	448	2942	311	7.50			
	X INCITY Z	5	TL	18	148/145J	152/148E		16.0	6300	9.00	11600	9.00	287	974	2971	7.50 - 8.25	299	276	962	448	2933	303	7.50			
	XZE2+	2	TL	18	148/145M			15.0	6300	9.00	11600	9.00	287	974	2971	7.50 - 8.25	299	276	966	448	2950	312	7.50			
	XJW4+	2	TL		148/145L			16.3	6300	9.00	11600	8.50	287	974	2971	7.50 - 8.25 - 9.00	298	276	969	450	2960	312	7.50			
	X MULTI D	2	TL	18	148/145L	149/146K	9.00	15.0	6300	9.00	11600	9.00	287	974	2971	7.50 - 8.25	298	274	958	446	2929	310	7.50			
	XDE2+	2	TL	16	148/145M			18.5	6300	9.00	11600	9.00	287	974	2971	7.50 - 8.25	299	275	973	454	2970	311	7.50			

• (1) ETRTO rating (standard value, the ETRTO standard rim may be different to the rim recommended by MICHELIN). • (2) MICHELIN rating, value measured on rim recommended by MICHELIN. • (3) Unique point: load capacity/authorized additional speed pair Load variations according to speed do not apply to the unique point.

See the next table for the recommended inflation pressure

- 15-16 INCHES
- 17.5 INCHES
- 19.5 INCHES
- 20 INCHES
- 20 AND 24 INCHES
- 19.5 AND 22.5 INCHES WIDEBASE
- 22.5 INCHES
- OFF-ROAD SIZES
- MICHELIN AGILIS 3 SIZES
- MICHELIN XCD2 SIZES

MICHELIN DIMENSIONAL DATA

22.5 INCHES

Table of inflation pressure (bar) in relation to maximum load per axle (kg)

Dimension	Tread pattern	Table of inflation pressure (bar) in relation to maximum load per axle (kg)																															
		psi	36	40	44	47	51	54	58	62	65	69	73	76	80	83	87	91	94	98	102	105	109	112	116	120	123	127	131				
		bar	2.50	2.75	3.00	3.25	3.50	3.75	4.00	4.25	4.50	4.75	5.00	5.25	5.50	5.75	6.00	6.25	6.50	6.75	7.00	7.25	7.50	7.75	8.00	8.25	8.50	8.75	9.00				
315/60R22.5	XZA2 ENERGY	single																		4920	5100	5280	5460	5640	5830	6010	6190	6370	6550	6740	6920	7100	
		dual																			9190	9540	9880	10220	10560	10900	11240	11580	11920	12260	12600		
	XDA 2+ ENERGY	single																			4920	5100	5280	5460	5640	5830	6010	6190	6370	6550	6740	6920	7100
		dual																			9190	9540	9880	10220	10560	10900	11240	11580	11920	12260	12600		
255/70R22.5	XZA	single											3290	3430	3570	3710	3860	4000	4140	4290	4430	4570	4710	4860	5000								
		dual											6050	6310	6570	6830	7100	7360	7620	7890	8150	8410	8670	8940	9200								
	XZE*	single													3800	3910	4020	4130	4240	4360	4480	4600	4700	4800	4900	5000							
		dual													7200	7400	7600	7800	8000	8120	8240	8360	8570	8780	8990	9200							
275/70R22.5	X MULTI Z	single																		4360	4520	4680	4850	5010	5170	5330	5490	5650	5820	5980	6140	6300	
		dual																			8030	8330	8630	8920	9220	9520	9820	10110	10410	10710	11010	11300	11600
	X INCITY Z	single																			4360	4520	4680	4850	5010	5170	5330	5490	5650	5820	5980	6140	6300
		dual																			8030	8330	8630	8920	9220	9520	9820	10110	10410	10710	11010	11300	11600
	XZE2+	single																			4360	4520	4680	4850	5010	5170	5330	5490	5650	5820	5980	6140	6300
		dual																			8030	8330	8630	8920	9220	9520	9820	10110	10410	10710	11010	11300	11600
	XJW4+	single																			4360	4520	4680	4850	5010	5170	5330	5490	5650	5820	5980	6140	6300
		dual													8030	8330	8630	8920	9220	9520	9820	10110	10410	10710	11010	11300	11600						
	X MULTI D	single																			4360	4520	4680	4850	5010	5170	5330	5490	5650	5820	5980	6140	6300
		dual																			8030	8330	8630	8920	9220	9520	9820	10110	10410	10710	11010	11300	11600
	XDE2+	single																			4360	4520	4680	4850	5010	5170	5330	5490	5650	5820	5980	6140	6300
		dual																			8030	8330	8630	8920	9220	9520	9820	10110	10410	10710	11010	11300	11600

- 15-16 INCHES
- 17.5 INCHES
- 19.5 INCHES
- 20 INCHES
- 20 AND 24 INCHES
- 19.5 AND 22.5 INCHES WIDEBASE
- 22.5 INCHES
- OFF-ROAD SIZES
- MICHELIN AGILIS 3 SIZES
- MICHELIN XCD2 SIZES

Dimensional data for general indication only, for official data consult MICHELIN Technical Correspondent.

MICHELIN DIMENSIONAL DATA

22.5 INCHES

Dimension	Tread Pattern	Category	Type	PR (Ply Rating)	Load / Speed Index	Unique point (3)	Normal pressure for unique point (bar)	Original tread depth	Nominal load per axle (single) (kg)	Nominal pressure for load (single) (bar)	Nominal load per axle (dual) (kg)	Nominal pressure for load (dual) (bar)	Maximum section width in service (mm)	Maximum diameter in service (mm) (1)	Rolling circumference (mm)	Approved rim(s) ETRTO	Laden section width (mm) (2)	Free section width (mm) (2)	Diameter (mm) (2)	Static laden radius (mm) (2)	Rolling circumference (mm) (2)	Minimum dual spacing (mm) (2)	Recommended rim(s) by MICHELIN	Tube	Flap	Seal
275/70R22.5	XDW ICE GRIP	2	TL		148/145L		19.0	6300	9.00	11600	8.50	287	974	2971	7.50 - 8.25	299	276	970	452	2970	311	7.50				
	X MULTI T	2	TL	18	148/145L	152/148J	14.0	6300	9.00	11600	9.00	287	974	2971	7.50 - 8.25	303	280	960	447	2943	311	7.50				
	XTA2 ENERGY	1	TL		152/148J		12.4	7100	9.00	12600	9.00	287	974	2971	7.50 - 8.25	298	271	954	440	2924	307	7.50				
	XTY2	3	TL	16	148/145J		17.0	6300	9.00	11600	8.50	287	974	2971	7.50 - 8.25	298	276	970	450	2960	312	7.50				
305/70R22.5	X MULTI Z	2	TL	20	152/150L		13.5	7100	9.00	13400	9.00	317	1018	3105	8.25 - 9.00	333	308	1010	471	3093	340	8.25				
	X INCITY Z	5	TL		153/150J		19.2	7100	9.00	13400	9.00	317	1018	3105	8.25 - 9.00			1003	468		341	8.25				
	XZA2 ENERGY	1	TL	16	152/148L	150/147M	8.50	12.5	7100	9.00	12600	9.00	317	1018	3105	8.25 - 9.00	324	300	995	460	3030	339	8.25			
	XZU2T	5	TL	16	150/147J	154/150E	8.75	17.5	6700	8.50	12300	8.00	317	1018	3105	8.25 - 9.00	327	302	1003	465	3060	342	8.25			
	XDA 2+ ENERGY	1	TL		152/148L	150/147M	8.50	16.0	7100	9.00	12600	9.00	309	1028	3135	8.25 - 9.00	325	299	1002	466	3064	340	8.25			
	XDE2+	2	TL		152/148L	150/147M	8.50	19.0	7100	9.00	12600	9.00	317	1018	3105	8.25 - 9.00	325	301	1006	467	3070	340	8.25			
	X MULTI HL Z	2	TL	20	154/150L	152/148M	9.00	14.3	7500	9.00	13400	9.00	317	1018	3105	8.25 - 9.00	328	308	998	462	3048	340	8.25			
	X MULTI D	2	TL		154/150L			18.5	7500	9.00	13400	9.00	317	1018	3105	8.25 - 9.00	326	299	1006	464	3061	340	8.25			
	X INCITY EV Z	5	TL	20	153/150J	156/150E	9.00	17.5	7300	9.00	13400	9.00	317	1018	3105	8.25 - 9.00	323	296	1008	466	3070	340	8.25			

• (1) ETRTO rating (standard value, the ETRTO standard rim may be different to the rim recommended by MICHELIN). • (2) MICHELIN rating, value measured on rim recommended by MICHELIN. • (3) Unique point: load capacity/authorized additional speed pair Load variations according to speed do not apply to the unique point.

See the next table for the recommended inflation pressure

Dimensional data for general indication only, for official data consult MICHELIN Technical Correspondent.

- 15-16 INCHES
- 17.5 INCHES
- 19.5 INCHES
- 20 INCHES
- 20 AND 24 INCHES
- 19.5 AND 22.5 INCHES WIDEBASE
- 22.5 INCHES
- OFF-ROAD SIZES
- MICHELIN AGILIS 3 SIZES
- MICHELIN XCD2 SIZES

MICHELIN DIMENSIONAL DATA

22.5 INCHES

Dimension	Tread Pattern	Category	Type	PR (Ply Rating)	Load / Speed Index	Unique point (3)	Normal pressure for unique point (bar)	Original tread depth	Nominal load per axle (single) (kg)	Nominal pressure for load (single) (bar)	Nominal load per axle (dual) (kg)	Nominal pressure for load (dual) (bar)	Maximum section width in service (mm)	Maximum diameter in service (mm) (1)	Rolling circumference (mm)	Approved rim(s) ETRTO	Laden section width (mm) (2)	Free section width (mm) (2)	Diameter (mm) (2)	Static laden radius (mm) (2)	Rolling circumference (mm) (2)	Minimum dual spacing (mm) (2)	Recommended rim(s) by MICHELIN	Tube	Flap	Seal
315/70R22.5	X MULTIWAY 3D XZE	2	TL		156/150L		14.2	8000	9.00	13400	9.00	318	1032	3148	9.00	345	317	1014	470	3099	350	9.00				
	X MULTIWAY 3D XDE	2	TL		154/150L		18.3	7500	9.00	13400	9.00	318	1040	3172	9.00	342	316	1020	476	3109	350	9.00				
	XDA 2+ ENERGY	1	TL		154/150L	152/148M	8.50	17.0	7500	9.00	13400	9.00	318	1032	3148	9.00 - 9.75	344	316	1020	474	3113	350	9.00			
	XDW ICE GRIP	2	TL		154/150L		16.3	7500	9.00	13400	9.00	318	1032	3148	9.00 - 9.75	339	318	1018	473	3110	350	9.00				
275/80R22.5	XZN+ MIX ENERGY	2	TL		151/148J	149/146L	9.00	14.6	6900	9.00	12600	9.00	276	1012	3087	7.50 - 8.25	306	278	1021	474	3117	315	7.50			
	XZN MIX ENERGY	2	TL		151/148J	149/146L	9.00	14.6	6900	9.00	12600	9.00	276	1012	3087	7.50 - 8.25	306	278	1021	474	3117	315	7.50			
	X INCITY XZU3	5	TL		149/146J	152/148E	8.75	17.5	6500	8.50	12000	8.50	287	1030	3142	7.50 - 8.25	306	278	1027	478	3138	315	7.50			
	XZE2+	2	TL	16	149/146L		15.5	6500	8.50	12000	8.50	287	1030	3142	7.50 - 8.25	307	280	1023	475	3120	317	7.50				
	XJE4 MIX ENERGY	1	TL		151/148J	149/146L	8.50	14.4	6900	9.00	12600	9.00	287	1030	3142	7.50 - 8.25 - 9.00	306	277	1021	474	3120	315	7.50			
	XDE2+	2	TL	16	149/146L		22.0	6500	8.50	12000	8.50	287	1030	3142	7.50 - 8.25	307	280	1036	481	3160	317	7.50				
	XDW ICE GRIP	2	TL		151/148J	149/146L	8.50	18.2	6900	9.00	12600	9.00	287	1030	3142	7.50 - 8.25 - 9.00	309	281	1029	478	3140	317	7.50			

• (1) ETRTO rating (standard value, the ETRTO standard rim may be different to the rim recommended by MICHELIN). • (2) MICHELIN rating, value measured on rim recommended by MICHELIN. • (3) Unique point: load capacity/authorized additional speed pair Load variations according to speed do not apply to the unique point.

See the next table for the recommended inflation pressure

Dimensional data for general indication only, for official data consult MICHELIN Technical Correspondent.

- 15-16 INCHES
- 17.5 INCHES
- 19.5 INCHES
- 20 INCHES
- 20 AND 24 INCHES
- 19.5 AND 22.5 INCHES WIDEBASE
- 22.5 INCHES
- OFF-ROAD SIZES
- MICHELIN AGILIS 3 SIZES
- MICHELIN XCD2 SIZES

MICHELIN DIMENSIONAL DATA

22.5 INCHES

Table of inflation pressure (bar) in relation to maximum load per axle (kg)

Dimension	Tread pattern		psi	36	40	44	47	51	54	58	62	65	69	73	76	80	83	87	91	94	98	102	105	109	112	116	120	123	127	131	
			bar	2.50	2.75	3.00	3.25	3.50	3.75	4.00	4.25	4.50	4.75	5.00	5.25	5.50	5.75	6.00	6.25	6.50	6.75	7.00	7.25	7.50	7.75	8.00	8.25	8.50	8.75	9.00	
			315/70R22.5	X MULTIWAY 3D XZE	single																5540	5740	5950	6150	6360	6560	6770	6970	7180	7380	7590
dual																			9280	9620	9960	10310	10650	10990	11340	11680	12030	12370	12710	13060	13400
X MULTIWAY 3D XDE	single																		5190	5380	5580	5770	5960	6150	6350	6540	6730	6920	7120	7310	7500
	dual																		9280	9620	9960	10310	10650	10990	11340	11680	12030	12370	12710	13060	13400
XDA 2+ ENERGY	single																		5190	5380	5580	5770	5960	6150	6350	6540	6730	6920	7120	7310	7500
	dual																		9280	9620	9960	10310	10650	10990	11340	11680	12030	12370	12710	13060	13400
XDW ICE GRIP	single																		5190	5380	5580	5770	5960	6150	6350	6540	6730	6920	7120	7310	7500
	dual																		9280	9620	9960	10310	10650	10990	11340	11680	12030	12370	12710	13060	13400
275/80R22.5	XZN+ MIX ENERGY	single																4780	4950	5130	5310	5480	5660	5840	6020	6190	6370	6550	6720	6900	
		dual																8720	9050	9370	9690	10020	10340	10660	10980	11310	11630	11950	12280	12600	
	XZN MIX ENERGY	single																4780	4950	5130	5310	5480	5660	5840	6020	6190	6370	6550	6720	6900	
		dual																8720	9050	9370	9690	10020	10340	10660	10980	11310	11630	11950	12280	12600	
	X INCITY XZU3	single														4390	4570	4740	4920	5090	5270	5450	5620	5800	5970	6150	6320	6500			
		dual														8110	8430	8760	9080	9410	9730	10050	10380	10700	11030	11350	11680	12000			
	XZE2+	single														4390	4570	4740	4920	5090	5270	5450	5620	5800	5970	6150	6320	6500			
		dual														8110	8430	8760	9080	9410	9730	10050	10380	10700	11030	11350	11680	12000			
	XJE4 MIX ENERGY	single																	4780	4950	5130	5310	5480	5660	5840	6020	6190	6370	6550	6720	6900
		dual																	8720	9050	9370	9690	10020	10340	10660	10980	11310	11630	11950	12280	12600
	XDE2+	single														4390	4570	4740	4920	5090	5270	5450	5620	5800	5970	6150	6320	6500			
		dual														8110	8430	8760	9080	9410	9730	10050	10380	10700	11030	11350	11680	12000			
	XDW ICE GRIP	single																	4780	4950	5130	5310	5480	5660	5840	6020	6190	6370	6550	6720	6900
		dual																	8720	9050	9370	9690	10020	10340	10660	10980	11310	11630	11950	12280	12600

- 15-16 INCHES
- 17.5 INCHES
- 19.5 INCHES
- 20 INCHES
- 20 AND 24 INCHES
- 19.5 AND 22.5 INCHES WIDEBASE
- 22.5 INCHES
- OFF-ROAD SIZES
- MICHELIN AGILIS 3 SIZES
- MICHELIN XCD2 SIZES

Dimensional data for general indication only, for official data consult MICHELIN Technical Correspondent.

MICHELIN DIMENSIONAL DATA

22.5 INCHES

Dimension	Tread Pattern	Category	Type	PR (Ply Rating)	Load / Speed Index	Unique point (3)	Normal pressure for unique point (bar)	Original tread depth	Nominal load per axle (single) (kg)	Nominal pressure for load (single) (bar)	Nominal load per axle (dual) (kg)	Nominal pressure for load (dual) (bar)	Maximum section width in service (mm)	Maximum diameter in service (mm) (1)	Rolling circumference (mm)	Approved rim(s) ETRTO	Laden section width (mm) (2)	Free section width (mm) (2)	Diameter (mm) (2)	Static laden radius (mm) (2)	Rolling circumference (mm) (2)	Minimum dual spacing (mm) (2)	Recommended rim(s) by MICHELIN	Tube	Flap	Seal
295/80R22.5	X LINE ENERGY Z	1	TL	18	152/149M	153/150J	8.50	14.0	7100	9.00	13000	9.00	310	1072	3270	8.25 - 9.00	324	296	1053	490	3225	326	8.25			
	X MULTI Z	2	TL	18	152/149M	153/150J	9.00	15.3	7100	9.00	13000	9.00	310	1072	3270	8.25 - 9.00	326	298	1055	492	3231	337	8.25			
	X MULTIWAY 3D XZE	2	TL		152/148L			15.2	7100	8.30	12600	8.00	310	1072	3270	8.25 - 9.00	328	297	1054	488	3221	326	8.25			
	X WORKS Z	3	TL	18	152/149K	154/150J	8.50	17.0	7100	8.50	13000	8.50	310	1112	3392	8.25 - 9.00	327	298	1060	493	3239	326	8.25			
	X COACH ENERGY Z	8	TL	18	152/149M	153/150J	8.50	14.1	6100	9.00	13000	9.00	310	1072	3270	8.25 - 9.00	324	297	1048	489	3232	326	8.25			
	X COACH HL Z	8	TL		154/149M			14.0	7500	8.50	13000	8.00	302	1062	3239	8.25	329	299	1055	488	3229	326	8.25			
	XZA 2+ ENERGY	1	TL	16	152/148M	153/150J	8.75	14.8	7100	8.50	12600	8.50	310	1062	3239	8.25 - 9.00	325	296	1057	490	3220	335	8.25			
	XZE2+	2	TL		152/148M			15.3	7100	8.50	12600	8.50	310	1062	3239	8.25 - 9.00	327	296	1057	490	3220	334	8.25			
	XZY-2	3	TL		152/148K			17.8	7100	8.50	12600	8.50	310	1112	3392	8.25 - 9.00	328	299	1060	492	3240	330	8.25			
	X INCITY XZU 3+	5	TL	16	152/148J	154/150E	8.75	18.0	7100	8.50	12600	8.50	310	1072	3270	8.25 - 9.00	328	297	1056	491	3225	336	8.25			
	XJW4+	2	TL		152/149L	153/150J	8.75	16.0	7100	8.50	13000	8.50	310	1112	3392	8.25 - 9.00	327	299	1054	489	3220	338	8.25			
	X MULTI Z2	2	TL	18	154/150L	152/149M	8.50	15.0	7500	8.50	13400	8.50	310	1062	3270	8.25 - 9.00	325	295.5	1045	484	3198	334	8.25			
	X INCITY Z	5	TL	16	154/149J			16.5	7500	8.50	13000	8.50	310	1062	3270	8.25 - 9.00	338	307	1048	484	3194		8.25			

• (1) ETRTO rating (standard value, the ETRTO standard rim may be different to the rim recommended by MICHELIN). • (2) MICHELIN rating, value measured on rim recommended by MICHELIN. • (3) Unique point: load capacity/authorized additional speed pair Load variations according to speed do not apply to the unique point.

See the next table for the recommended inflation pressure

Dimensional data for general indication only, for official data consult MICHELIN Technical Correspondent.

- 15-16 INCHES
- 17.5 INCHES
- 19.5 INCHES
- 20 INCHES
- 20 AND 24 INCHES
- 19.5 AND 22.5 INCHES WIDEBASE
- 22.5 INCHES
- OFF-ROAD SIZES
- MICHELIN AGILIS 3 SIZES
- MICHELIN XCD2 SIZES

MICHELIN DIMENSIONAL DATA

22.5 INCHES

Table of inflation pressure (bar) in relation to maximum load per axle (kg)

Dimension	Tread pattern	Table of inflation pressure (bar) in relation to maximum load per axle (kg)																																
		psi	36	40	44	47	51	54	58	62	65	69	73	76	80	83	87	91	94	98	102	105	109	112	116	120	123	127	131					
		bar	2.50	2.75	3.00	3.25	3.50	3.75	4.00	4.25	4.50	4.75	5.00	5.25	5.50	5.75	6.00	6.25	6.50	6.75	7.00	7.25	7.50	7.75	8.00	8.25	8.50	8.75	9.00					
295/80R22.5	X LINE ENERGY Z	single																			4920	5100	5280	5460	5640	5830	6010	6190	6370	6550	6740	6920	7100	
		dual																				9000	9330	9670	10000	10330	10670	11000	11330	11670	12000	12330	12670	13000
	X MULTI Z	single																				4920	5100	5280	5460	5640	5830	6010	6190	6370	6550	6740	6920	7100
		dual																				9000	9330	9670	10000	10330	10670	11000	11330	11670	12000	12330	12670	13000
	X MULTIWAY 3D XZE	single																				5300	5490	5690	5880	6080	6280	6470	6670	6860	7060			
		dual																				9720	10080	10440	10800	11160	11520	11880	12240	12600				
	X WORKS Z	single													4800	4990	5180	5370	5560	5760	5950	6140	6330	6520	6720	6910	7100							
		dual													8780	9140	9490	9840	10190	10540	10890	11240	11590	11950	12300	12650	13000							
	X COACH ENERGY Z	single																				4920	5100	5280	5460	5640	5830	6010	6190	6370	6550	6740	6920	7100
		dual																				9000	9330	9670	10000	10330	10670	11000	11330	11670	12000	12330	12670	13000
	X COACH HL Z	single											4770	4970	5180	5390	5590	5800	6010	6220	6420	6630	6840	7040	7250	7460								
		dual											8540	8910	9290	9660	10030	10400	10770	11140	11510	11890	12260	12630	13000									
	XZA 2+ ENERGY	single													4800	4990	5180	5370	5560	5760	5950	6140	6330	6520	6720	6910	7100							
		dual													8510	8850	9190	9540	9880	10220	10560	10900	11240	11580	11920	12260	12600							
	XZE2+	single													4800	4990	5180	5370	5560	5760	5950	6140	6330	6520	6720	6910	7100							
		dual													8510	8850	9190	9540	9880	10220	10560	10900	11240	11580	11920	12260	12600							
	XZY-2	single													4800	4990	5180	5370	5560	5760	5950	6140	6330	6520	6720	6910	7100							
		dual													8510	8850	9190	9540	9880	10220	10560	10900	11240	11580	11920	12260	12600							
	X INCITY XZU 3+	single													4800	4990	5180	5370	5560	5760	5950	6140	6330	6520	6720	6910	7100							
		dual													8510	8850	9190	9540	9880	10220	10560	10900	11240	11580	11920	12260	12600							
XJW4+	single																				5180	5370	5560	5760	5950	6140	6330	6520	6720	6910	7100			
	dual																				9490	9840	10190	10540	10890	11240	11590	11950	12300	12650	13000			
X MULTI Z2	single																				5500	5670	5850	6040	6250	6450	6660	6870	7080	7290	7500			
	dual																				9710	10080	10500	10910	11280	11640	12000	12350	12700	13050	13400			
X INCITY Z	single											4600	4840	5080	5280	5500	5660	5840	6040	6240	6440	6660	6860	7080	7280	7500								
	dual											8120	8400	8720	9040	9400	9760	10120	10480	10840	11200	11560	11920	12280	12640	13000								

- 15-16 INCHES
- 17.5 INCHES
- 19.5 INCHES
- 20 INCHES
- 20 AND 24 INCHES
- 19.5 AND 22.5 INCHES WIDEBASE
- 22.5 INCHES
- OFF-ROAD SIZES
- MICHELIN AGILIS 3 SIZES
- MICHELIN XCD2 SIZES

Dimensional data for general indication only, for official data consult MICHELIN Technical Correspondent.

MICHELIN DIMENSIONAL DATA

22.5 INCHES

Dimension	Tread Pattern	Category	Type	PR (Ply Rating)	Load / Speed Index	Unique point (3)	Normal pressure for unique point (bar)	Original tread depth	Nominal load per axle (single) (kg)	Nominal pressure for load (single) (bar)	Nominal load per axle (dual) (kg)	Nominal pressure for load (dual) (bar)	Maximum section width in service (mm)	Maximum diameter in service (mm) (1)	Rolling circumference (mm)	Approved rim(s) ETRTO	Laden section width (mm) (2)	Free section width (mm) (2)	Diameter (mm) (2)	Static laden radius (mm) (2)	Rolling circumference (mm) (2)	Minimum dual spacing (mm) (2)	Recommended rim(s) by MICHELIN	Tube	Flap	Seal
295/80R22.5	XJS WINTER GRIP+	2	TL		151/148J	149/146L	8.50	19.4	6900	9.00	12600	9.00	290	1030	3142	7.50- 8.25 - 9.00	306	279	1030	479	3128	316	7.50			
	XJS WINTER GRIP	2	TL	16	152/149L	153/150J		18.5	7100	8.50	13000	8.50	310	1112	3392	8.25 - 9.00	329	299	1064	495	3250	338	8.25			
	X MULTI D	2	TL	18	152/149M			18.7	7100	8.50	13000	8.50	310	1072	3270	8.25 - 9.00	327	297	1061	493	3225	326	8.25			
	X MULTIWAY 3D XDE	2	TL		152/148L			19.0	7100	8.30	12600	8.00	310	1062	3239	8.25 - 9.00	328	297	1061	492	3228	326	8.25			
	X COACH XD	8	TL		152/148M	154L	8.50	19.4	7100	8.50	13320	8.50	302	1073	3273	8.25	329	300	1062	494	3223	330	8.25			
	XDA 2+ ENERGY	1	TL		152/148M			16.8	7100	8.50	12600	8.50	310	1073	3273	8.25 - 9.00	327	300	1055	491	3215	330	8.25			
	XDE2+	2	TL		152/148M			23.0	7100	8.50	12600	8.50	310	1112	3392	8.25 - 9.00	328	300	1070	497	3270	330	8.25			
	XDW ICE GRIP	2	TL		152/149L	153/150J	8.75	19.7	7100	8.50	13000	8.50	310	1112	3392	8.25 - 9.00	329	300	1066	496	3260	330	8.25			
	X MULTI D+	2	TL	18	152/149M			20.0	7100	8.30	13000	8.30	310	1072	3270	8.25 - 9.00	329	298	1064	493	3340	337	8.25			
315/80R22.5	X MULTI ENERGY Z	2	TL		156/151L			15.5	8000	8.50	13800	8.25	318	1096	3343	9.00 - 9.75							9.00			
	X MULTIWAY 3D XZE	2	TL		156/150L	154/150M	8.00	16.5	8000	8.50	13400	8.00	318	1096	3343	9.00 - 9.75	347	316	1081	501	3302	350	9.00			

• (1) ETRTO rating (standard value, the ETRTO standard rim may be different to the rim recommended by MICHELIN). • (2) MICHELIN rating, value measured on rim recommended by MICHELIN. • (3) Unique point: load capacity/authorized additional speed pair Load variations according to speed do not apply to the unique point.

See the next table for the recommended inflation pressure

Dimensional data for general indication only, for official data consult MICHELIN Technical Correspondent.

- 15-16 INCHES
- 17.5 INCHES
- 19.5 INCHES
- 20 INCHES
- 20 AND 24 INCHES
- 19.5 AND 22.5 INCHES WIDEBASE
- 22.5 INCHES
- OFF-ROAD SIZES
- MICHELIN AGILIS 3 SIZES
- MICHELIN XCD2 SIZES

MICHELIN DIMENSIONAL DATA

22.5 INCHES

Table of inflation pressure (bar) in relation to maximum load per axle (kg)

Dimension	Tread pattern		psi	36	40	44	47	51	54	58	62	65	69	73	76	80	83	87	91	94	98	102	105	109	112	116	120	123	127	131	
			bar	2.50	2.75	3.00	3.25	3.50	3.75	4.00	4.25	4.50	4.75	5.00	5.25	5.50	5.75	6.00	6.25	6.50	6.75	7.00	7.25	7.50	7.75	8.00	8.25	8.50	8.75	9.00	
			295/80R22.5	XJS WINTER GRIP+	single																4780	4950	5130	5310	5480	5660	5840	6020	6190	6370	6550
		dual																8720	9050	9370	9690	10020	10340	10660	10980	11310	11630	11950	12280	12600	
	XJS WINTER GRIP	single																													
		dual																													
	X MULTI D	single														4800	4990	5180	5370	5560	5760	5950	6140	6330	6520	6720	6910	7100			
		dual														8780	9140	9490	9840	10190	10540	10890	11240	11590	11950	12300	12650	13000			
	X MULTIWAY 3D XDE	single																5300	5490	5690	5880	6080	6280	6470	6670	6860	7060				
		dual																9720	10080	10440	10800	11160	11520	11880	12240	12600					
	X COACH XD	single																5180	5370	5560	5760	5950	6140	6330	6520	6720	6910	7100			
		dual																9190	9540	9880	10220	10560	10900	11240	11580	11920	12260	12600			
	XDA 2+ ENERGY	single														4800	4990	5180	5370	5560	5760	5950	6140	6330	6520	6720	6910	7100			
		dual														8510	8850	9190	9540	9880	10220	10560	10900	11240	11580	11920	12260	12600			
	XDE2+	single														4800	4990	5180	5370	5560	5760	5950	6140	6330	6520	6720	6910	7100			
		dual														8510	8850	9190	9540	9880	10220	10560	10900	11240	11580	11920	12260	12600			
	XDW ICE GRIP	single																5180	5370	5560	5760	5950	6140	6330	6520	6720	6910	7100			
		dual																9490	9840	10190	10540	10890	11240	11590	11950	12300	12650	13000			
	X MULTI D+	single											4520	4700	4800	4990	5180	5370	5560	5760	5950	6140	6330	6520	6720	6910	7100				
		dual											8280	8640	8780	9140	9490	9840	10190	10540	10890	11240	11590	11950	12300	12650	13000				
315/80R22.5	X MULTI ENERGY Z	single														5410	5620	5840	6050	6270	6490	6700	6920	7140	7350	7570	7780	8000			
		dual														9580	9970	10350	10730	11120	11500	11880	12270	12650	13030	13420	13800				
	X MULTIWAY 3D XZE	single																5840	6050	6270	6490	6700	6920	7140	7350	7570	7780	8000			
		dual																10340	10720	11100	11490	11870	12250	12630	13020	13400					

- 15-16 INCHES
- 17.5 INCHES
- 19.5 INCHES
- 20 INCHES
- 20 AND 24 INCHES
- 19.5 AND 22.5 INCHES WIDEBASE
- 22.5 INCHES
- OFF-ROAD SIZES
- MICHELIN AGILIS 3 SIZES
- MICHELIN XCD2 SIZES

Dimensional data for general indication only, for official data consult MICHELIN Technical Correspondent.

MICHELIN DIMENSIONAL DATA

22.5 INCHES

Dimension	Tread Pattern	Category	Type	PR (Ply Rating)	Load / Speed Index	Unique point (3)	Normal pressure for unique point (bar)	Original tread depth	Nominal load per axle (single) (kg)	Nominal pressure for load (single) (bar)	Nominal load per axle (dual) (kg)	Nominal pressure for load (dual) (bar)	Maximum section width in service (mm)	Maximum diameter in service (mm) (1)	Rolling circumference (mm)	Approved rim(s) ETRTO	Laden section width (mm) (2)	Free section width (mm) (2)	Diameter (mm) (2)	Static laden radius (mm) (2)	Rolling circumference (mm) (2)	Minimum dual spacing (mm) (2)	Recommended rim(s) by MICHELIN	Tube	Flap	Seal
315/80R22.5	X WORKS XZY	3	TL		156/150K		16.0	8000	8.50	13400	8.50	318	1096	3343	9.00 - 9.75	348	317	1080	502	3308	350	9.00				
	X MULTIWAY XZE R	2	TL	18	156/151L	154/150M	8.50	13.9	8000	8.50	13800	8.30	318	1096	3343	9.00 - 9.75	347	316	1077	499	3300	358	9.00			
	XZA 2+ ENERGY	1	TL	18	156/151L	154/150M	8.50	15.9	8000	8.50	13800	8.30	318	1106	3373	9.00 - 9.75	345	314	1079	499	3306	355	9.00			
	X MULTIWAY 3D XDE	2	TL		156/150L	154/150M	8.00	19.2	8000	8.50	13400	8.00	318	1106	3373	9.00 - 9.75	349	318	1087	504	3303	350	9.00			
	X WORKS XDY	3	TL		156/150K		22.0	8000	8.50	13400	8.50	318	1096	3343	9.00 - 9.75	348	317	1091	507	3312	350	9.00				
	XDE2+	2	TL		156/150L	154/150M	8.00	23.5	8000	8.50	13400	8.50	318	1107	3376	9.00 - 9.75	347	318	1095	507	3320	350	9.00			
	XDW ICE GRIP	2	TL		156/150L		20.2	8000	8.50	13400	8.00	318	1096	3343	9.00 - 9.75	348	315	1090	504	3320	350	9.00				
	X Works HD Z	3	TL		156/150K		16.0	8000	8.50	13400	8.50	318	1096	3343	9.00 - 9.75	348	317	1080	502	3308	350	9.00				
	X Works HD D	3	TL		156/150K		22.0	8000	8.50	13400	8.50	318	1096	3343	9.00 - 9.75	348	317	1091	507	3312	350	9.00				

• (1) ETRTO rating (standard value, the ETRTO standard rim may be different to the rim recommended by MICHELIN). • (2) MICHELIN rating, value measured on rim recommended by MICHELIN. • (3) Unique point: load capacity/authorized additional speed pair Load variations according to speed do not apply to the unique point.

See the next table for the recommended inflation pressure

- 15-16 INCHES
- 17.5 INCHES
- 19.5 INCHES
- 20 INCHES
- 20 AND 24 INCHES
- 19.5 AND 22.5 INCHES WIDEBASE
- 22.5 INCHES
- OFF-ROAD SIZES
- MICHELIN AGILIS 3 SIZES
- MICHELIN XCD2 SIZES

MICHELIN DIMENSIONAL DATA

22.5 INCHES

Table of inflation pressure (bar) in relation to maximum load per axle (kg)

Dimension	Tread pattern	Table of inflation pressure (bar) in relation to maximum load per axle (kg)																													
		psi	36	40	44	47	51	54	58	62	65	69	73	76	80	83	87	91	94	98	102	105	109	112	116	120	123	127	131		
		bar	2.50	2.75	3.00	3.25	3.50	3.75	4.00	4.25	4.50	4.75	5.00	5.25	5.50	5.75	6.00	6.25	6.50	6.75	7.00	7.25	7.50	7.75	8.00	8.25	8.50	8.75	9.00		
315/80R22.5	X WORKS XZY	single																5840	6050	6270	6490	6700	6920	7140	7350	7570	7780	8000			
		dual																	9780	10140	10500	10860	11230	11590	11950	12310	12680	13040	13400		
	X MULTIWAY XZE R	single														5410	5620	5840	6050	6270	6490	6700	6920	7140	7350	7570	7780	8000			
		dual														9580	9970	10350	10730	11120	11500	11880	12270	12650	13030	13420	13800				
	XZA 2+ ENERGY	single														5410	5620	5840	6050	6270	6490	6700	6920	7140	7350	7570	7780	8000			
		dual														9860	10250	10650	11040	11430	11830	12220	12620	13010	13410	13800					
	X MULTIWAY 3D XDE	single																	5840	6050	6270	6490	6700	6920	7140	7350	7570	7780	8000		
		dual																	10340	10720	11100	11490	11870	12250	12630	13020	13400				
	X WORKS XDY	single																	5840	6050	6270	6490	6700	6920	7140	7350	7570	7780	8000		
		dual																	9780	10140	10500	10860	11230	11590	11950	12310	12680	13040	13400		
	XDE2+	single																	5840	6050	6270	6490	6700	6920	7140	7350	7570	7780	8000		
		dual																	10340	10720	11100	11490	11870	12250	12630	13020	13400				
	XDW ICE GRIP	single														5410	5620	5840	6050	6270	6490	6700	6920	7140	7350	7570	7780	8000			
		dual														9570	9950	10340	10720	11100	11490	11870	12250	12630	13020	13400					
	X Works HD Z	single																	5840	6050	6270	6490	6700	6920	7140	7350	7570	7780	8000		
		dual																	9780	10140	10500	10860	11230	11590	11950	12310	12680	13040	13400		
X Works HD D	single																	5840	6050	6270	6490	6700	6920	7140	7350	7570	7780	8000			
	dual																	9780	10140	10500	10860	11230	11590	11950	12310	12680	13040	13400			

- 15-16 INCHES
- 17.5 INCHES
- 19.5 INCHES
- 20 INCHES
- 20 AND 24 INCHES
- 19.5 AND 22.5 INCHES WIDEBASE
- 22.5 INCHES
- OFF-ROAD SIZES
- MICHELIN AGILIS 3 SIZES
- MICHELIN XCD2 SIZES

Dimensional data for general indication only, for official data consult MICHELIN Technical Correspondent.

MICHELIN DIMENSIONAL DATA

OFF-ROAD SIZES

Dimension	Tread Pattern	Category	Type	PR (Ply Rating)	Load / Speed Index	Unique point (3)	Normal pressure for unique point (bar)	Original tread depth	Nominal load per axle (single) (kg)	Nominal pressure for load (single) (bar)	Nominal load per axle (dual) (kg)	Nominal pressure for load (dual) (bar)	Maximum section width in service (mm)	Maximum diameter in service (mm) (1)	Rolling circumference (mm)	Approved rim(s) ETRTO	Laden section width (mm) (2)	Free section width (mm) (2)	Diameter (mm) (2)	Static laden radius (mm) (2)	Rolling circumference (mm) (2)	Minimum dual spacing (mm) (2)	Recommended rim(s) by MICHELIN	Tube	Flap	Seal
325/85R16	XML	4	TL		137J	134K	4.50	16.5	4600	4.50		4.50	338	992		9.0	364	327	984	449	2980		9.0			Jt 1967
255/100R16	XZL	4	TL		126K	134J	5.75	16.5	3400	4.50			260	946		16-6.00 G	286	255	923	426	2810		16-6.50 H			Jt 1967
275/80R20	XZL	4	TL	8	128K			15.2	3600	4.20			289	974		9 - W9 - 9 SDC	305	280	939	431	2850		9	20 P	230-20LB / 20x8.50	
335/80R20	XZL	4	TL	16	141K			17.8	5150	4.30						9-W9-9 SDC-W10 DW10-11-11 SDC-W11 DW11-12-12 SDC	381	345	1037	473	3140		11	20 P	310-20LB / 20x10.00	Jt 1681
365/80R20	XZL	4	TL		152K			19.9	7100	6.00						11-11 SDC-12-12 SDC	410	372	1096	501	3330		11	20 Q	310-20LB / 20x10.00	Jt 1443
475/80R20	XML	4	TL		166G			23.5	10600	6.00						14.0V5°	526	480	1272	581	3859		14.0V			
365/85R20	XZL	4	TL		164G			22.5	10000	7.50						10.0-10.00V-10.00W	411	368	1144	520	3460		20-10.00 W	20 S	280-20 L	
395/85R20	XZL 2	4	TL		168K	164L	8.50	20.0	11200	8.50			401	1220			429	388	1176	534	3584		20-10,00 W			
	XZL	4	TL		168G	161J	8.50	25.8	11200	8.50						10.0-10.00V-10.00W	425	388	1189	542	3600		20-10.00 W	20 S	280-20L	Jt 1443
9.00R20	XL	4	TT		140/137K			17.0	5000	7.00	9200	7.00	268	1038		6.0-6.00T-6.5-B6.5-7.0 B7.0-7.33V-7.5-B7.5	278	252	1032	479	3148	285	7.0	20 M	200-20L / 20x7.50	

• (1) ETRTO rating (standard value, the ETRTO standard rim may be different to the rim recommended by MICHELIN). • (2) MICHELIN rating, value measured on rim recommended by MICHELIN. • (3) Unique point: load capacity/authorized additional speed pair Load variations according to speed do not apply to the unique point.

See the next table for the recommended inflation pressure

- 15-16 INCHES
- 17.5 INCHES
- 19.5 INCHES
- 20 INCHES
- 20 AND 24 INCHES
- 19.5 AND 22.5 INCHES WIDEBASE
- 22.5 INCHES
- OFF-ROAD SIZES
- MICHELIN AGILIS 3 SIZES
- MICHELIN XCD2 SIZES

MICHELIN DIMENSIONAL DATA

OFF-ROAD SIZES

Table of inflation pressure (bar) in relation to maximum load per axle (kg)

Dimension	Tread pattern	psi	36	40	44	47	51	54	58	62	65	69	73	76	80	83	87	91	94	98	102	105	109	112	116	120	123	127	131	134
		bar	2.50	2.75	3.00	3.25	3.50	3.75	4.00	4.25	4.50	4.75	5.00	5.25	5.50	5.75	6.00	6.25	6.50	6.75	7.00	7.25	7.50	7.75	8.00	8.25	8.50	8.75	9.00	9.25
		325/85R16	XML	single			3290	3500	3720	3940	4160	4380	4600																	
		dual			-	-	-	-	-	-	-																			
255/100R16	XZL	single			2430	2590	2750	2910	3080	3240	3400																			
		dual			-	-	-	-	-	-	-																			
275/80R20	XZL	single			2730	2910	3090	3270	3435	3600																				
		dual			-	-	-	-	-	-	-																			
335/80R20	XZL	single	For Pressure, Please Consult MICHELIN's Representatives																											
		dual			-	-	-	-	-	-	-																			
365/80R20	XZL	single											6500	6700	6900	7100														
		dual											-	-	-	-														
475/80R20	XML	single			5890	6280	6670	7070	7460	7850	8240	8640	9030	9420	9810	10210	10600													
		dual			-	-	-	-	-	-	-	-	-	-	-	-	-													
365/85R20	XZL	single											6970	7270	7580	7880	8180	8480	8790	9090	9390	9700	10000							
		dual											-	-	-	-	-	-	-	-	-	-	-							
395/85R20	XZL 2	single															8170	8480	8780	9080	9380	9690	9990	10290	10590	10900	11200			
		dual															-	-	-	-	-	-	-	-	-	-	-	-	-	-
9.00R20	XZL	single															8170	8480	8780	9080	9380	9690	9990	10290	10590	10900	11200			
		dual															-	-	-	-	-	-	-	-	-	-	-	-	-	-
9.00R20	XL	single							3060	3230	3390	3550	3710	3870	4030	4190	4350	4520	4680	4840	5000									
		dual							5640	5940	6230	6530	6830	7120	7420	7720	8010	8310	8610	8900	9200									

- 15-16 INCHES
- 17.5 INCHES
- 19.5 INCHES
- 20 INCHES
- 20 AND 24 INCHES
- 19.5 AND 22.5 INCHES WIDEBASE
- 22.5 INCHES
- OFF-ROAD SIZES
- MICHELIN AGILIS 3 SIZES
- MICHELIN XCD2 SIZES

Dimensional data for general indication only, for official data consult MICHELIN Technical Correspondent.

MICHELIN DIMENSIONAL DATA

OFF-ROAD SIZES

Dimension	Tread Pattern	Category	Type	PR (Ply Rating)	Load / Speed Index	Unique point (3)	Normal pressure for unique point (bar)	Original tread depth	Nominal load per axle (single) (kg)	Nominal pressure for load (single) (bar)	Nominal load per axle (dual) (kg)	Nominal pressure for load (dual) (bar)	Maximum section width in service (mm)	Maximum diameter in service (mm) (1)	Rolling circumference (mm)	Approved rim(s) ETRTO	Laden section width (mm) (2)	Free section width (mm) (2)	Diameter (mm) (2)	Static laden radius (mm) (2)	Rolling circumference (mm) (2)	Minimum dual spacing (mm) (2)	Recommended rim(s) by MICHELIN	Tube	Flap	Seal
11.00R20	XZL	4	TL	16	150/146K			18.0	6700	8.00	12000	8.00	297	1104		7.33V-7.5-B7.5-8.0 8.0V-B8.0-8.5 8.50V-B8.5-9.00V	330	299	1092	508	3340	338	8.0	20 P	20x8.50MI	
12.00R20	XZL	4	TL	18	154/149K			18.7	7500	8.50	13000	8.50	319	1146		7.33V-8.0-8.0V-B8.0 8.5-8.50V-B8.5 9.0-9.00V	344	311	1131	527	3460	352	8.5	20 Q	230-20LB / 20x8.50	
	XML	4	TL	18	149/146J			19.5	6500	7.20	12000	7.20	319	1158		7.33V-8.0-8.0V B8.0-8.5-8.50V B8.5-9.0-9.00V	339	308	1131	526	3443	349	8.5	20 Q		
14.00R20	XML	4	TL		153G	149K	6.20	24.4	7300	6.20			377	1268		9.0-10.0-10.00V 10.00W	421	383	1258	581	3830		10.00W			
	XZL+	4	TL		164/161J	166G	7.90	22.3	10000	7.80	18500	7.80					428	386	1258	578	3832	436	20-10,00W			
	XZL+	4	TL	22	164/160J	166G	7.90	22.3	10000	7.60	18000	7.60					428	386	1258	578	3832	436	20-10,00W			
	XZL	4	TL	22	164/160G	156J	7.60	23.3	10000	7.60	16000	7.60	384	1258		9.0-9.00V-10.0 10.00V-10.00W	427	384	1258	579	3826	434	10.00			
	XS	4	TL		160/157F			16.5	9000	7.00	16500	7.00	377	1282		9.0-10.0-10.00V 10.00W	410	369	1238	566	3772	417	10.00W			
16.00R20	XZL	4	TL		173/170G			27.0	13000	7.50	24000	7.50	482	1413			488	438	1343	609	4090	495	10.00W	20 V	310-20LB / 20x10.00	

• (1) ETRTO rating (standard value, the ETRTO standard rim may be different to the rim recommended by MICHELIN). • (2) MICHELIN rating, value measured on rim recommended by MICHELIN. • (3) Unique point: load capacity/authorized additional speed pair Load variations according to speed do not apply to the unique point.

See the next table for the recommended inflation pressure

- 15-16 INCHES
- 17.5 INCHES
- 19.5 INCHES
- 20 INCHES
- 20 AND 24 INCHES
- 19.5 AND 22.5 INCHES WIDEBASE
- 22.5 INCHES
- OFF-ROAD SIZES
- MICHELIN AGILIS 3 SIZES
- MICHELIN XCD2 SIZES

MICHELIN DIMENSIONAL DATA

OFF-ROAD SIZES

Table of inflation pressure (bar) in relation to maximum load per axle (kg)

Dimension	Tread pattern	Table of inflation pressure (bar) in relation to maximum load per axle (kg)																													
		psi	36	40	44	47	51	54	58	62	65	69	73	76	80	83	87	91	94	98	102	105	109	112	116	120	123	127	131	134	
		bar	2.50	2.75	3.00	3.25	3.50	3.75	4.00	4.25	4.50	4.75	5.00	5.25	5.50	5.75	6.00	6.25	6.50	6.75	7.00	7.25	7.50	7.75	8.00	8.25	8.50	8.75	9.00	9.25	
11.00R20	XZL	single				3000	3250	3500	3670	3830	4000	4200	4400	4590	4770	4960	5140	5330	5510	5700	5900	6100	6300	6500	6700						
		dual				5800	6100	6400	6670	6930	7200	7500	7800	8170	8540	8910	9290	9660	10030	10400	10720	11040	11360	11680	12000						
12.00R20	XZL	single										4500	4690	4880	5070	5270	5470	5680	5880	6080	6280	6490	6690	6890	7090	7300	7500				
		dual										7800	8130	8450	8780	9140	9490	9840	10190	10540	10890	11240	11590	11950	12300	12650	13000				
	XML	single							4090	4290	4500	4700	4910	5110	5310	5520	5720	5930	6130	6340											
		dual							7550	7920	8300	8680	9060	9430	9810	10190	10570	10940	11320	11700											
14.00R20	XML	single				4200	4460	4730	4990	5250	5510	5780	6040	6300	6560	6830	7300														
		dual				-	-	-	-	-	-	-	-	-	-	-	-														
	XZL+	single											6890	7190	7490	7780	8080	8380	8680	8980	9280	9580	9880	10000							
		dual											12400	12930	13470	14010	14550	15090	15630	16170	16710	17250	17780	18500							
	XZL+	single											6890	7190	7490	7780	8080	8380	8680	8980	9280	9580	9880	10000							
		dual											12400	12930	13470	14010	14550	15090	15630	16170	16710	17250	17780	18000							
	XZL	single									6290	6590	6890	7190	7490	7780	8080	8380	8680	8980	9280	9580	9880								
		dual									11320	11860	12400	12930	13470	14010	14550	15090	15630	16170	16710	17250	17780								
XS	single							5520	5810	6100	6390	6680	6970	7260	7550	7840	8130	8420	8710	9000											
	dual							10110	10650	11180	11710	12240	12770	13310	13840	14370	14900	15440	15970	16500											
16.00R20	XZL	single								8300	8690	9090	9490	9880	10280	10670	11070	11460	11860	12250	12650	13000									
		dual									15810	16530	17250	17960	18680	19400	20120	20840	21560	22280	22990	24000									

- 15-16 INCHES
- 17.5 INCHES
- 19.5 INCHES
- 20 INCHES
- 20 AND 24 INCHES
- 19.5 AND 22.5 INCHES WIDEBASE
- 22.5 INCHES
- OFF-ROAD SIZES
- MICHELIN AGILIS 3 SIZES
- MICHELIN XCD2 SIZES

Dimensional data for general indication only, for official data consult MICHELIN Technical Correspondent.

MICHELIN DIMENSIONAL DATA

OFF-ROAD SIZES

Dimension	Tread Pattern	Category	Type	PR (Ply Rating)	Load / Speed Index	Unique point (3)	Normal pressure for unique point (bar)	Original tread depth	Nominal load per axle (single) (kg)	Nominal pressure for load (single) (bar)	Nominal load per axle (dual) (kg)	Nominal pressure for load (dual) (bar)	Maximum section width in service (mm)	Maximum diameter in service (mm) (1)	Rolling circumference (mm)	Approved rim(s) ETRTO	Laden section width (mm) (2)	Free section width (mm) (2)	Diameter (mm) (2)	Static laden radius (mm) (2)	Rolling circumference (mm) (2)	Minimum dual spacing (mm) (2)	Recommended rim(s) by MICHELIN	Tube	Flap	Seal	
525/65R20.5	XS	4	TL	20	173F			16.8	13000	8.00			551	1231		16.00	558	521	1200	548	3639		16.00	19.5/20.5 UD			
24/70R20.5	XS	4	TL		176F			16.8	14200	6.00						18.00	661	602	1374	620	4150		18.00	20.5 WAMD			
24/70R21	XZL	4	TL	16	176G			25.0	14200	6.00			200	687				663	608	1388	631	4200		18.00			
445/65R22.5	XZL	4	TL		168G			21.0	11200	8.00						14.00	486	448	1168	537	3550		14.00				
13R22.5	XZL	4	TL	18	154/150K			20.2	7500	8.00	13400	8.00	326	1146		9.00 - 9.75	338	307	1130	525	3450	347	9.00				
12.00R24	XDL	4	TT		LRJ			30.4	8000	7.50	14600	7.50				8.50, 8.00	356	323	1255	586	3944	358	8.50				

• (1) ETRTO rating (standard value, the ETRTO standard rim may be different to the rim recommended by MICHELIN). • (2) MICHELIN rating, value measured on rim recommended by MICHELIN. • (3) Unique point: load capacity/authorized additional speed pair Load variations according to speed do not apply to the unique point.

See the next table for the recommended inflation pressure

- 15-16 INCHES
- 17.5 INCHES
- 19.5 INCHES
- 20 INCHES
- 20 AND 24 INCHES
- 19.5 AND 22.5 INCHES WIDEBASE
- 22.5 INCHES
- OFF-ROAD SIZES
- MICHELIN AGILIS 3 SIZES
- MICHELIN XCD2 SIZES

MICHELIN DIMENSIONAL DATA

OFF-ROAD SIZES

Table of inflation pressure (bar) in relation to maximum load per axle (kg)

Dimension	Tread pattern	psi	36	40	44	47	51	54	58	62	65	69	73	76	80	83	87	91	94	98	102	105	109	112	116	120	123	127	131	134		
		bar	2.50	2.75	3.00	3.25	3.50	3.75	4.00	4.25	4.50	4.75	5.00	5.25	5.50	5.75	6.00	6.25	6.50	6.75	7.00	7.25	7.50	7.75	8.00	8.25	8.50	8.75	9.00	9.25		
		525/65R20.5	XS	single											8500	8875	9250	9625	10000	10375	10750	11125	11500	11875	12250	12625	13000					
		dual											-	-	-	-	-	-	-	-	-	-	-	-	-	-						
24/70R20.5	XS	single					9000	9500	10000	10500	11000	11500	12000	12500	13000	13600	14200															
		dual					-	-	-	-	-	-	-	-	-	-	-															
24/70R21	XZL	single					9000	9500	10000	10500	11000	11500	12000	12500	13000	13600	14200															
		dual					-	-	-	-	-	-	-	-	-	-	-															
445/65R22.5	XZL	single											7360	7680	8000	8320	8640	8960	9280	9600	9920	10240	10560	10880	11200							
		dual											-	-	-	-	-	-	-	-	-	-	-	-	-							
13R22.5	XZL	single											4930	5140	5360	5570	5790	6000	6210	6430	6640	6860	7070	7290	7500							
		dual											8810	9190	9570	9950	10340	10720	11100	11490	11870	12250	12630	13020	13400							
12.00R24	XDL	single										5090	5330	5580	5820	6060	6300	6550	6790	7030	7270	7520	7760	8000								
		dual										9290	9730	10180	10620	11060	11500	11950	12390	12830	13270	13720	14160	14600								

- 15-16 INCHES
- 17.5 INCHES
- 19.5 INCHES
- 20 INCHES
- 20 AND 24 INCHES
- 19.5 AND 22.5 INCHES WIDEBASE
- 22.5 INCHES
- OFF-ROAD SIZES
- MICHELIN AGILIS 3 SIZES
- MICHELIN XCD2 SIZES

Dimensional data for general indication only, for official data consult MICHELIN Technical Correspondent.

MICHELIN DIMENSIONAL DATA

MICHELIN AGILIS 3 FOR LIGHT TRUCKS

Dimension	Tread Pattern	Type	Load / Speed Index	Original tread depth	Load Capacity (kgs) Single	Load Capacity (kgs) Dual	Section Width Design Value (mm)	Overall Diameter (mm)	Rolling Circumference (mm)	Min Rim Width (inches)	Measuring Rim Width (inches)	Maxi Rim Width (inches)
185R14C	AGILIS 3	TL	102/100R	8.0	850	800	188	650	1983	4.5	5.0	6.0
195/65R16C	AGILIS 3	TL	104/102R	8.5	900	850	201	660	2013	5.5	6.0	6.0
195/75R16C	AGILIS 3	TL	107/105T	8.0	975	925	196	698	2129	5.0	5.5	6.0
195/80R14C	AGILIS 3	TL	106/104R	8.0	950	900	196	668	2037	5.0	5.5	6.0
195/80R15C	AGILIS 3	TL	108/106S	8.0	1000	950	196	693	2114	5.0	5.5	6.0
205/65R16C	AGILIS 3	TL	107/105T	8.5	975	925	209	672	2050	5.5	6.0	6.5
205/70R15C	AGILIS 3	TL	106/104S	8.0	950	900	209	669	2040	5.5	6.0	6.5
205/75R14C	AGILIS 3	TL	109/107R	8.0	1030	975	203	664	2025	5.5	5.5	6.5
205/75R16C	AGILIS 3	TL	113/111R	8.5	1150	1090	203	714	2178	5.5	5.5	6.5
215/65R15C	AGILIS 3	TL	104/102T	7.5	900	850	221	661	2016	6.0	6.5	7.0
215/65R16C	AGILIS 3	TL	109/107T	8.0	1030	975	221	686	2092	6.0	6.5	7.0
215/70R15C	AGILIS 3	TL	109/107S	8.0	1030	975	221	683	2083	5.5	6.5	7.0
215/70R16C	AGILIS 3	TL	108/106T	8.0	1000	950	221	708	2159	5.5	6.5	7.0
215/75R16C	AGILIS 3	TL	113/111T	8.0	1150	1090	216	728	2220	5.5	6.0	7.0
225/65R16C	AGILIS 3	TL	112/110R	8.5	1120	1060	228	698	2129	6.0	6.5	7.0
225/70R15C	AGILIS 3	TL	112/110S	8.5	1120	1060	228	697	2126	6.0	6.5	7.0
225/75R16C	AGILIS 3	TL	121/120R	7.5	1450	1400	223	744	2269	6.0	6.0	7.0
235/60R17C	AGILIS 3	TL	117/115T	8.0	1285	1215	240	714	2178	6.5	7.0	7.5
235/65R16C	AGILIS 3	TL	121/119R	7.5	1415	1360	240	712	2172	6.5	7.0	7.5
235/65R16C	AGILIS 3	TL	115/113T	8.0	1215	1150	240	712	2172	6.5	7.0	7.5

15-16 INCHES

17.5 INCHES

19.5 INCHES

20 INCHES

20 AND 24 INCHES

19.5 AND 22.5 INCHES WIDEBASE

22.5 INCHES

OFF-ROAD SIZES

MICHELIN AGILIS 3 SIZES

MICHELIN XCD2 SIZES

MICHELIN DIMENSIONAL DATA

MICHELIN XCD2 FOR LIGHT TRUCKS

Dimension	Pattern	Type	Load Index	Load Index (Dual)	Speed Index	Load Capacity (kgs) Single	Load Capacity (Kgs) Dual	Section Width Design Value (mm)	Overall Diameter (mm)	Rolling Circumference (mm)	Min Rim Width (inches)	Measuring Rim Width (inches)	Maxi Rim Width (inches)
195R14C	XCD	TL	106		P	950		198	666	2031	5.00	5.50	6.00
205R14C	XCD	TL	109		P	1030		208	686	2092	5.50	6.00	6.50
215R14C	XCD	TL	112		P	1120		218	714	2178	5.50	6.00	7.00
205/70R15C	XCD	TL	106		Q	950		209	669	2040	5.50	6.00	6.50
215R15C	XCD	TL	112		Q	1120		218	725	2211	5.50	6.00	7.00
205/75R14C	XCD2	TL	109	107	P	1030	975	203	664	2025	5.50	5.50	6.50
215/75R14C	XCD2	TL	112	110	P	1120	1060	216	678	2068	5.50	6.00	7.00
225/75R14C	XCD2	TL	115	113	P	1215	1150	223	693	2114	6.00	6.50	7.00
205/70R15C *	XCD2	TL	106	104	S	950	900	209	669	2040	5.50	6.00	6.50
225/75R15C *	XCD2	TL	116	114	Q	1250	1180	223	719	2193	6.00	7.00	7.50

- 15-16 INCHES
- 17.5 INCHES
- 19.5 INCHES
- 20 INCHES
- 20 AND 24 INCHES
- 19.5 AND 22.5 INCHES WIDEBASE
- 22.5 INCHES
- OFF-ROAD SIZES
- MICHELIN AGILIS 3 SIZES
- MICHELIN XCD2 SIZES

TYRE KNOWLEDGE AND SAFETY



- [TYRE KNOWLEDGE AND SAFETY](#)
- [INFLATION PRESSURE](#)
- [CHECKING THE INFLATION PRESSURE](#)
- [EFFECT OF INFLATION PRESSURE ON TYRE MILEAGE](#)
- [EFFECT OF INFLATION PRESSURE ON FUEL CONSUMPTION](#)
- [THE MICHELIN WARRANTY](#)
- [TYRE-USAGE SAFETY PRECAUTIONS AND GUIDELINES](#)
- [PRODUCT LIFE](#)
- [CORRECT MOUNTING AND INFLATION OF TYRES](#)
- [PROPER TYRE REMOVAL](#)
- [CHECKING THE WHEELS](#)
- [REPLACING TYRES](#)
- [CARE OF TYRE](#)
- [REGROOVING](#)
- [RETREADING](#)
- [STORAGE OF TYRES AND TUBES](#)
- [TRANSFORMATION OF FLAT RIM TO DROP CENTER](#)
- [EQUIVALENT SIZES](#)
- [TRUCK TYRE RIMS](#)
- [DUAL FITTING AND TYPES OF FIXING](#)
- [TRUCK TYRE TUBES AND VALVES](#)
- [MOUNTING AND DEMOUNTING](#)
- [PROTECTED VALVES ON TUBELESS WHEEL](#)

INFLATION PRESSURE

Choosing and maintaining the correct inflation pressure is key for optimum performance.

The tyre is the sole point of contact between the vehicle and the ground.

It is crucial to the safety both of users and goods transported. For a given load and type of work, in clearly defined conditions, there is only one suitable inflation pressure.

The pressure of the air in the tyre is crucial to the correct operation of the tyres: it is this pressure which both supports and moves loads or people:

- Safely
- Durably
- Economically
- Comfortably

However, in the surveys conducted by MICHELIN, pressure often emerges as one of the maintenance points which is often not monitored as well as it should be.

Pressure and safety

Incorrect tyre pressure has a negative impact on certain basic aspects of safety performance such as:

- Casing resistance.
- Vehicle stability and handling.
- Vehicle grip.
- Sensitivity to “kerbing”.

Variation in inflation pressure

During use, a tyre may lose pressure for various different reasons:

Airtightness of the wheel rim (eg. cracks or welds).

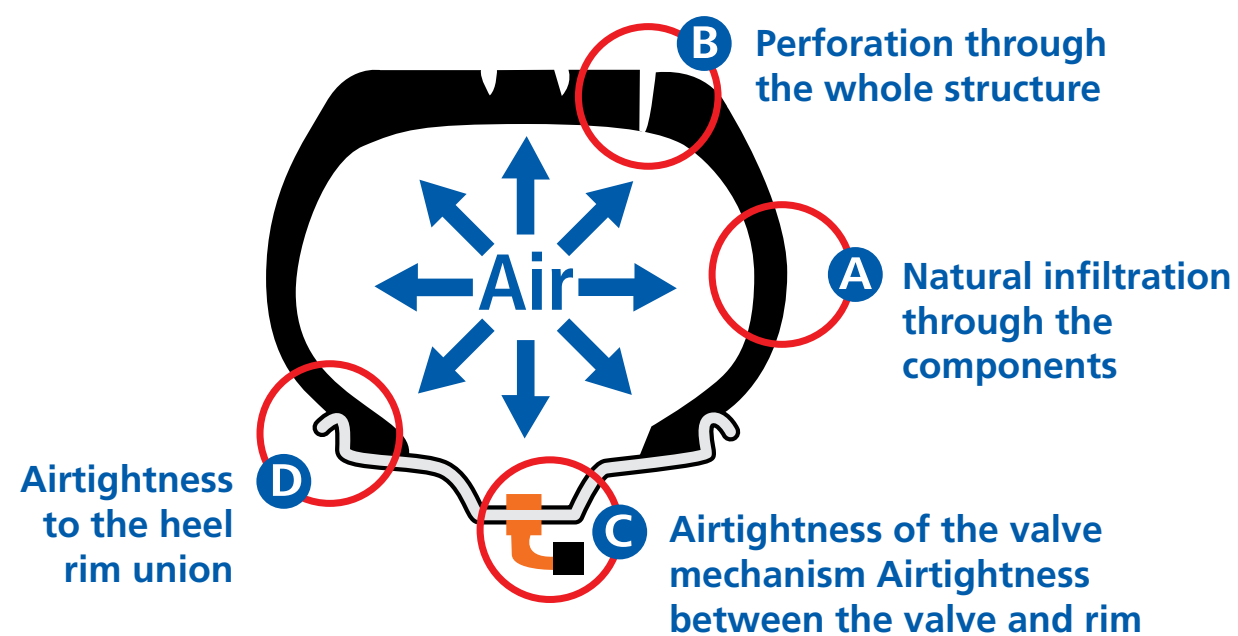

Apart from the vehicle's on-board monitoring systems, visual and periodic pressure checks with a pressure gauge is the most common method for detecting possible air leak problems.

[TYRE KNOWLEDGE AND SAFETY](#)[INFLATION PRESSURE](#)[CHECKING THE INFLATION PRESSURE](#)[EFFECT OF INFLATION PRESSURE ON TYRE MILEAGE](#)[EFFECT OF INFLATION PRESSURE ON FUEL CONSUMPTION](#)[THE MICHELIN WARRANTY](#)[TYRE-USAGE SAFETY PRECAUTIONS AND GUIDELINES](#)[PRODUCT LIFE](#)[CORRECT MOUNTING AND INFLATION OF TYRES](#)[PROPER TYRE REMOVAL](#)[CHECKING THE WHEELS](#)[REPLACING TYRES](#)[CARE OF TYRE](#)[REGROOVING](#)[RETREADING](#)[STORAGE OF TYRES AND TUBES](#)[TRANSFORMATION OF FLAT RIM TO DROP CENTER](#)[EQUIVALENT SIZES](#)[TRUCK TYRE RIMS](#)[DUAL FITTING AND TYPES OF FIXING](#)[TRUCK TYRE TUBES AND VALVES](#)[MOUNTING AND DEMOUNTING](#)[PROTECTED VALVES ON TUBELESS WHEEL](#)

CHECKING THE INFLATION PRESSURE

This check should be made on all the tyres on the vehicle (including the spare wheel)



- If the inflation pressure is too low, the result is an abnormal rise in running temperature which may lead to damage to the internal components.

This damage is irreversible and may cause the destruction of the tyre and sudden total deflation.

The consequences of running with insufficient pressure in the tyres are not necessarily immediate and may even become apparent after the pressure has been corrected.

- Insufficient inflation pressure also greatly increases the risk of impact-pinching related damage and aqua planing.
- UNDER-INFLATION can cause rapid and/or irregular wear and increased sensitivity to impact (tread damage, rupture of casing).
- Inflating tyres with nitrogen does not mean that the inflation pressure (at least once a month) does not need to be checked regularly.

In terms of nominal pressure between 6 and 9 bar

 <p>UNDER-INFLATION up to - 0.5 bar OVER-INFLATION up to + 0.5 bar</p>	 <p>UNDER-INFLATION between - 0.6 and - 1 bar</p>	 <p>UNDER-INFLATION more than - 1 bar</p>
<p>+ safety + longevity - fuel consumption</p>	<p>- longevity + irregular wear + fuel consumption</p>	<p>Rapid degradation in use with risk of sudden total deflation - stability and grip - longevity / irregular wear + fuel consumption</p>
<p>ACCEPTABLE PRESSURE Correct as soon as possible to the suggested level</p>	<p>TEMPORARILY ACCEPTABLE PRESSURE Correct immediately and monitor</p>	<p>UNACCEPTABLE PRESSURE Remove and inspect the interior if mounted in twin configuration: remove and inspect the adjacent mounted assembly</p>

In all cases, the pressures recommended by the manufacturer of the vehicle or tyre must be observed. Tyre inflation pressures must always be appropriate for the load and tyre use.

TYRE KNOWLEDGE AND SAFETY

INFLATION PRESSURE

CHECKING THE INFLATION PRESSURE

EFFECT OF INFLATION PRESSURE ON TYRE MILEAGE

EFFECT OF INFLATION PRESSURE ON FUEL CONSUMPTION

THE MICHELIN WARRANTY

TYRE-USAGE SAFETY PRECAUTIONS AND GUIDELINES

PRODUCT LIFE

CORRECT MOUNTING AND INFLATION OF TYRES

PROPER TYRE REMOVAL

CHECKING THE WHEELS

REPLACING TYRES

CARE OF TYRE

REGROOVING

RETREADING

STORAGE OF TYRES AND TUBES

TRANSFORMATION OF FLAT RIM TO DROP CENTER

EQUIVALENT SIZES

TRUCK TYRE RIMS

DUAL FITTING AND TYPES OF FIXING

TRUCK TYRE TUBES AND VALVES

MOUNTING AND DEMOUNTING

PROTECTED VALVES ON TUBELESS WHEEL

EFFECT OF INFLATION PRESSURE ON TYRE MILEAGE

Under-inflation by 1.5 bar = 10 % mileage loss*

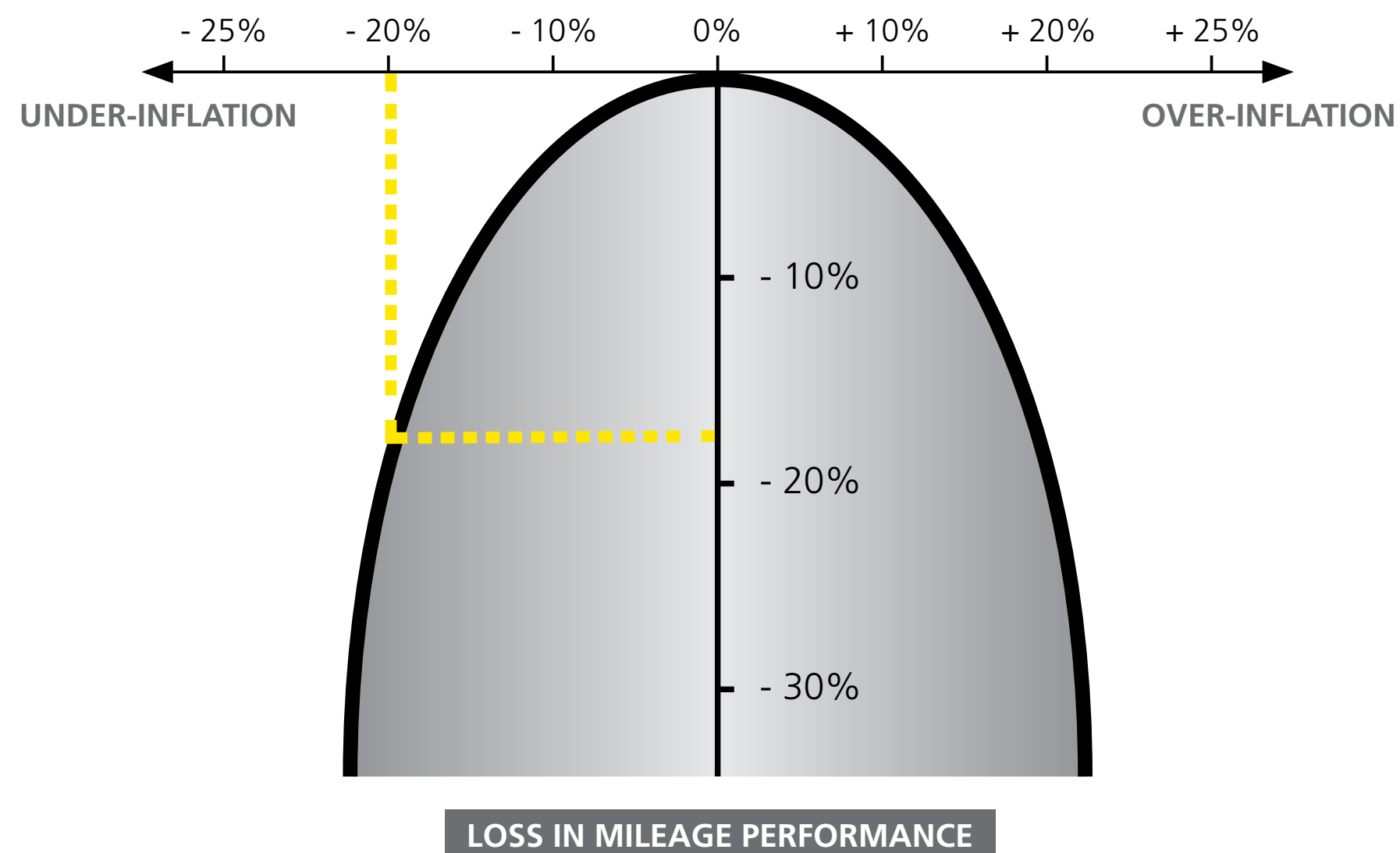

* Internal Michelin source.

RECOMMENDATIONS

- Check the tyre pressures regularly when the tyres are cold at ambient temperature or after the vehicle has stopped for several hours.
- NEVER DEFLATE HOT TYRES.

TYRE KNOWLEDGE AND SAFETY

INFLATION PRESSURE

CHECKING THE INFLATION PRESSURE

EFFECT OF INFLATION PRESSURE ON TYRE MILEAGE

EFFECT OF INFLATION PRESSURE ON FUEL CONSUMPTION

THE MICHELIN WARRANTY

TYRE-USAGE SAFETY PRECAUTIONS AND GUIDELINES

PRODUCT LIFE

CORRECT MOUNTING AND INFLATION OF TYRES

PROPER TYRE REMOVAL

CHECKING THE WHEELS

REPLACING TYRES

CARE OF TYRE

REGROOVING

RETREADING

STORAGE OF TYRES AND TUBES

TRANSFORMATION OF FLAT RIM TO DROP CENTER

EQUIVALENT SIZES

TRUCK TYRE RIMS

DUAL FITTING AND TYPES OF FIXING

TRUCK TYRE TUBES AND VALVES

MOUNTING AND DEMOUNTING

PROTECTED VALVES ON TUBELESS WHEEL

Home

EFFECT OF INFLATION PRESSURE ON FUEL CONSUMPTION

Inflation pressure has a proven influence on fuel consumption. An unsuitable inflation pressure increases the tyre rolling resistance and thus the vehicle's fuel consumption.

Under-inflation by 1.5 bar = 1 % increased fuel consumption*

Increased fuel consumption of tyre at 7.5 bar for recommendation of 9 bar or 17% under-inflated

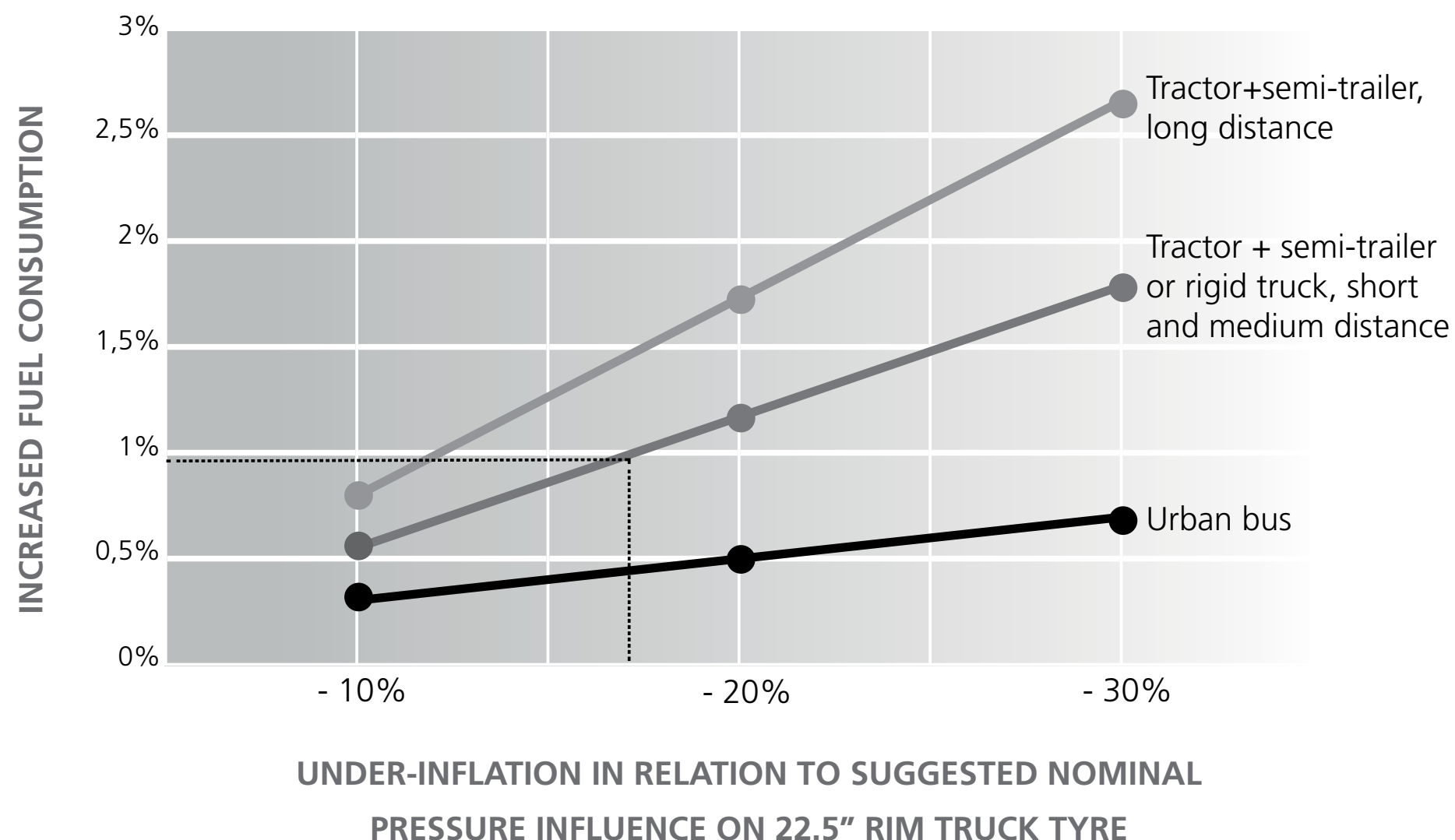

* Internal Michelin source.

TYRE KNOWLEDGE AND SAFETY

INFLATION PRESSURE

CHECKING THE INFLATION PRESSURE

EFFECT OF INFLATION PRESSURE ON TYRE MILEAGE

EFFECT OF INFLATION PRESSURE ON FUEL CONSUMPTION

THE MICHELIN WARRANTY

TYRE-USAGE SAFETY PRECAUTIONS AND GUIDELINES

PRODUCT LIFE

CORRECT MOUNTING AND INFLATION OF TYRES

PROPER TYRE REMOVAL

CHECKING THE WHEELS

REPLACING TYRES

CARE OF TYRE

REGROOVING

RETREADING

STORAGE OF TYRES AND TUBES

TRANSFORMATION OF FLAT RIM TO DROP CENTER

EQUIVALENT SIZES

TRUCK TYRE RIMS

DUAL FITTING AND TYPES OF FIXING

TRUCK TYRE TUBES AND VALVES

MOUNTING AND DEMOUNTING

PROTECTED VALVES ON TUBELESS WHEEL

THE MICHELIN WARRANTY



FOR COMMERCIAL TRUCK AND BUS TYRES, TUBES AND FLAPS

Michelin promises to deliver the very best. And with over a century of designing tyres, we back that promise. Our tyres are made to meet meticulous quality standards. That's why every new tyre designed and manufactured by Michelin is warranted by Michelin.

Every MICHELIN Truck Tyre, Tube and Flap bearing the MICHELIN brand and complete serial and identification numbers, used in normal service and in accordance with the maintenance recommendations and safety warnings of the MICHELIN Group is covered against defects in design, workmanship and materials for the life of the original usable tread or 5 years from the date of invoice (or date of manufacture if no proof of purchase is presented) whichever comes first. The original usable tread is the original tread down to the level of the tread wear indicators (1.5 mm of tread remaining) at which time the Tyre is considered to be worn out.

The Michelin Product warranty does not include/provide compensation for loss of time, loss of use of vehicle, inconvenience or incidental or consequential damages. Tyre presented for claim remains the property of the owner/consumer. Michelin accepts no responsibility for loss of, or damage to, tyres which are in the custody or control of a Michelin authorized tyre dealer for inspection purpose for warranty adjustment. Only after tyre is accepted for claim it becomes the property of Michelin Country. Additionally the cost of fitting, balancing, and any other service charges and applicable taxes has to be borne by consumer in case of accepted claim.

To read the full terms and conditions, please ask your local Michelin representative or dealer.

This warranty is applied in (country) only.

[TYRE KNOWLEDGE AND SAFETY](#)[INFLATION PRESSURE](#)[CHECKING THE INFLATION PRESSURE](#)[EFFECT OF INFLATION PRESSURE ON TYRE MILEAGE](#)[EFFECT OF INFLATION PRESSURE ON FUEL CONSUMPTION](#)[THE MICHELIN WARRANTY](#)[TYRE-USAGE SAFETY PRECAUTIONS AND GUIDELINES](#)[PRODUCT LIFE](#)[CORRECT MOUNTING AND INFLATION OF TYRES](#)[PROPER TYRE REMOVAL](#)[CHECKING THE WHEELS](#)[REPLACING TYRES](#)[CARE OF TYRE](#)[REGROOVING](#)[RETREADING](#)[STORAGE OF TYRES AND TUBES](#)[TRANSFORMATION OF FLAT RIM TO DROP CENTER](#)[EQUIVALENT SIZES](#)[TRUCK TYRE RIMS](#)[DUAL FITTING AND TYPES OF FIXING](#)[TRUCK TYRE TUBES AND VALVES](#)[MOUNTING AND DEMOUNTING](#)[PROTECTED VALVES ON TUBELESS WHEEL](#)

TYRE-USAGE SAFETY PRECAUTIONS AND GUIDELINES

PRODUCT LIFE

Tyres are constructed using various types of material and components where the properties evolve over time.

This evolution depends upon the storage conditions (temperature, humidity, position, etc.) and conditions of use (load, speed, inflation pressure, condition of wheels, etc.) to which the tyre is subjected.

Since the aging factors vary and are difficult to measure, that is why in addition to regular inspections by the user, Michelin recommends that tyres should be inspected regularly by a qualified tyre specialist who will assess the tyre's suitability for continued service.

This inspection must take place at least once a year. If the tyre has been in use, it must be inspected at the earliest upon 5 years in circulation. If the tyre has not been in use, it must be checked at the earliest upon 8 years.

At the end of one of these periods, in addition to the normal visual aspect and pressure check, tyres should be inspected annually by a tyre specialist.

It is recommended that tyres 10 years or older are not used on steering axles of trucks and buses.

It is recommended that they be used on Trailer (T) axles.

Failure to follow these recommendations may lead to a reduction in the performance of your vehicle and cause it to respond abnormally and/or a tyre malfunction could pose a safety risk to drivers and others. Michelin shall not be responsible under any circumstances for damage that occurs as a result of and/or during use that does not comply with its guidelines.

[TYRE KNOWLEDGE AND SAFETY](#)[INFLATION PRESSURE](#)[CHECKING THE INFLATION PRESSURE](#)[EFFECT OF INFLATION PRESSURE ON TYRE MILEAGE](#)[EFFECT OF INFLATION PRESSURE ON FUEL CONSUMPTION](#)[THE MICHELIN WARRANTY](#)[TYRE-USAGE SAFETY PRECAUTIONS AND GUIDELINES](#)[PRODUCT LIFE](#)[CORRECT MOUNTING AND INFLATION OF TYRES](#)[PROPER TYRE REMOVAL](#)[CHECKING THE WHEELS](#)[REPLACING TYRES](#)[CARE OF TYRE](#)[REGROOVING](#)[RETREADING](#)[STORAGE OF TYRES AND TUBES](#)[TRANSFORMATION OF FLAT RIM TO DROP CENTER](#)[EQUIVALENT SIZES](#)[TRUCK TYRE RIMS](#)[DUAL FITTING AND TYPES OF FIXING](#)[TRUCK TYRE TUBES AND VALVES](#)[MOUNTING AND DEMOUNTING](#)[PROTECTED VALVES ON TUBELESS WHEEL](#)

TYRE-USAGE SAFETY PRECAUTIONS AND GUIDELINES

CORRECT MOUNTING AND INFLATION OF TYRES

GENERAL PRECAUTIONS: BEFORE COMMENCING TYRE FITTING PROCESS

- Before commencing the tyre fitting process, the conformity and compatibility of the tyre must be checked.
- Correct tyre fitting, carried out with the recommended methods of work and in line with the safety rules in force, helps to ensure that personnel and equipment are fully protected and will be used to their full potential.
- The operators must always be equipped with their usual protective clothing (ear defenders, gloves, safety shoes, safety goggles, etc.).
- The operators must be properly trained for the work.
- The operators must make sure that the vehicle is stationary with its engine switched off and that the vehicle is correctly stabilised (parking brake, chock, axle stands, etc.).

[TYRE KNOWLEDGE AND SAFETY](#)[INFLATION PRESSURE](#)[CHECKING THE INFLATION PRESSURE](#)[EFFECT OF INFLATION PRESSURE ON TYRE MILEAGE](#)[EFFECT OF INFLATION PRESSURE ON FUEL CONSUMPTION](#)[THE MICHELIN WARRANTY](#)[TYRE-USAGE SAFETY PRECAUTIONS AND GUIDELINES](#)[PRODUCT LIFE](#)[CORRECT MOUNTING AND INFLATION OF TYRES](#)[PROPER TYRE REMOVAL](#)[CHECKING THE WHEELS](#)[REPLACING TYRES](#)[CARE OF TYRE](#)[REGROOVING](#)[RETREADING](#)[STORAGE OF TYRES AND TUBES](#)[TRANSFORMATION OF FLAT RIM TO DROP CENTER](#)[EQUIVALENT SIZES](#)[TRUCK TYRE RIMS](#)[DUAL FITTING AND TYPES OF FIXING](#)[TRUCK TYRE TUBES AND VALVES](#)[MOUNTING AND DEMOUNTING](#)[PROTECTED VALVES ON TUBELESS WHEEL](#)

TYRE-USAGE SAFETY PRECAUTIONS AND GUIDELINES

CORRECT MOUNTING AND INFLATION OF TYRES

TYRE FITTING PRECAUTIONS

- Make sure that the wheel and its components are in good condition.
- Check the compatibility of tyre and wheel, tyre and vehicle and tyre and use.
- Respect the positions, fitting direction, direction of rotation and any relevant instructions when mentioned on the tyre sidewalls.
- Make sure that the inside of the tyre is clean, dry and free of foreign matter. For a tyre which has already been used on the road, check carefully that the inside of the tyre does not show any signs of having run under-inflated (mottling, dislocation).
- Change the valve seal or valve.
- Inflate the tyre safely following the inflation steps. Make sure that all of the components are correctly in place. **Never stand facing a fitted tyre but stand in line with the tread, at least 3 metres away.**
- All of these precautions must be used for both new tyres and tyres that have already been used on the road.
- We recommend fitting tyres on wheels with protected valves for vehicles equipped with disc brakes to prevent the risk of the valve being damaged by an object jammed between the brake and the wheel.

Incorrect fitting may lead to damage to tyres, the vehicle, or injury to persons (serious or even fatal injury).

[TYRE KNOWLEDGE AND SAFETY](#)[INFLATION PRESSURE](#)[CHECKING THE INFLATION PRESSURE](#)[EFFECT OF INFLATION PRESSURE ON TYRE MILEAGE](#)[EFFECT OF INFLATION PRESSURE ON FUEL CONSUMPTION](#)[THE MICHELIN WARRANTY](#)[TYRE-USAGE SAFETY PRECAUTIONS AND GUIDELINES](#)[PRODUCT LIFE](#)[CORRECT MOUNTING AND INFLATION OF TYRES](#)[PROPER TYRE REMOVAL](#)[CHECKING THE WHEELS](#)[REPLACING TYRES](#)[CARE OF TYRE](#)[REGROOVING](#)[RETREADING](#)[STORAGE OF TYRES AND TUBES](#)[TRANSFORMATION OF FLAT RIM TO DROP CENTER](#)[EQUIVALENT SIZES](#)[TRUCK TYRE RIMS](#)[DUAL FITTING AND TYPES OF FIXING](#)[TRUCK TYRE TUBES AND VALVES](#)[MOUNTING AND DEMOUNTING](#)[PROTECTED VALVES ON TUBELESS WHEEL](#)

TYRE-USAGE SAFETY PRECAUTIONS AND GUIDELINES



CORRECT MOUNTING AND INFLATION OF TYRES

Tyre Pressure Safety Process

- This must be carried out by trained competent personnel using the correct equipment. Incorrect fitting can result in damage to the tyre (may not be visible at the time of fitting), tube or wheel.
- The cold tyre inflation pressure must be defined in relation to the load, speed and conditions of use.
- Michelin recommends inflating tyres in an “inflation cage”.
- The inflation must be carried out in 2 stages:

FIRST STAGE:

- pre-inflate to 1.5 bar;
- inspect the tyre; if in doubt, stop the operation and call a tyre specialist.

SECOND STAGE

- inflate the tyre to the required pressure;
- place the tyre into the inflation cage or vertically in a suitably equipped area.

Position yourself in line with the tread and at least 3 m away during inflation.

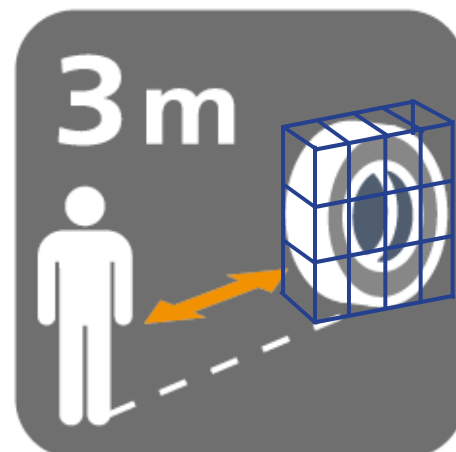

TYRE KNOWLEDGE AND SAFETY

INFLATION PRESSURE

CHECKING THE INFLATION PRESSURE

EFFECT OF INFLATION PRESSURE ON TYRE MILEAGE

EFFECT OF INFLATION PRESSURE ON FUEL CONSUMPTION

THE MICHELIN WARRANTY

TYRE-USAGE SAFETY PRECAUTIONS AND GUIDELINES

PRODUCT LIFE

CORRECT MOUNTING AND INFLATION OF TYRES

PROPER TYRE REMOVAL

CHECKING THE WHEELS

REPLACING TYRES

CARE OF TYRE

REGROOVING

RETREADING

STORAGE OF TYRES AND TUBES

TRANSFORMATION OF FLAT RIM TO DROP CENTER

EQUIVALENT SIZES

TRUCK TYRE RIMS

DUAL FITTING AND TYPES OF FIXING

TRUCK TYRE TUBES AND VALVES

MOUNTING AND DEMOUNTING

PROTECTED VALVES ON TUBELESS WHEEL

TYRE-USAGE SAFETY PRECAUTIONS AND GUIDELINES

INFLATION PRESSURE

MORE IMPORTANT SAFETY PRECAUTIONS

- Use an accurate, regularly calibrated pressure gauge and handle it with care.
- Tyre pressures must be checked on cold tyres.
- Comply with the inflation pressures recommended by the vehicle or tyre manufacturer.
- Tyre inflation pressures must always be appropriate for the load and tyre use.
- Always observe the regulation in force in the country of use.
- Check the tyre pressures regularly when the tyres are cold at ambient temperature or after the vehicle has stopped for several hours.
- The pressure should be checked 24 hours after a tyre has been fitted and must not have reduced by more than 5% of the original pressure.
- The inflation pressures of the tyres on the same axle should normally be about the same.
- The pressure increases in use; **never reduce the pressure of a tyre while it is hot.**
- If the pressure in a tyre checked when hot is lower than the suggested pressure or seems hotter, the tyre must be removed and checked, complying with the safety instructions.
- Never re-inflate a tyre which has been running underinflated without a thorough inspection both inside and out.
- Tyre pressures greater than 10 bar when cold are strictly not recommended.

FOR CORRECT MOUNTING OF THE TYRE AND INFLATING PRESSURE, PLEASE READ PAGES 91-93.

[TYRE KNOWLEDGE AND SAFETY](#)[INFLATION PRESSURE](#)[CHECKING THE INFLATION PRESSURE](#)[EFFECT OF INFLATION PRESSURE ON TYRE MILEAGE](#)[EFFECT OF INFLATION PRESSURE ON FUEL CONSUMPTION](#)[THE MICHELIN WARRANTY](#)[TYRE-USAGE SAFETY PRECAUTIONS AND GUIDELINES](#)[PRODUCT LIFE](#)[CORRECT MOUNTING AND INFLATION OF TYRES](#)[PROPER TYRE REMOVAL](#)[CHECKING THE WHEELS](#)[REPLACING TYRES](#)[CARE OF TYRE](#)[REGROOVING](#)[RETREADING](#)[STORAGE OF TYRES AND TUBES](#)[TRANSFORMATION OF FLAT RIM TO DROP CENTER](#)[EQUIVALENT SIZES](#)[TRUCK TYRE RIMS](#)[DUAL FITTING AND TYPES OF FIXING](#)[TRUCK TYRE TUBES AND VALVES](#)[MOUNTING AND DEMOUNTING](#)[PROTECTED VALVES ON TUBELESS WHEEL](#)

TYRE-USAGE SAFETY PRECAUTIONS AND GUIDELINES

TYRE REMOVAL

PROPER TYRE REMOVAL

When removing the wheel from the vehicle

- If the tyre is part of a dual fitment or if the rim shows obvious damage, the tyres must be deflated by removing the valve core.
- Comply with the vehicle manufacturer's recommendations and instructions.

Removing the tyre with the wheel still fitted to the vehicle

Michelin does not recommend this method. In fact, manipulation during removal can create a fold in the casing ply at the bottom, and increase the risk of the plies breaking whilst on the move. This method should only be used if it is not possible to remove the wheel. In this case, deflate the tyre completely by removing the valve core.

[TYRE KNOWLEDGE AND SAFETY](#)[INFLATION PRESSURE](#)[CHECKING THE INFLATION PRESSURE](#)[EFFECT OF INFLATION PRESSURE ON TYRE MILEAGE](#)[EFFECT OF INFLATION PRESSURE ON FUEL CONSUMPTION](#)[THE MICHELIN WARRANTY](#)[TYRE-USAGE SAFETY PRECAUTIONS AND GUIDELINES](#)[PRODUCT LIFE](#)[CORRECT MOUNTING AND INFLATION OF TYRES](#)[PROPER TYRE REMOVAL](#)[CHECKING THE WHEELS](#)[REPLACING TYRES](#)[CARE OF TYRE](#)[REGROOVING](#)[RETREADING](#)[STORAGE OF TYRES AND TUBES](#)[TRANSFORMATION OF FLAT RIM TO DROP CENTER](#)[EQUIVALENT SIZES](#)[TRUCK TYRE RIMS](#)[DUAL FITTING AND TYPES OF FIXING](#)[TRUCK TYRE TUBES AND VALVES](#)[MOUNTING AND DEMOUNTING](#)[PROTECTED VALVES ON TUBELESS WHEEL](#)

TYRE-USAGE SAFETY PRECAUTIONS AND GUIDELINES

CHECKING THE WHEELS

WHEEL INSTALLATION ON VEHICLE

After fitting the wheel on the vehicle, the wheel nuts must be tightened with a calibrated torque device to the torque setting defined by the vehicle manufacturer. The correct wheel tightening process is essential to maintain wheel security, and along with it your safety.

WHEELS CONDITION

- The condition of all wheels should be regularly checked. Any cracked wheel or rim should be replaced.
- Wheels or rims should not be repaired by welding.
- If a welding operation has to be undertaken, the tyre must be removed from the rim. If this is not done, there is a serious risk of explosion.
- The tyre should only be refitted when all items have returned to ambient temperature.
- Before any welding on the vehicle chassis or in proximity of the tyres, the tyre and wheel assemblies should be removed from the vehicle.
- Before removing divided wheel assemblies from a vehicle, it is recommended that the tyres are deflated.

[TYRE KNOWLEDGE AND SAFETY](#)[INFLATION PRESSURE](#)[CHECKING THE INFLATION PRESSURE](#)[EFFECT OF INFLATION PRESSURE ON TYRE MILEAGE](#)[EFFECT OF INFLATION PRESSURE ON FUEL CONSUMPTION](#)[THE MICHELIN WARRANTY](#)[TYRE-USAGE SAFETY PRECAUTIONS AND GUIDELINES](#)[PRODUCT LIFE](#)[CORRECT MOUNTING AND INFLATION OF TYRES](#)[PROPER TYRE REMOVAL](#)[CHECKING THE WHEELS](#)[REPLACING TYRES](#)[CARE OF TYRE](#)[REGROOVING](#)[RETREADING](#)[STORAGE OF TYRES AND TUBES](#)[TRANSFORMATION OF FLAT RIM TO DROP CENTER](#)[EQUIVALENT SIZES](#)[TRUCK TYRE RIMS](#)[DUAL FITTING AND TYPES OF FIXING](#)[TRUCK TYRE TUBES AND VALVES](#)[MOUNTING AND DEMOUNTING](#)[PROTECTED VALVES ON TUBELESS WHEEL](#)

TYRE-USAGE SAFETY PRECAUTIONS AND GUIDELINES

REPLACING TYRES

Michelin recommends mounting tyres with the same tread pattern on the same axle. If this is not possible, Michelin advises mounting dual tyres of the same type.

Check local legislation

Fitting tyres with different tread patterns is allowed provided they have:

- the same brand
- the same certification number
- the same size
- the same structure (radial or diagonal)
- the same category of use (road, special, snow tyres with M+S marking)
- identical load capacity indices
- and the same speed rating.

Reminder: for technical reasons, we recommend not mounting tyres with a deviation of more than 10 mm in diameter on the same axle.

Please refer to the regulations of each country for specific adaptation.

[TYRE KNOWLEDGE AND SAFETY](#)[INFLATION PRESSURE](#)[CHECKING THE INFLATION PRESSURE](#)[EFFECT OF INFLATION PRESSURE ON TYRE MILEAGE](#)[EFFECT OF INFLATION PRESSURE ON FUEL CONSUMPTION](#)[THE MICHELIN WARRANTY](#)[TYRE-USAGE SAFETY PRECAUTIONS AND GUIDELINES](#)[PRODUCT LIFE](#)[CORRECT MOUNTING AND INFLATION OF TYRES](#)[PROPER TYRE REMOVAL](#)[CHECKING THE WHEELS](#)[REPLACING TYRES](#)[CARE OF TYRE](#)[REGROOVING](#)[RETREADING](#)[STORAGE OF TYRES AND TUBES](#)[TRANSFORMATION OF FLAT RIM TO DROP CENTER](#)[EQUIVALENT SIZES](#)[TRUCK TYRE RIMS](#)[DUAL FITTING AND TYPES OF FIXING](#)[TRUCK TYRE TUBES AND VALVES](#)[MOUNTING AND DEMOUNTING](#)[PROTECTED VALVES ON TUBELESS WHEEL](#)

TYRE-USAGE SAFETY PRECAUTIONS AND GUIDELINES

CARE OF TYRE

Tyres must be examined regularly. To do so, make sure that the vehicle is stationary and the engine is switched off.

- **Michelin recommends that a tyre professional examines the tyre for:**
 - Any signs of abnormal wear, perforations, cuts, deformations on the tread, sidewalls or hanging area of the tyre
 - Any deterioration of the rim flange.
 - Where it is put back on the wheel, be reassured that the tyre has been removed to visually examine the interior.
- **Causes of vehicle handling problems (eg.: pulling to left or right or concerning driver comfort - eg.: vibrations) must be investigated.**
- **If loss of pressure occurs, it is imperative to stop as quickly as possible, as running underinflated causes thermal degradation of the tyre components.**
- **The tyre should be removed from the rim to determine the reason for the loss of pressure.**
- **Any damage must be examined by a tyre professional who is capable of determining if a repair is necessary or possible.**
- **Repairs must be undertaken by a tyre specialist, who will accept responsibility for the repair.**
- **Before any repair, the interior of the tyre must be examined to ensure no degradation has occurred.**

[TYRE KNOWLEDGE AND SAFETY](#)[INFLATION PRESSURE](#)[CHECKING THE INFLATION PRESSURE](#)[EFFECT OF INFLATION PRESSURE ON TYRE MILEAGE](#)[EFFECT OF INFLATION PRESSURE ON FUEL CONSUMPTION](#)[THE MICHELIN WARRANTY](#)[TYRE-USAGE SAFETY PRECAUTIONS AND GUIDELINES](#)[PRODUCT LIFE](#)[CORRECT MOUNTING AND INFLATION OF TYRES](#)[PROPER TYRE REMOVAL](#)[CHECKING THE WHEELS](#)[REPLACING TYRES](#)[CARE OF TYRE](#)[REGROOVING](#)[RETREADING](#)[STORAGE OF TYRES AND TUBES](#)[TRANSFORMATION OF FLAT RIM TO DROP CENTER](#)[EQUIVALENT SIZES](#)[TRUCK TYRE RIMS](#)[DUAL FITTING AND TYPES OF FIXING](#)[TRUCK TYRE TUBES AND VALVES](#)[MOUNTING AND DEMOUNTING](#)[PROTECTED VALVES ON TUBELESS WHEEL](#)

TYRE-USAGE SAFETY PRECAUTIONS AND GUIDELINES

REGROOVING

It is the operator's responsibility to ensure that regrooving is carried out in accordance with the tyre manufacturers' recommendations (pattern, depth, blade, etc.).

Regrooving when there is 2 to 4 mm of tread left makes it possible to:

- Re-establish the tread pattern.
- Adjust the depth of regrooving to ensure that there is always a 2 mm depth of undertread rubber when the tyre no longer has a regroove depth indicator showing.

Regrooving that is too deep

Can cause damage to the tyre resulting in premature removal from service and compromising retreading; exposing the plies beneath the tread is prohibited.

Do not regroove if:

The tread pattern shows signs of significant accidental damage: penetrations, cuts, tearing, etc. In this condition there is a risk of oxidisation of the metallic reinforcing plies: damage of this nature could lead to rapid deterioration of the tyre whilst in service, possibly leading to rapid deflation.

Manage regrooved tyres stock:

To minimise vehicle down time, due to the action of regrooving, we advise that you have a stock of built up regrooved tyres.

For more details, please refer to the Michelin Regroove Manual or contact your local Michelin Representatives.

[TYRE KNOWLEDGE AND SAFETY](#)[INFLATION PRESSURE](#)[CHECKING THE INFLATION PRESSURE](#)[EFFECT OF INFLATION PRESSURE ON TYRE MILEAGE](#)[EFFECT OF INFLATION PRESSURE ON FUEL CONSUMPTION](#)[THE MICHELIN WARRANTY](#)[TYRE-USAGE SAFETY PRECAUTIONS AND GUIDELINES](#)[PRODUCT LIFE](#)[CORRECT MOUNTING AND INFLATION OF TYRES](#)[PROPER TYRE REMOVAL](#)[CHECKING THE WHEELS](#)[REPLACING TYRES](#)[CARE OF TYRE](#)[REGROOVING](#)[RETREADING](#)[STORAGE OF TYRES AND TUBES](#)[TRANSFORMATION OF FLAT RIM TO DROP CENTER](#)[EQUIVALENT SIZES](#)[TRUCK TYRE RIMS](#)[DUAL FITTING AND TYPES OF FIXING](#)[TRUCK TYRE TUBES AND VALVES](#)[MOUNTING AND DEMOUNTING](#)[PROTECTED VALVES ON TUBELESS WHEEL](#)

TYRE-USAGE SAFETY PRECAUTIONS AND GUIDELINES

RETREADING

Since MICHELIN® radial tyres are manufactured to very precise tolerances, it is necessary for similar standards of accuracy to be maintained during the retreading process. Suitably designed modern equipment for radial tyres must be provided in the retread shop.

The proper tread designs, tread width, tread compound, and tread depths, must be selected according to the type of tyre and its anticipated service.

The tyre must be processed with precision to maintain the design characteristics of the MICHELIN® radial. As there is very little margin for error when retreading radial tyres, perfection should be the only standard acceptable.

For more information, contact your local Michelin Representative or MRT Dealer.

[TYRE KNOWLEDGE AND SAFETY](#)[INFLATION PRESSURE](#)[CHECKING THE INFLATION PRESSURE](#)[EFFECT OF INFLATION PRESSURE ON TYRE MILEAGE](#)[EFFECT OF INFLATION PRESSURE ON FUEL CONSUMPTION](#)[THE MICHELIN WARRANTY](#)[TYRE-USAGE SAFETY PRECAUTIONS AND GUIDELINES](#)[PRODUCT LIFE](#)[CORRECT MOUNTING AND INFLATION OF TYRES](#)[PROPER TYRE REMOVAL](#)[CHECKING THE WHEELS](#)[REPLACING TYRES](#)[CARE OF TYRE](#)[REGROOVING](#)[RETREADING](#)[STORAGE OF TYRES AND TUBES](#)[TRANSFORMATION OF FLAT RIM TO DROP CENTER](#)[EQUIVALENT SIZES](#)[TRUCK TYRE RIMS](#)[DUAL FITTING AND TYPES OF FIXING](#)[TRUCK TYRE TUBES AND VALVES](#)[MOUNTING AND DEMOUNTING](#)[PROTECTED VALVES ON TUBELESS WHEEL](#)

TYRE-USAGE SAFETY PRECAUTIONS AND GUIDELINES

STORAGE OF TYRES AND TUBES

CONDITIONS FOR GOOD TYRE STORAGE

- Clean, airy, dry, temperate and well-ventilated premises, sheltered from direct sunlight and bad weather.
- Away from any chemical substance, solvent or hydrocarbon likely to alter the nature of the rubber.
- Away from any object which might penetrate the rubber (metal spike, wood, etc.).
- Away from any heat source, flames, incandescent objects, equipment which may produce sparks or other electrical discharges and any source of ozone (transformers, electric motors, welding stations, etc.).
- If stacked, make sure that the tyres are not deformed.
- For long term storage, rotate the tyres (reverse the order of the tyres in the stack), in order to be able to remove the oldest tyres first.
- Avoid crushing the tyres under other objects.
- Storage:
 - For short term storage (up to 4 weeks) tyres can be stacked horizontally, one on top of the other, on wooden pallets. The height of the stack should not exceed 1.2 metres. After 4 weeks, the tyres should be reversed in the stack. When fitted on rims, tyres should be stored inflated in an upright position or in a single layer on shelf racks.
 - For long term storage, tyres should be stored upright in a single layer on shelf racks with at least 10 cm clearance above the floor. To avoid deformation, it is advisable to rotate them once a month.
- Inner tubes:
 - Tyre inner tubes should either be slightly inflated, dusted with talcum and placed in the tyres or stored in a deflated condition in small stacks max. 50 cm in the compartments of shelf racks with a level bottom. Slatted wooden pallets are not suitable since they might apply pressure at particular points.
 - If the inner tubes are supplied by the manufacturer in cartons or wrapped in film, they should be left in these because the packing provides some degree of protection against contamination, oxygen and the effects of light.
- Flaps:
 - Flaps should in principle be placed with the inner tubes inside the tyres, but if stored separately, they should be laid flat on shelves free from contamination, dust, grease and moisture. Never suspend them, this can cause deformation and elongation.

[TYRE KNOWLEDGE AND SAFETY](#)[INFLATION PRESSURE](#)[CHECKING THE INFLATION PRESSURE](#)[EFFECT OF INFLATION PRESSURE ON TYRE MILEAGE](#)[EFFECT OF INFLATION PRESSURE ON FUEL CONSUMPTION](#)[THE MICHELIN WARRANTY](#)[TYRE-USAGE SAFETY PRECAUTIONS AND GUIDELINES](#)[PRODUCT LIFE](#)[CORRECT MOUNTING AND INFLATION OF TYRES](#)[PROPER TYRE REMOVAL](#)[CHECKING THE WHEELS](#)[REPLACING TYRES](#)[CARE OF TYRE](#)[REGROOVING](#)[RETREADING](#)[STORAGE OF TYRES AND TUBES](#)[TRANSFORMATION OF FLAT RIM TO DROP CENTER](#)[EQUIVALENT SIZES](#)[TRUCK TYRE RIMS](#)[DUAL FITTING AND TYPES OF FIXING](#)[TRUCK TYRE TUBES AND VALVES](#)[MOUNTING AND DEMOUNTING](#)[PROTECTED VALVES ON TUBELESS WHEEL](#)

TYRE-USAGE SAFETY PRECAUTIONS AND GUIDELINES

STORAGE OF TYRES AND TUBES

ADDITIONAL MICHELIN STORAGE INFORMATION

- Tyres which are stored for longer than five years should be examined by competent personnel to determine their suitability for further use.
- It is strongly recommended that tyres which are to be stored inflated, should be inflated with nitrogen.
- If air is used then it must be as dry as possible.
- Ensure that a valve cap is in place.
- For vehicles with use over a limited period:
 - inflate to normal pressure
 - check that pressure checked every six months
 - rotate the tyres by a quarter of a turn every four months
 - drive the tyres for a distance every year to avoid flat spotting.
- Tyres on vehicles suspended off the ground should be deflated to approximately half the normal pressure for the vehicle.
- Spare tyres in storage should also be deflated to approximately half the normal pressure for the vehicle.
- A procedure must be established to ensure that tyres which have been in storage at reduced pressure, are correctly re-inflated when they are returned to service.
- Any tyre which has been stored, should be visually inspected by competent personnel before entering or re-entering service.

[TYRE KNOWLEDGE AND SAFETY](#)[INFLATION PRESSURE](#)[CHECKING THE INFLATION PRESSURE](#)[EFFECT OF INFLATION PRESSURE ON TYRE MILEAGE](#)[EFFECT OF INFLATION PRESSURE ON FUEL CONSUMPTION](#)[THE MICHELIN WARRANTY](#)[TYRE-USAGE SAFETY PRECAUTIONS AND GUIDELINES](#)[PRODUCT LIFE](#)[CORRECT MOUNTING AND INFLATION OF TYRES](#)[PROPER TYRE REMOVAL](#)[CHECKING THE WHEELS](#)[REPLACING TYRES](#)[CARE OF TYRE](#)[REGROOVING](#)[RETREADING](#)[STORAGE OF TYRES AND TUBES](#)[TRANSFORMATION OF FLAT RIM TO DROP CENTER](#)[EQUIVALENT SIZES](#)[TRUCK TYRE RIMS](#)[DUAL FITTING AND TYPES OF FIXING](#)[TRUCK TYRE TUBES AND VALVES](#)[MOUNTING AND DEMOUNTING](#)[PROTECTED VALVES ON TUBELESS WHEEL](#)

TRANSFORMATION FLAT RIM TO DROP CENTER

To carry out a transformation from flat rim to drop center, it is necessary :

- To know the conditions of use of the vehicles.
- To check the loads carried.
- To know the type and the state of the hubs on the vehicles (spider hubs and flange hub).

Then, a study on the field is necessary to validate these elements.

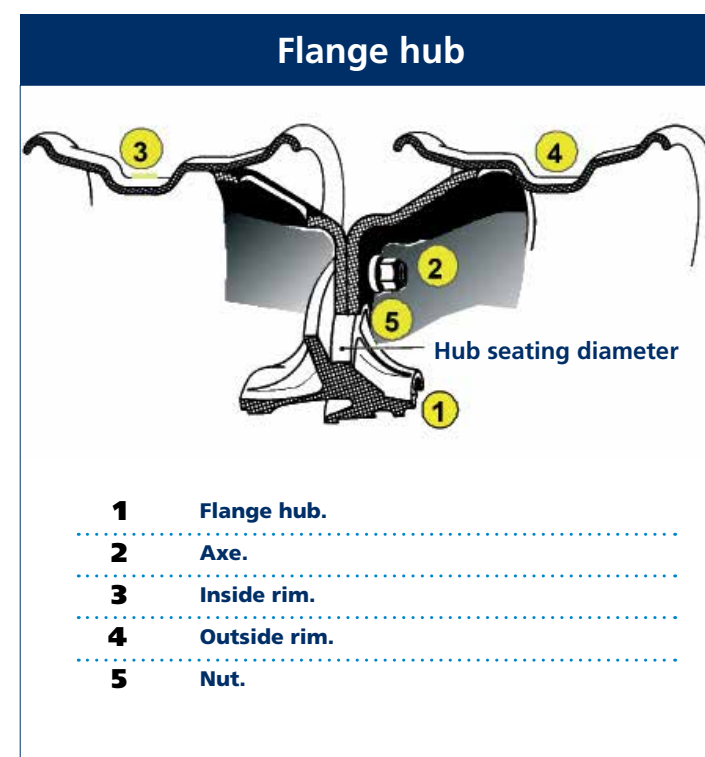
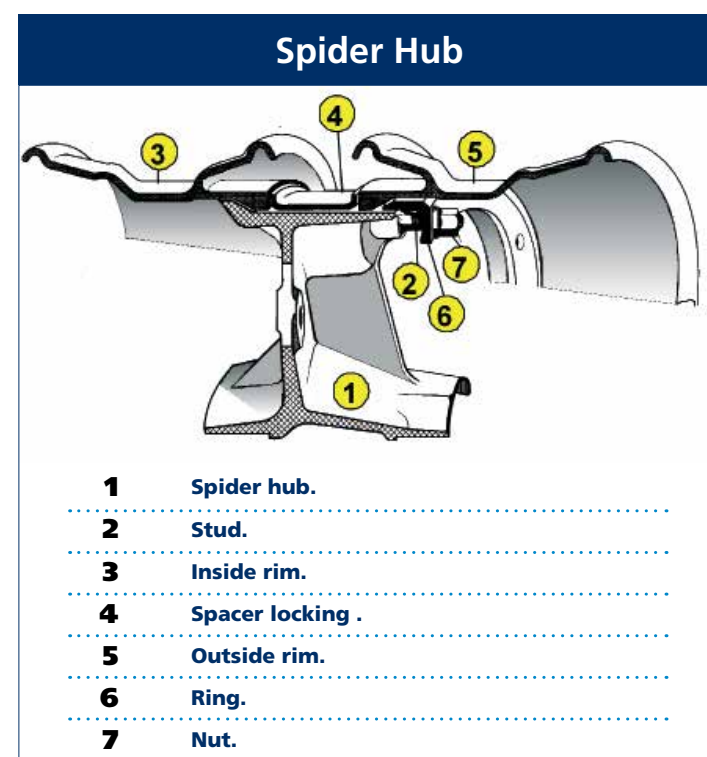

Other factors for transformation

In order to carry out a transformation, other factors to be considered are :

In case of false hub, it should be removed when transforming the wheel into Drop Center (for recent vehicles in 24" Trilex).

Technical features of wheels :

- Whether the vehicle is still under guarantee or not.
- Offset, number of stud holes, diameter of stud holes, diameter of installation and central bore.
- Amount of space available to carry out the transformation.
- Overall width of the vehicle for road use.
- Tread pattern offer (with respect to condition of use) existing in the size of transformation.

Please pay attention, in particular, to transformations with a significant decrease in the rolling circumference of the tyre; this type of transformation may result in a high increase in fuel consumption, and even the premature wearing of tyres due to excessive spinning and sliding.

When transformations make a significant change in the rolling circumference of the tyre, adaptations and new adjustments must be made to the kinematic diagram of the vehicle.

These adaptations can only be made with the agreement and under the responsibility of the local dealer. These adaptations can lead to a modification of bevel gear (extensive modification).

- TYRE KNOWLEDGE AND SAFETY
- INFLATION PRESSURE
- CHECKING THE INFLATION PRESSURE
- EFFECT OF INFLATION PRESSURE ON TYRE MILEAGE
- EFFECT OF INFLATION PRESSURE ON FUEL CONSUMPTION
- THE MICHELIN WARRANTY
- TYRE-USAGE SAFETY PRECAUTIONS AND GUIDELINES
 - PRODUCT LIFE
 - CORRECT MOUNTING AND INFLATION OF TYRES
 - PROPER TYRE REMOVAL
 - CHECKING THE WHEELS
 - REPLACING TYRES
 - CARE OF TYRE
 - REGROOVING
 - RETREADING
 - STORAGE OF TYRES AND TUBES
- TRANSFORMATION OF FLAT RIM TO DROP CENTER
- EQUIVALENT SIZES
- TRUCK TYRE RIMS
- DUAL FITTING AND TYPES OF FIXING
- TRUCK TYRE TUBES AND VALVES
- MOUNTING AND DEMOUNTING
- PROTECTED VALVES ON TUBELESS WHEEL

EQUIVALENT SIZES to convert flat rim to drop center

Theoretical equivalent sizes to convert flat rim to drop center

100 serie	90 serie	Recommended	Low profile serie (Serie <= 80)	Recommended
7.50R15			215/75R17.5	
8.25R15	10R17.5	Yes	235/75R17.5	
10.00R15			285/70R19.5	
7.00R16	8R17.5		205/75R17.5	
7.50R16	8.5R17.5	Yes	215/75R17.5	Yes
8.25R16	10R17.5			
9.00R20	10R22.5	Yes	255/70R22.5 275/70R22.5	
10.00R20	11R22.5	Yes	275/80R22.5	
11.00R20	12R22.5	Yes	295/80R22.5 305/70R22.5	Yes
12.00R20	13R22.5	Yes	315/70R22.5	
			315/80R22.5	Yes
			385/65R22.5	
			385/55R22.5	
14.00R20			525/65R20.5	Yes
16.00R20	24R20.5			

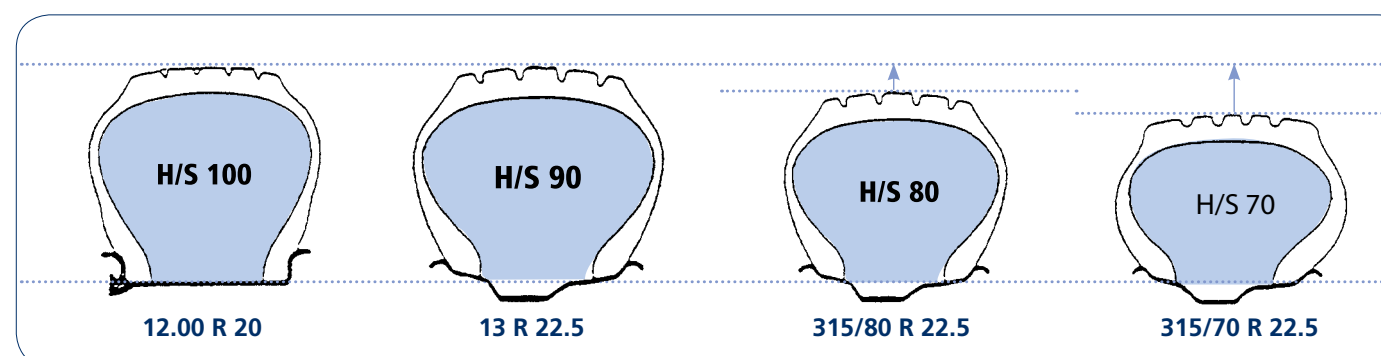

Lower sidewall Solution Advantages

- Better handling
- Good stability of vehicle
- Regular wear
- Outstanding retreadability (80 series)
- Lighter weight

TYRE KNOWLEDGE AND SAFETY

INFLATION PRESSURE

CHECKING THE INFLATION PRESSURE

EFFECT OF INFLATION PRESSURE ON TYRE MILEAGE

EFFECT OF INFLATION PRESSURE ON FUEL CONSUMPTION

THE MICHELIN WARRANTY

TYRE-USAGE SAFETY PRECAUTIONS AND GUIDELINES

PRODUCT LIFE

CORRECT MOUNTING AND INFLATION OF TYRES

PROPER TYRE REMOVAL

CHECKING THE WHEELS

REPLACING TYRES

CARE OF TYRE

REGROOVING

RETREADING

STORAGE OF TYRES AND TUBES

TRANSFORMATION OF FLAT RIM TO DROP CENTER

EQUIVALENT SIZES

TRUCK TYRE RIMS

DUAL FITTING AND TYPES OF FIXING

TRUCK TYRE TUBES AND VALVES

MOUNTING AND DEMOUNTING

PROTECTED VALVES ON TUBELESS WHEEL

TRUCK TYRE RIMS

Main rim characteristics for trucks

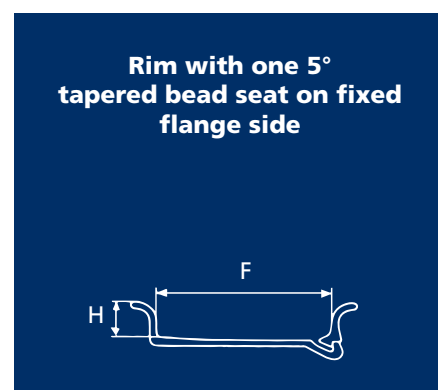

Designation	F mm	H
5.00 R	127	28,6
5.50 S	140	33,3
6.00 S	152	33,3
6.50 T	165	38,1
7.00 T	178	38,1
7.50 V	190	44,4
8.00 V	203	44,4

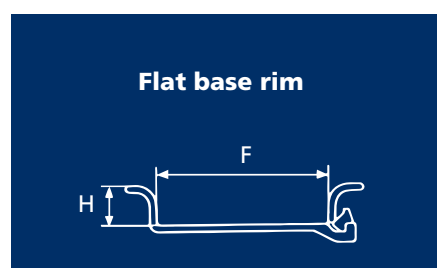

Designation	F mm	H
3.75 P	95	25,4
4.33 R	110	28,6
5.00 S	127	33,3
6.00 T	152	38,1
7.33 V	186	44,4
8.50 V	216	44,4
9.00 V	229	44,4
10.00 V	254	44,4
10.00 W	254	51
11,25	286	51
	286	63,5

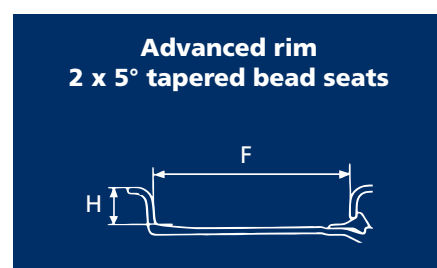

Designation	F mm	H
5.0	127	27,9
5.5	140	30,5
6.0	152	33
6.5	165	35,6
7.0	178	38,1
7.5	190	40,6
8.0	203	43,2
8.5	216	45,7
9.0	229	48,3
10.0	254	50,8

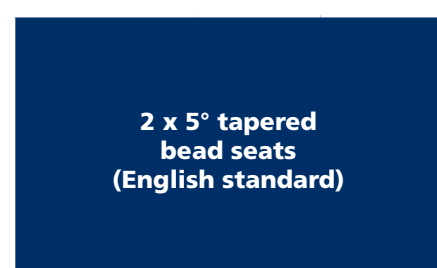

B.5.0	127	27,9
B.5.5	140	27,9
B.6.0	152	33
B.6.5	165	38,1
B.7.0	178	38,1
B.7.5	190	43,2
B.8.0	203	43,2
B.8.5	216	45,7

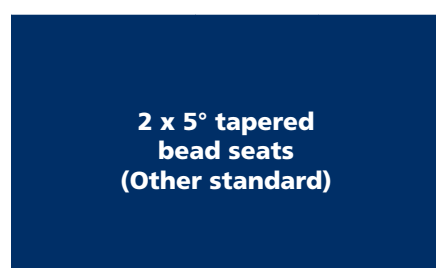

5.0 R	127	28,6
5.5 S	140	33,3
6.0 S	152	33,3
6.5 T	165	38,1
7.0 T	178	38,1
7.5 V	190	44,4
8.0 V	203	44,4
8.5 V	216	44,4
9.0 V	229	44,4
10.0 Wi	254	51

F = Inside width
H = Flange height
 17.5" = 445 mm - 19.5" = 495 mm - 20" = 508 mm - 22.5" = 572 mm - 24" = 609 mm

Other rims

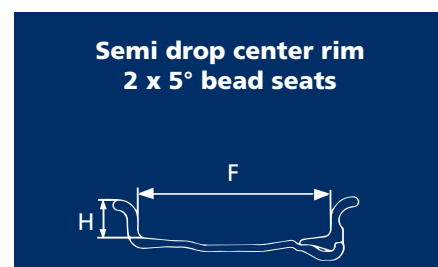

Designation	F mm	H
4.50 E - SDC	114,3	19,8
5.00 E - SDC	127	19,8
5.50 F - SDC	139,7	22,2
6.00 G - SDC	152,4	27,9
6.50 H - SDC	165,1	33,7
7.00 N - SDC	177,8	34,5

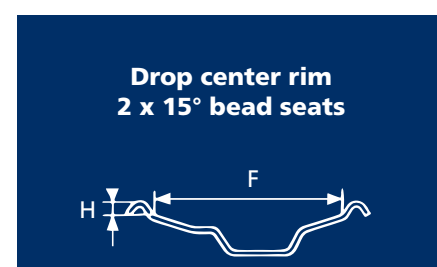

Designation	F mm	H
5.25	133,4	12,7
6.00	152,4	12,7
6.75	171,5	12,7
7.50	190,5	12,7
8.25	209,6	12,7
9.00	228,6	12,7
9.75	247,6	12,7

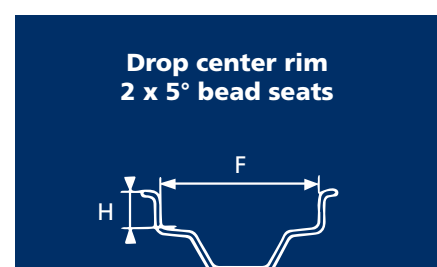

Designation	F mm	H
4.50 E	114,3	19,8
5.00 F	127	22,2
5.50 F	139,7	22,2
5 1/2 K	139,7	19,6
6 L	152,4	21,6
6 1/2 L	165,1	21,6
20 X 5.0 BC	127	25
9 X 20	228,6	26,5
11 X 20	279,4	26,5

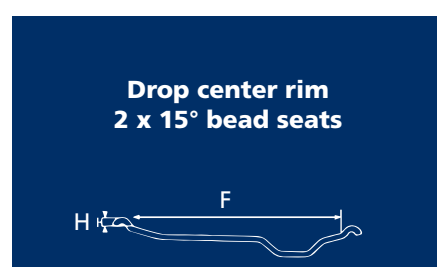

Designation	F mm	H
11.75	298,5	12,7
12.25	311	12,7
13.00	330,2	12,7
14.00	355,6	12,7
15.00	381	12,7
16.00	406,4	12,7
18.00	457	12,7

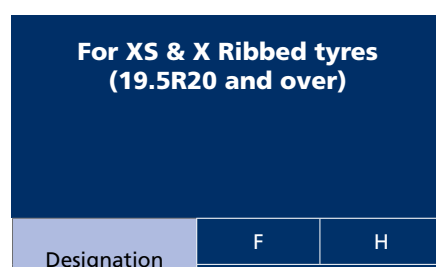

Designation	F mm	H
14.0 x 20	355,6	44,7
18.0 x 21	457,2	38
11.25 x 25/2.0	285,8	50,8
13.00 x 25/2.0	330,2	50,8
13.00 x 25/2.5	330,2	63,5
15.00 x 25/2.5	381	63,5
15.00 x 25/3.0	381	76,2
17.00 x 25/3.0	431,8	76,2

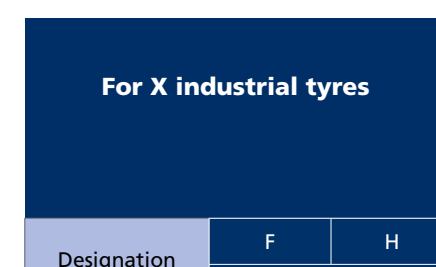

Designation	F mm	H
3.00 D x 8	76,2	17,5
3 1/4 I x 8	82,5	15,7
3 3/4 I x 8	95,2	15,7
4.25 x 8	108	27,1
4.33 R x 8 & 9	110	27,8 or 28,6
4.00 E x 9	101,6	19,8
6.00 E x 9	152,4	19,8
5.00 F x 10	127	22,2
5.50 F x 10	139,7	22,2
6.50 F x 10	165,1	22,2
5.00 S x 12	127	31,3

- TYRE KNOWLEDGE AND SAFETY
- INFLATION PRESSURE
- CHECKING THE INFLATION PRESSURE
- EFFECT OF INFLATION PRESSURE ON TYRE MILEAGE
- EFFECT OF INFLATION PRESSURE ON FUEL CONSUMPTION
- THE MICHELIN WARRANTY
- TYRE-USAGE SAFETY PRECAUTIONS AND GUIDELINES
 - PRODUCT LIFE
 - CORRECT MOUNTING AND INFLATION OF TYRES
 - PROPER TYRE REMOVAL
 - CHECKING THE WHEELS
 - REPLACING TYRES
 - CARE OF TYRE
 - REGROOVING
 - RETREADING
 - STORAGE OF TYRES AND TUBES
- TRANSFORMATION OF FLAT RIM TO DROP CENTER
- EQUIVALENT SIZES
- TRUCK TYRE RIMS
- DUAL FITTING AND TYPES OF FIXING
- TRUCK TYRE TUBES AND VALVES
- MOUNTING AND DEMOUNTING
- PROTECTED VALVES ON TUBELESS WHEEL

DUAL FITTING AND TYPES OF FIXING

Dual fitting for Tube Type wheel and for Tubeless wheel

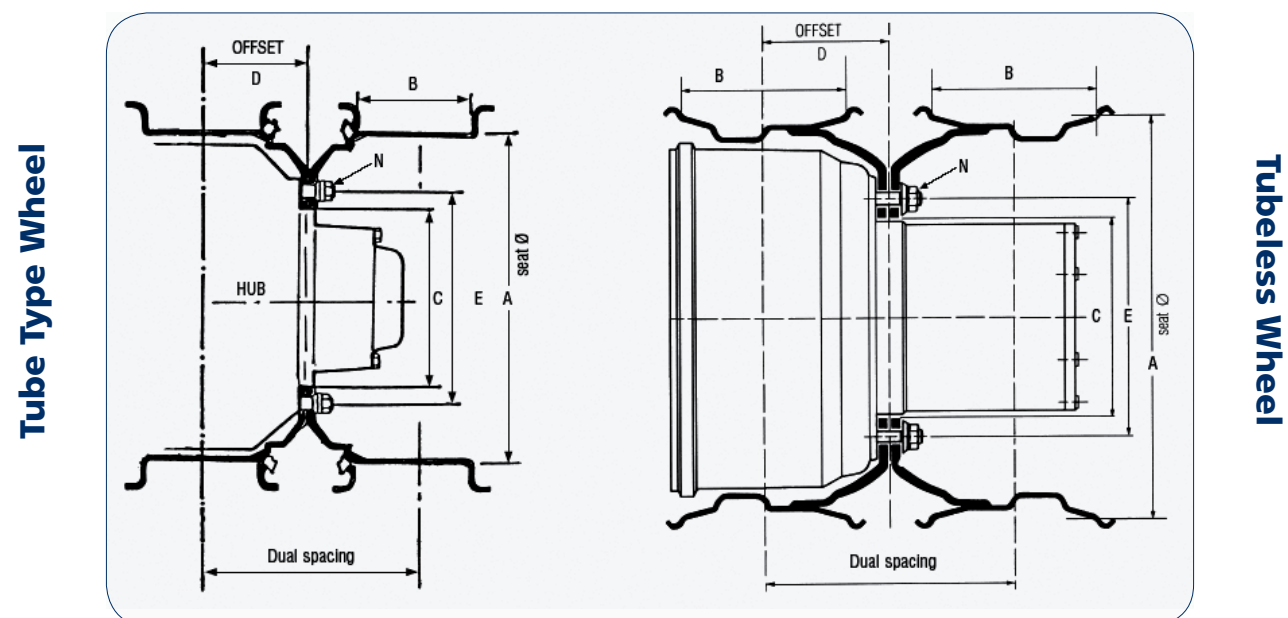

Characteristics

A	Nominal wheel diameter	E	Diameter of the fixing holes.
B	Inside width.	N	Number of fixing holes.
C	Central bore.	Dual Spacing	2 x Offset.
D	Offset.		

Types of fixing

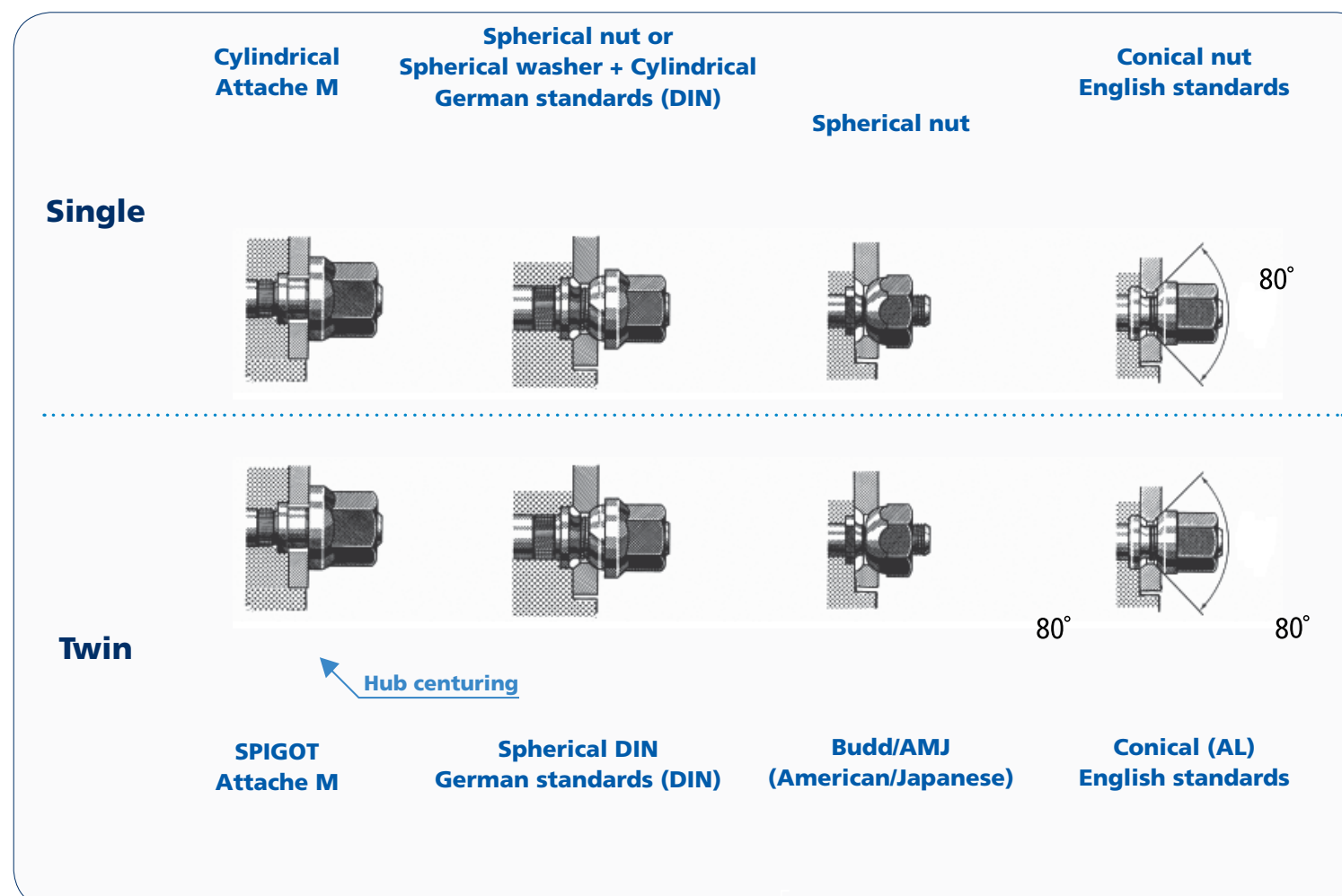

TYRE KNOWLEDGE AND SAFETY

INFLATION PRESSURE

CHECKING THE INFLATION PRESSURE

EFFECT OF INFLATION PRESSURE ON TYRE MILEAGE

EFFECT OF INFLATION PRESSURE ON FUEL CONSUMPTION

THE MICHELIN WARRANTY

TYRE-USAGE SAFETY PRECAUTIONS AND GUIDELINES

PRODUCT LIFE

CORRECT MOUNTING AND INFLATION OF TYRES

PROPER TYRE REMOVAL

CHECKING THE WHEELS

REPLACING TYRES

CARE OF TYRE

REGROOVING

RETREADING

STORAGE OF TYRES AND TUBES

TRANSFORMATION OF FLAT RIM TO DROP CENTER

EQUIVALENT SIZES

TRUCK TYRE RIMS

DUAL FITTING AND TYPES OF FIXING

TRUCK TYRE TUBES AND VALVES

MOUNTING AND DEMOUNTING

PROTECTED VALVES ON TUBELESS WHEEL

TRUCK TYRE TUBES AND VALVES

Tube		Tyre dimensions allowed (on rim)	Valve		
Reference	CAI		Bend Type	Offset mm	Reference
8B	101004	125/75 R 8	Simple	0	1003
8CG	101013	5.00 R 8 - 150/75 R 8	Simple	0	570
8D	101022	180/70 R 8 18-7R8	Simple	0	570
9 F	101040	6.00 R 9 Flat base rim	Simple	0	570
10 F	101049	225/75 R 10 - 6.50/7.50 R 10 Flat base rim	Simple	0	1 012
12 H	101078	7.00 R 12 Flat base rim	Double	0	578
15 K	101126	8.25 R 15 Flat base rim	Double	0	1 221
15 MC9	101363	9.00 R 15 Drop center rim	Straight	25	746
15 P	510204	10.00 R 15 Flat base rim	Triple	0	582
15/16 J	101106	7.50 R 15 Flat base rim	Simple	0	570
15/16 J	101106	205/80 R 15 Flat base rim	Simple	0	570
15/16 J	101106	19 R 400 Drop center and semi drop center rim	Simple	0	570
16 J	101402	7.00 R 16 Semi drop center rim	Simple	0	1 156
16 J	101402	7.50 R 16 Semi drop center rim	Simple	0	1 156
16 J	101402	8.25 R 16 Semi drop center rim	Simple	0	1 156
16 N	101157	9.00 R 16 Semi drop center rim	Double	0	579
16 P	101165	11.00 R 16 Semi drop center rim	Double	0	579
16 P15	101163	9.00 R 16 Drop center rim	Straight	40	611
16 P15	101163	11.00 R 16 Drop center rim	Straight	40	611
19.5 / 20.5 UD	101280	445/65 R 19.5 , 18 R 19;5	Straight	75	1964
19.5 / 20.5 UD	101280	525/65 R 20.5, 20.5 R 20.5	Straight	75	1964
20 H	101099	6.50 R 20 Drop center rim	Simple	0	577
20 J	101119	7.50 R 20 Flat base rim	Simple	0	1 156
20 K	101140	8.25 R 20 Flat base rim	Simple	0	1 021
20 M	101153	9.00 R 20 Flat base rim	Simple	0	1 157
20 N	101161	10.00 R 20 Flat base rim	Simple	0	1 158
20 P	101173	11.00 R 20 Flat base rim	Simple	0	1 158
20 P	101173	E 20 Pilote X -13/80R20 Flat base rim	Simple	0	1 158

Tube		Tyre dimensions allowed (on rim)	Valve		
Reference	CAI		Bend Type	Offset mm	Reference
20 P 15	101167	275/80 R 20 Drop center and semi drop center rim	Straight	40	611
20 P 15	101167	335/80 R 20 Drop center and semi drop center rim	Straight	40	611
20PD	101177	335/80 R 20	Straight	29	1964
20PD	101177	12.5 R 20	Straight	29	1964
20PD	101178	335/80 R 20	Straight	29	750
20PD	101178	12.5 R 20	Straight	29	750
20 Q	101192	12.00 R 20 Flat base rim	Simple	0	1 158
20 Q	101192	F 20 Pilote Flat base rim	Simple	0	1 158
20 S	101192	365/80 R 20 Drop center and semi drop center rim	Simple	0	1 158
20 R 15	101198	425/75 R 20 Drop center and semi drop center rim	Straight	55	611
20 RD	101394	375/75 R 20 Drop center and semi drop center rim	Simple	40	750
20 RD	101394	405/70 R 20 Drop center and semi drop center rim	Simple	40	750
20 S	101222	14.00 R 20 Flat base rim	Triple	0	582
20 S	101222	14.5 R 20 Drop center and semi drop center rim	Triple	0	582
20 S	101222	G 20 Flat base rim	Triple	0	582
20 S	101222	13.00 R 20 Pilote Flat base rim	Triple	0	582
20 S	101222	365/85 R 20 Flat base rim	Triple	0	582
20 S	101222	395/85 R 20 Flat base rim	Triple	0	582
20U	101283	475/80 R 20 Flat base rim	Simple	0	1 188
20 V	511937	16.00 R 20 Flat base rim	Simple	0	1 188
20 V	511937	425/75 R 20 Drop center and semi drop center rim	Simple	0	1 188
20.5 WAMD	101331	24 R 20.5	Simple	100	1 837
24P	512750	E24 Flat base rim	Triple	0	582
24 Q	101196	12.00 R 24 & 325/95 R 24 Flat base rim	Triple	0	582
24 RD	101196	12.00 R 24 Drop center and semi drop center rim	Triple	0	577
24TD	101244	14.00 R 24 Drop center and semi drop center rim	Simple	0	577
24/25TAM	101781	14.00 R 24 Flat base rim	Simple	0	1837
24/25T	514503	13.00 et 14.00 R 25 Flat base rim	Simple	0	752

TYRE KNOWLEDGE AND SAFETY

INFLATION PRESSURE

CHECKING THE INFLATION PRESSURE

EFFECT OF INFLATION PRESSURE ON TYRE MILEAGE

EFFECT OF INFLATION PRESSURE ON FUEL CONSUMPTION

THE MICHELIN WARRANTY

TYRE-USAGE SAFETY PRECAUTIONS AND GUIDELINES

PRODUCT LIFE

CORRECT MOUNTING AND INFLATION OF TYRES

PROPER TYRE REMOVAL

CHECKING THE WHEELS

REPLACING TYRES

CARE OF TYRE

REGROOVING

RETREADING

STORAGE OF TYRES AND TUBES

TRANSFORMATION OF FLAT RIM TO DROP CENTER

EQUIVALENT SIZES

TRUCK TYRE RIMS

DUAL FITTING AND TYPES OF FIXING

TRUCK TYRE TUBES AND VALVES

MOUNTING AND DEMOUNTING

PROTECTED VALVES ON TUBELESS WHEEL

MOUNTING - DEMOUNTING

Rubber truck tyres base valves

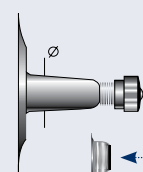

Plastic ferrule for the fitment of valve 746 in 15.7 mm diameter hole

Reference		Ø hole of the valve
ETRTO	MICHELIN	
V2-01-1	746	11,3
V2-01-2	611	15,7
—	990	15,7

Base for Truck valve stems

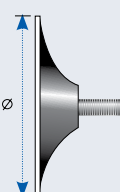

Reference		Ø
ETRTO	MICHELIN	
V3-08-4	1548	57

Single bend valve stem

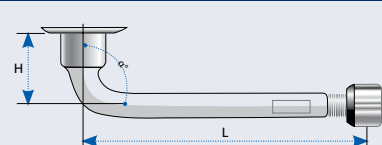

Reference		L mm	H mm	α°
ETRTO	MICHELIN			
V3-02-2	570	43	22	120
V3-02-3	576	44	33	95
V3-02-4	577	44	39	110
V3-02-5	1003	47	20	90
V3-02-7	1188	71	22	100
V3-02-9	1156	99	20	94
V3-02-10	1021	115	20	94
V3-02-12	1157	132	20	94
V3-02-13	751	133	20	90
V3-02-14	1158	138	20	94
V3-02-20	750	53	22	95
V3-02-23	1012	66	29	90
V3-03-4	1010	84	15	94

Valve with straight stem

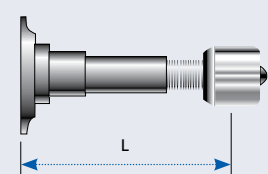

Reference		L mm
ETRTO	MICHELIN	
—	1964	49

Double bend valve stem

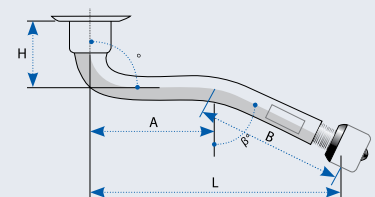

Reference		L mm	A mm	B mm	H mm	α°	β°
ETRTO	MICHELIN						
V3-04-1	578	60	32	37	20	90	138
V3-04-2	579	76	38	41	20	90	153
V3-04-6	734	128	86	47	20	90	153
V3-04-8	1198	80	38	43	20	90	167
V3-04-26	1877	140	99	42	20	99	189
V3-05-1	1221	96	32	66	16	90	165

Triple bend valve stem

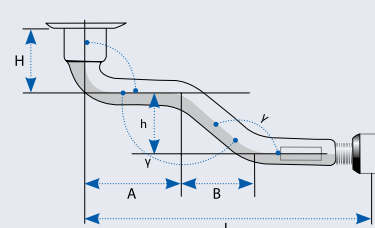

Reference		L mm	A mm	B mm	H mm	h mm	α°	β°
ETRTO	MICHELIN							
V3-06-2	580	94	44	12	20	17	90	125
V3-06-3	581	114	46	20	20	17	90	140
V3-06-5	582	131	62	19	20	17	90	139
V3-06-7	1348	106	45	18	20	17	90	137

Mounting a universal valve stem

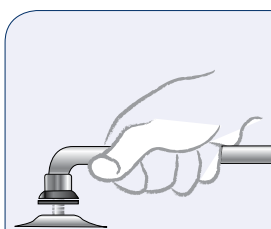

1. Fit the air-tight rubber which must be dry and clean.
2. Screw down the stem until contact is made with the washer.
3. To ensure air-tightness, screw two complete turns.
4. Tighten the stem further until the final position is correct.

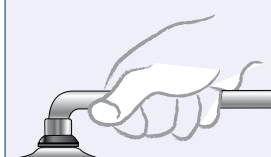

IMPORTANT : do not unscrew.

NB : Do not screw up tighter than recommended above. Do not forget to fit the valve cap which keeps it clean and helps keep the valve leakproof.

Essential accessories

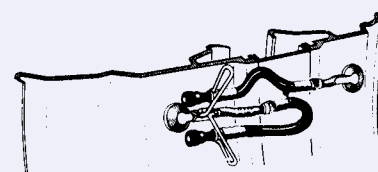

Truck Tyre valve extension

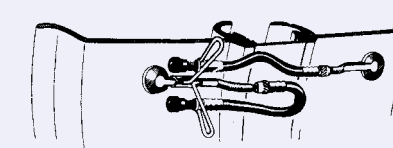

In these assemblies, always fit the valves facing each other.

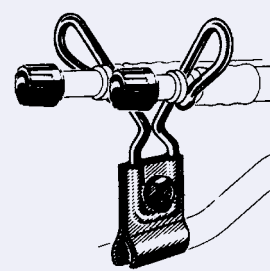

Fixing Clamps for Trucks Tyres valve extension

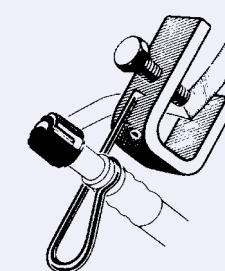

When tyres are twinned, in order to avoid abnormal wear and tyre overload problems, it is essential to ensure that twinned tyres are the same size, same manufacture, same type and tread pattern, and that the wear rates and pressures are the same. Valve extensions fitted to inner twins, permit easy verification of tyre pressures. It is essential to ensure that they are correctly fitted, and supported with the appropriate brackets where necessary.

TYRE KNOWLEDGE AND SAFETY

INFLATION PRESSURE

CHECKING THE INFLATION PRESSURE

EFFECT OF INFLATION PRESSURE ON TYRE MILEAGE

EFFECT OF INFLATION PRESSURE ON FUEL CONSUMPTION

THE MICHELIN WARRANTY

TYRE-USAGE SAFETY PRECAUTIONS AND GUIDELINES

PRODUCT LIFE

CORRECT MOUNTING AND INFLATION OF TYRES

PROPER TYRE REMOVAL

CHECKING THE WHEELS

REPLACING TYRES

CARE OF TYRE

REGROOVING

RETREADING

STORAGE OF TYRES AND TUBES

TRANSFORMATION OF FLAT RIM TO DROP CENTER

EQUIVALENT SIZES

TRUCK TYRE RIMS

DUAL FITTING AND TYPES OF FIXING

TRUCK TYRE TUBES AND VALVES

MOUNTING AND DEMOUNTING

PROTECTED VALVES ON TUBELESS WHEEL

PROTECTED VALVE ON TUBELESS WHEEL

General Note

European truck manufacturers have introduced a protected valve wheel, known as external valve hole (EVH truck wheel).

The wheel incorporate a «safety hump» tyre bead seat, making it very difficult to unseat, or «break» the tyre bead.

This safety hump is present on all drop center wheels.

Without a dismounting machine, a special tool is needed to carry out this bead breaking operation to reduce the risk of damaging the tyre bead.

Different tool models are available on the market.



Disc Brake with Standard Wheel

With a disc brake the valve can be damaged if a foreign object is trapped between the valve and the clipper, consequently the tyre mat become flat.

A = Rotating parts
B = Fix Calliper

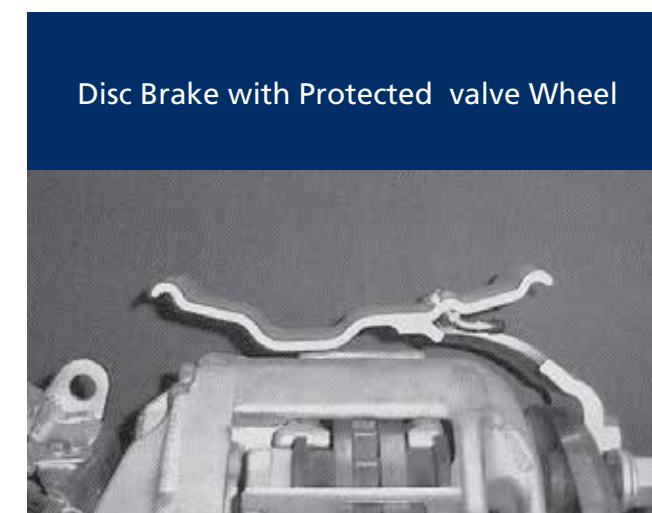

Disc Brake with Protected valve Wheel

With a protected valve wheel, the valve is protected as it is located outside of the disc wheel.

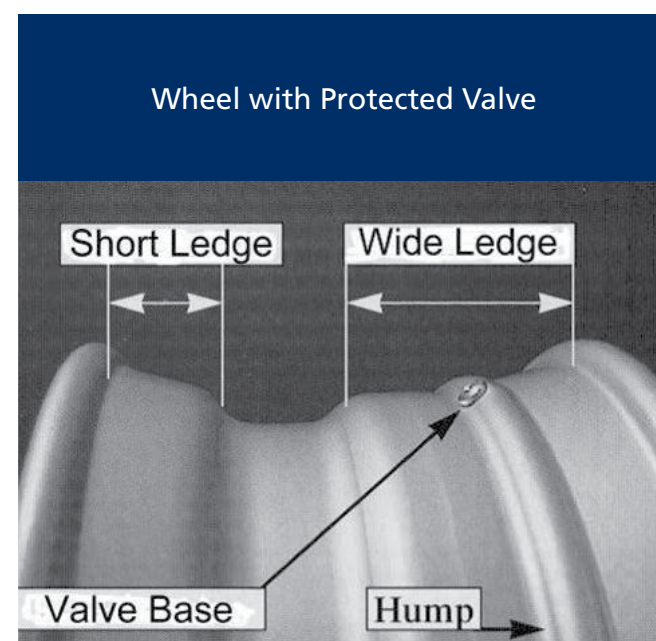

Short Ledge / Wide Ledge / Valve Base / Hump



Screw lever / Carrying handle / Thickness wedge - inside / Stabiliser / Spade / Fixture on rim

TYRE KNOWLEDGE AND SAFETY

INFLATION PRESSURE

CHECKING THE INFLATION PRESSURE

EFFECT OF INFLATION PRESSURE ON TYRE MILEAGE

EFFECT OF INFLATION PRESSURE ON FUEL CONSUMPTION

THE MICHELIN WARRANTY

TYRE-USAGE SAFETY PRECAUTIONS AND GUIDELINES

PRODUCT LIFE

CORRECT MOUNTING AND INFLATION OF TYRES

PROPER TYRE REMOVAL

CHECKING THE WHEELS

REPLACING TYRES

CARE OF TYRE

REGROOVING

RETREADING

STORAGE OF TYRES AND TUBES

TRANSFORMATION OF FLAT RIM TO DROP CENTER

EQUIVALENT SIZES

TRUCK TYRE RIMS

DUAL FITTING AND TYPES OF FIXING

TRUCK TYRE TUBES AND VALVES

MOUNTING AND DEMOUNTING

PROTECTED VALVES ON TUBELESS WHEEL

VEHICLE AND TYRE DIAGNOSTICS

1) When performing tyre diagnosis

- Make, model & engine vehicle capacity
- Inflation pressures
- Nature and conditions of road used
- Driving style
- Loads carried



2) Examine the tyre:

- Tread
- Sidewalls
- Bead
- Tyre interior



3) Check the rim, the valve, the valve extensions, the tube, the sealing ring and vehicle:



VEHICLE AND TYRE DIAGNOSTICS

ALIGNMENT ANGLES

ALIGNMENT, PARALLELISM, TANDEM AXLE PARALLELISM & CAMBER

CASTER, TOE-OUT ON TURNS (TURNING RADIUS) & PERIODIC ALIGNMENT CHECKS

TYRE DAMAGE DIAGNOSIS

FEATHER, HEEL AND TOE, SLOPED, CENTRE, WAVY LUMPY & ROUDED WEAR

SHOULDER, TRAMLIN, SHOULDER SECTION, BRAKE SPOT, CROWN IMPACT, DETACHMENT & OF THE CROWN

RUPTURE OF THE CASING PLY, IMPACT / PINCHING, MARBLING, DISLOCATION, BEAD DAMAGE & MULTIPLE CUTS

ALIGNMENT ANGLES

Many tyre problems can be traced to mechanical conditions in the vehicle. Therefore, to obtain maximum tyre performance, vehicles must be properly maintained.

ALIGNMENT

Alignment refers not only to the various angles of the steer axle geometry, but also to the tracking of all axles on a vehicle, including the trailer. The dual purpose of proper alignment is to minimize tyre wear to maximize predictable vehicle handling and driver control. Toe misalignment is the number one cause of steer tyre irregular wear, followed by rear axle skew. One of the challenges of meeting this goal is that alignments are typically performed on a static, unloaded vehicle sitting on a level floor.

All these misalignment conditions may exist alone or (more likely) in combination with other misalignment conditions.

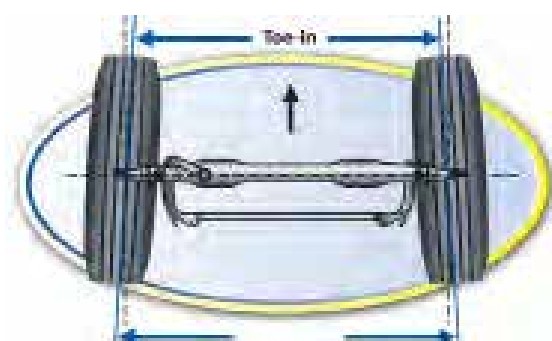

PARALLELISM

Toe is typically the most critical alignment condition affecting steer axle tyre wear. The purpose of setting toe at a given specification is to allow the tyre to run straight during normal operating conditions. Too much Toe-In results in scrubbing from the outside inward on both tyres and too much Toe-Out results in scrubbing the inside outward on both tyres. Total toe is the angle formed by two horizontal lines through the planes of two wheels.

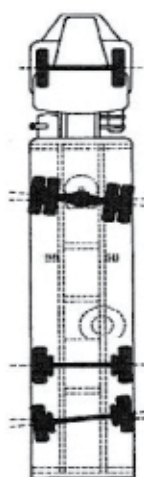

Typical commercial vehicles require a slight amount of Toe-In with 1-2mm set on a static unloaded vehicle so that tyres will have zero toe or straight ahead when the vehicle is loaded and operating on the road.



TANDEM AXLE PARALLELISM (SKEW/THRUST)

Tandem Axle Parallelism is critical because it can have a detrimental effect on all tyres on the vehicle. Non parallel drive axles tend to push the vehicle into a turn in the direction that the axle ends are closest. In order for the vehicle to go straight, the driver must correct by steering in the opposite direction.

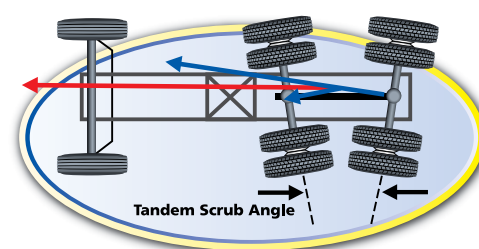

The vehicle can then go straight, but all tyres are at an angle to the direction of travel, causing scrubbing. Excessive rear axle non parallelism is usually detected in steer tyre wear. If one steer tyre is scrubbing from the outside inward and the other steer tyre is scrubbing from the inside outward, then tandem axle alignment is suspect.



A similar pattern can be generated by the driver's compensation for non lubricated 5th wheel or from a dog tracking trailer. Misalignment of tandem axles greater than 3mm(0.10degrees) can lead to uneven and rapid tyre wear.

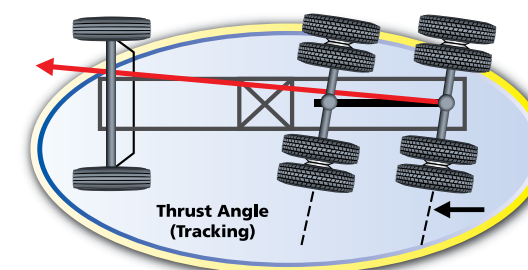

CAMBER

Camber is angle formed by the inward or outward tilt of the wheel referenced to a vertical line.

VEHICLE AND TYRE DIAGNOSTICS

ALIGNMENT ANGLES

ALIGNMENT, PARALLELISM, TANDEM AXLE PARALLELISM & CAMBER

CASTER, TOE-OUT ON TURNS (TURNING RADIUS) & PERIODIC ALIGNMENT CHECKS

TYRE DAMAGE DIAGNOSIS

FEATHER, HEEL AND TOE, SLOPED, CENTRE, WAVY LUMPY & ROUDED WEAR

SHOULDER, TRAMLIN, SHOULDER SECTION, BRAKE SPOT, CROWN IMPACT, DETACHMENT & OF THE CROWN

RUPTURE OF THE CASING PLY, IMPACT / PINCHING, MARBLING, DISLOCATION, BEAD DAMAGE & MULTIPLE CUTS

ALIGNMENT ANGLES

Many tyre problems can be traced to mechanical conditions in the vehicle. Therefore, to obtain maximum tyre performance, vehicles must be properly maintained.

1. Camber is positive when the wheel is tilted outward at the top.
2. Camber is negative when the wheel is tilted inward at the top.
3. Excessive positive camber may cause smooth wear on the outer half of the tyre tread.

Camber is often a contributor to wear occurring on the interior ribs/blocks of the inner twin drive and trailer tyres, and can sometimes affect the interior ribs/blocks of the outer dual as well. Overloading of the axle leads to excessive negative camber and wear on the inside shoulder of the tyre.

Camber correction by bending axles is NOT RECOMMENDED by MICHELIN. Consult the axle manufacturer if camber is found to be incorrect (outside manufacturer specification).

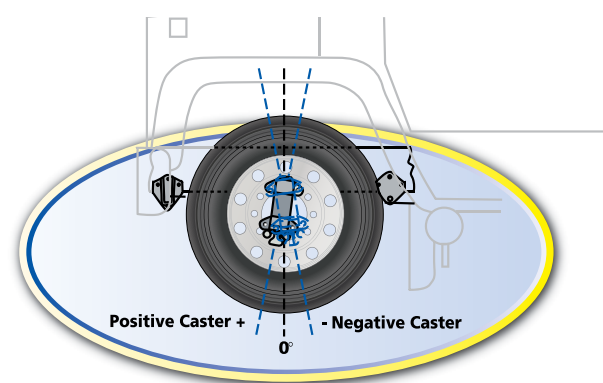
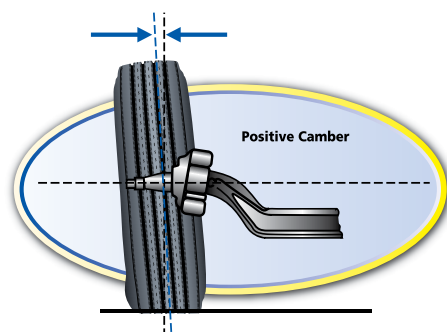

CASTER

Positive (+) caster is the backward tilt at the top of the kingpin when viewed from the side. Negative caster is the forward tilt of the top at the kingpin when viewed from the side. The purpose of caster is to provide self-aligning forces on the steer tyres to stabilize the vehicle when driving straight down the road under braking, free wheeling, and power conditions. Insufficient caster reduces stability and can cause wander. Excessive caster increases steering effort and can cause shimmy. Either of these conditions may also have a detrimental effect on tyre wear. Excessive caster beyond the vehicle manufacturer's specifications may result in induced camber causing excessive tyre wear, particularly fleets that are in local and regional

operations. Caster is adjustable with shims. Adjusting only one side is not recommended. Caster on both sides should be equal or not more than one-half degree difference. Generally, the vehicle will pull to the side with the least amount of positive caster. Typical values on modern vehicles range from 2 to 5 degrees positive caster.

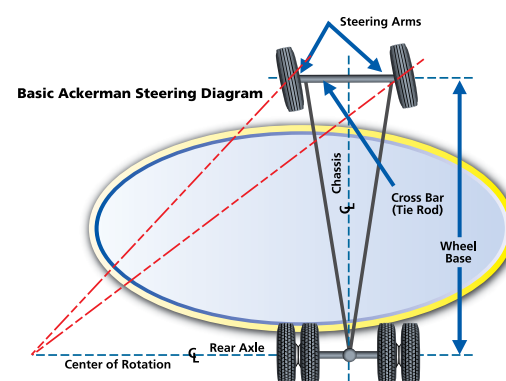

TOE-OUT ON TURNS (TURNING RADIUS)

Toe-out on turns is the difference in the arcs described by the steering tyres in a turn. The purpose is to prevent the inside tyre from scrubbing around a turn since the outside tyre (loaded tyre) determines the turning radius of the steer axle. Improper geometry results in a tyre scrub in turns, which generally appears as toe wear on the tyre.

PERIODIC ALIGNMENT CHECKS

Verification of proper axle geometry and alignment should be part of the overall routine vehicle maintenance program.

Specific alignment angle settings and tolerances should match the recommendations of the vehicle manufacturer. Suggested periodic checks include the following:

*New vehicles prior to placing into services and again after some period where the new components have settled after running some kilometers. Verification of proper torque on the suspension system fasteners can also be done at this time. Follow the recommendations of the vehicle manufacturer.

*When tyres are noted to have uneven wear which suggests misalignment.

*When any steering or suspension component such as leaf springs as replaced.

- * Excessive negative camber may cause wear on the inner half of the tread.
- * Negative camber can also be a cause inside shoulder wear on trailer axle in dual or single configuration.
- * A free rolling tyre is more sensitive to camber than a driven tyre.
- * Generally, the vehicle will pull to the side with the most amount of positive camber. (If difference is more than 1/2 degree)
- * Typical camber values for a static, unloaded vehicle are zero plus or minus one-half a degree (-0.5 to +0.5 degree).



VEHICLE AND TYRE DIAGNOSTICS

ALIGNMENT ANGLES

ALIGNMENT, PARALLELISM, TANDEM AXLE PARALLELISM & CAMBER

CASTER, TOE-OUT ON TURNS (TURNING RADIUS) & PERIODIC ALIGNMENT CHECKS

TYRE DAMAGE DIAGNOSIS

FEATHER, HEEL AND TOE, SLOPED, CENTRE, WAVY LUMPY & ROUDED WEAR

SHOULDER, TRAMLIN, SHOULDER SECTION, BRAKE SPOT, CROWN IMPACT, DETACHMENT & OF THE CROWN

RUPTURE OF THE CASING PLY, IMPACT / PINCHING, MARBLING, DISLOCATION, BEAD DAMAGE & MULTIPLE CUTS

TYRE DAMAGE DIAGNOSIS

SAFETY IS OUR TOP PRIORITY. LOOK OUT FOR ANY SIGNS OF WEAR BEFORE GETTING IN TO THE VEHICLE.



Feather wear

SIGNS

Presence of feathering at the edge of the tread blocks, more evident on one side than the other.

PROBABLE CAUSES

Scuffing whilst running, caused by incorrect alignment of the wheels (toeing in or toeing out) or axle misalignment.

ADVICE

- **Tyre:** Can be kept on the vehicle if it meets legal requirements.
- **Vehicle:** Adjust vehicle geometry (parallelism alignment) according to vehicle manufacturer's specifications.



Sloped wear

SIGNS

Smooth and regular wear sloping from one side to another without feathering.

PROBABLE CAUSES

Excessive wheel camber. Flexing of the axle under the weight of the load. (This is more pronounced on the inner tyre of a twinned assembly).

ADVICE

- **Tyre:** Turn on the rim. Check pressures when tyre is cold and alter as necessary.
- **Vehicle:** Check the vehicle geometry. Check the load is distributed evenly across the axle.



Heel and toe wear

SIGNS

Occurring mainly on tyres with block type treads. The leading edge of each block is sharply defined, with the trailing edge excessively worn.

PROBABLE CAUSES

- 1) The forces exerted on the tyre from increasingly powerful accelerating and braking torques. (Affected by application, frequent stopping and surface texture).
- 2) Inappropriate inflation pressures for the load carried by the tyre.

ADVICE

- **Tyre:** Check the pressure when the tyre is cold and adjust it if necessary. It may be possible to keep the tyre on the vehicle if legal requirements are met. Permutate the tyres to even out wear.
- **Vehicle:** Nothing.



Centre wear

SIGNS

Wear more pronounced in the centre of the tread than on the shoulders.

PROBABLE CAUSES

Overinflation.

ADVICE

- **Tyre:** Check the inflation pressures when tyres are cold and re-established according to manufacturer's recommendations related to the conditions of use.
- **Vehicle:** Nothing

VEHICLE AND TYRE DIAGNOSTICS

ALIGNMENT ANGLES

ALIGNMENT, PARALLELISM, TANDEM AXLE PARALLELISM & CAMBER

CASTER, TOE-OUT ON TURNS (TURNING RADIUS) & PERIODIC ALIGNMENT CHECKS

TYRE DAMAGE DIAGNOSIS

FEATHER, HEEL AND TOE, SLOPED, CENTRE, WAVY LUMPY & ROUDED WEAR

SHOULDER, TRAMLINE, SHOULDER SECTION, BRAKE SPOT, CROWN IMPACT, DETACHMENT & OF THE CROWN

RUPTURE OF THE CASING PLY, IMPACT / PINCHING, MARBLING, DISLOCATION, BEAD DAMAGE & MULTIPLE CUTS

TYRE DAMAGE DIAGNOSIS

SAFETY IS OUR TOP PRIORITY. LOOK OUT FOR ANY SIGNS OF WEAR BEFORE GETTING IN TO THE VEHICLE.

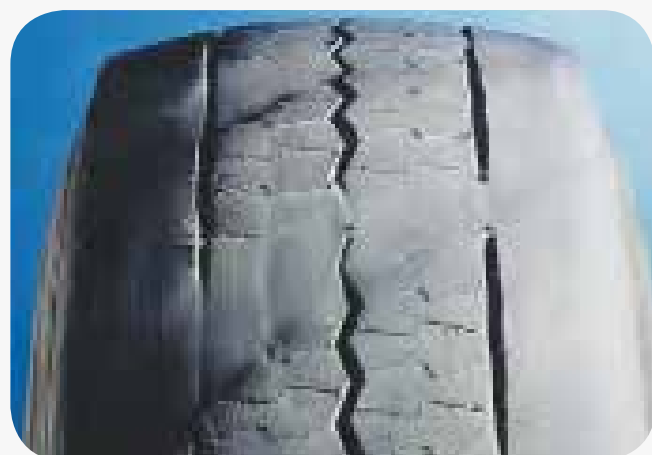

Wavy lumpy wear

SIGNS

Wavy wear affecting half or more of the tread

PROBABLE CAUSES

- Wear or play in the suspension or steering systems
- Imbalance, incorrect fitting
- Incorrect twinning (wear rate, different tyre brands...)
- Twins with different inflation pressures
- Severe pitching of the vehicle
- Heavy loads and a high centre of gravity.

ADVICE

- **Tyre:** Check fitting and inflation pressure (adjust for conditions of use). Check twin tyres: Meets legal requirements.
- **Vehicle:** Check and if necessary repair the suspension and steering systems.



Shoulder wear

SIGNS

Circumferential wear to one shoulder, where shoulder is partially or completely worn away.

PROBABLE CAUSES

Severe pitching of the vehicle, perhaps due to high centre of gravity. Prolonged running at a pressure which is inappropriate for the load or use.

ADVICE

- **Tyre:** Check and adjust pressures according to the conditions of use.
- **Vehicle:** Nothing.



Rounded wear

SIGNS

Wear more pronounced on shoulders than in the centre of the tread.

PROBABLE CAUSES

Tyre underinflated or overloaded.

ADVICE

- **Tyre:** Find the cause of the underinflation and resolve it. (Start by checking for pressures, punctures, valve caps, valve stems etc.) Weigh each axle of the loaded vehicle and adjust the pressures accordingly. It may be possible to keep the tyre on the vehicle if legal requirements are met.
- **Vehicle:** Nothing.



Shoulder Step Wear

APPEARANCE

Partial or full depression of the inside or outside shoulder tread rib

PROBABLE CAUSES

This condition is common on radial tyres in slow wearing applications

CORRECTIVE ACTION

None

TYRE DISPOSITION

Can continue to run if minimum tread depth is not reached. Rotate or retread

VEHICLE AND TYRE DIAGNOSTICS

ALIGNMENT ANGLES

ALIGNMENT, PARALLELISM, TANDEM AXLE PARALLELISM & CAMBER

CASTER, TOE-OUT ON TURNS (TURNING RADIUS) & PERIODIC ALIGNMENT CHECKS

TYRE DAMAGE DIAGNOSIS

FEATHER, HEEL AND TOE, SLOPED, CENTRE, WAVY LUMPY & ROUDED WEAR

SHOULDER, TRAMLIN, SHOULDER SECTION, BRAKE SPOT, CROWN IMPACT, DETACHMENT & OF THE CROWN

RUPTURE OF THE CASING PLY, IMPACT / PINCHING, MARBLING, DISLOCATION, BEAD DAMAGE & MULTIPLE CUTS

TYRE DAMAGE DIAGNOSIS

SAFETY IS OUR TOP PRIORITY. LOOK OUT FOR ANY SIGNS OF WEAR BEFORE GETTING IN TO THE VEHICLE.



Shoulder section wear

SIGNS

Wear to the shoulder section (less than half the tread).

PROBABLE CAUSES

Pressure unsuitable for load.

- Considerable sway.

A lot of play in the suspension is an aggravating factor.

ADVICE

• **Tyre:**

Check and adjust pressures.

• **Vehicle:**

Check suspension and load conditions (whether load can shift, etc.).



Brake Spot

SIGNS

Very localised wear, the size and shape of which resembles that of the contact patch.

Possible presence of circumferential scratches and cuts to the rubber.

The other tyre of the same axle has often the same signs.

PROBABLE CAUSES

Locking of the wheel(s) caused by excessive braking or defects to the braking system.

ADVICE

• **Tyre:**

Remove from vehicle according to severity.

• **Vehicle:**

Check the braking system if the localised wear is not attributable to excessive braking.



Crown impact

SIGNS

Localised tread cut with rupture of the crown reinforcing plies.

The rupture is often accompanied by a sidewall deformation.

PROBABLE CAUSES

Severe impact with a fixed obstacle (kerb, rock, pothole) causing the crown plies to be severely deformed, creased or ruptured. This type of damage is more likely when the tyre is overinflated.

ADVICE

• **Tyre:**

Inflate to the correct pressure.

Avoid overloading.

• **Vehicle:**

Reduce speed in case of overloading, high pressures on damaged roads.



Detachment of the crown

SIGNS

Detachment of the crown plies which can eventually lead to complete disintegration of the structure of the tyre.

PROBABLE CAUSES

Prolonged use in an underinflated and /or overloaded condition causing abnormal heat build up in the crown area.

ADVICE

• **Tyre:**

Regularly check pressures.

Avoid overloading.

• **Vehicle:**

Nothing.

VEHICLE AND TYRE DIAGNOSTICS

ALIGNMENT ANGLES

ALIGNMENT, PARALLELISM, TANDEM AXLE PARALLELISM & CAMBER

CASTER, TOE-OUT ON TURNS (TURNING RADIUS) & PERIODIC ALIGNMENT CHECKS

TYRE DAMAGE DIAGNOSIS

FEATHER, HEEL AND TOE, SLOPED, CENTRE, WAVY LUMPY & ROUDED WEAR

SHOULDER, TRAMLINE, SHOULDER SECTION, BRAKE SPOT, CROWN IMPACT, DETACHMENT & OF THE CROWN

RUPTURE OF THE CASING PLY, IMPACT / PINCHING, MARBLING, DISLOCATION, BEAD DAMAGE & MULTIPLE CUTS

TYRE DAMAGE DIAGNOSIS

SAFETY IS OUR TOP PRIORITY. LOOK OUT FOR ANY SIGNS OF WEAR BEFORE GETTING IN TO THE VEHICLE.



Rupture of the casing ply

SIGNS

Regular circumferential rupture to the sidewall.

PROBABLE CAUSES

- Prolonged running with inadequate inflation pressure.
- Prolonged running overloaded.
- Running with different pressures on twins.
- Poor twinning: wear, dimension, brand vehicle, etc.

ADVICE

• **Tyre:**

Inflate to the correct pressures, avoid overloading, check twinned tyres.

• **Vehicle:**

Nothing.

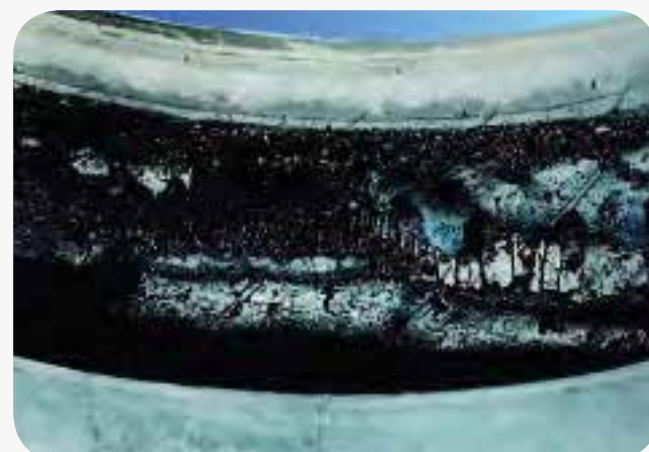

Dislocation

SIGNS

Dislocation and holes in the interior lining, even ending in complete dislocation and rupture of the casing

PROBABLE CAUSES

Prolonged running underinflated or overloaded.

ADVICE

• **Tyre:**

Remove tyre from vehicle and scrap.

Inflate replacement tyres to correct pressure.

Check the pressures regularly. Find out why the pressures were low (puncture, valve, rim etc).

• **Vehicle:**

Nothing.



Impact / pinching

SIGNS

Rupture of the cables with cuts to sidewall rubber.

PROBABLE CAUSES

Severe impact on an obstacle (kerb, stones, holes) causing the sidewall to be pinched between the rim and the obstacle.

This type of damage is more likely when the tyre is underinflated or overloaded.

ADVICE

• **Tyre:**

Remove from the vehicle and hand over to a specialist for possible repair after thorough investigation.

• **Vehicle:**

Nothing.



Bead damage

SIGNS

Damage to the bead point or the 'heel' caused during fitting or removal.

PROBABLE CAUSES

Poor use of fitting and removal tools, or tools in poor condition.

ADVICE

• **Tyre:**

Remove tyre from service and dispose of it.

Follow all fitting and removal instructions carefully.

Ensure all tools are in good condition.

• **Vehicle:**

Nothing.

VEHICLE AND TYRE DIAGNOSTICS

ALIGNMENT ANGLES

ALIGNMENT, PARALLELISM, TANDEM AXLE PARALLELISM & CAMBER

CASTER, TOE-OUT ON TURNS (TURNING RADIUS) & PERIODIC ALIGNMENT CHECKS

TYRE DAMAGE DIAGNOSIS

FEATHER, HEEL AND TOE, SLOPED, CENTRE, WAVY LUMPY & ROUDED WEAR

SHOULDER, TRAMLIN, SHOULDER SECTION, BRAKE SPOT, CROWN IMPACT, DETACHMENT & OF THE CROWN

RUPTURE OF THE CASING PLY, IMPACT / PINCHING, MARBLING, DISLOCATION, BEAD DAMAGE & MULTIPLE CUTS

TYRE DAMAGE DIAGNOSIS

SAFETY IS OUR TOP PRIORITY. LOOK OUT FOR ANY SIGNS OF WEAR BEFORE GETTING IN TO THE VEHICLE.



Marbling

SIGNS

Presence of marbling and creasing of the interior lining in the flexion zone.

PROBABLE CAUSES

Running underinflated or overloaded.

ADVICE

• **Tyre:**

Remove tyre from vehicle and scrap.

Important: Never reinflate a tyre that has been running underinflated without first removing it and examining the interior.

• **Vehicle:**

Nothing



Multiple cuts

SIGNS

Multiple cuts all around the tread.

PROBABLE CAUSES

Running on coarse surfaces, sites and quarries.

Overinflation and damp surfaces exacerbate this type of damage.

ADVICE

• **Tyre:**

Use the correct tyre for the application. Ensure correct pressures.

• **Vehicle:**

Nothing.



Tramline wear

SIGNS

An area of more or less circumferential wear affecting only part of tread width.

PROBABLE CAUSES

Undemanding usage on straight roads and motorways (sign of slow wear rate).

ADVICE

• **Tyre:**

Ensure the appropriate tyre for the application is being used.

Tyre may be kept on the vehicle if legal requirements are met and handling is not affected. Check pressures and permutate if appropriate.

• **Vehicle:**

Nothing.

VEHICLE AND TYRE DIAGNOSTICS

ALIGNMENT ANGLES

ALIGNMENT, PARALLELISM, TANDEM AXLE PARALLELISM & CAMBER

CASTER, TOE-OUT ON TURNS (TURNING RADIUS) & PERIODIC ALIGNMENT CHECKS

TYRE DAMAGE DIAGNOSIS

FEATHER, HEEL AND TOE, SLOPED, CENTRE, WAVY LUMPY & ROUDED WEAR

SHOULDER, TRAMLINE, SHOULDER SECTION, BRAKE SPOT, CROWN IMPACT, DETACHMENT & OF THE CROWN

RUPTURE OF THE CASING PLY, IMPACT / PINCHING, MARBLING, DISLOCATION, BEAD DAMAGE & MULTIPLE CUTS

REGROOVING / RETREADING

MULTI-LIFE TYRES: REAL BENEFITS ON AN EVERYDAY BASIS

WHY REGROOVE?

Regrooving carried out by a professional as per manufacturers recommendations =



+10% more grip and drive ⁽²⁾



up to **-2L/ 100 km** fuel saving



Your operating performance



REGROOVED TYRES

NEW TYRE SAVED



70 kg of raw materials saved ⁽³⁾

Regrooving of truck tyres is authorized by the Motor Vehicle Code and recommended by ETRTO and AFNOR

WHY RETREAD?

Retreading carried out as per recommendations from your manufacturer and service provider =



2x more KILOMETERS ⁽⁴⁾



40% SAVING ON PURCHASE PRICE ⁽⁵⁾



NEW TYRE



RETREADED TYRE

Comparison of raw material consumption ⁽⁶⁾



NEW TYRE

RETREADED TYRE

Waste to recycle **50 kg** less waste to recycle for a retreaded tyre



MULTI-LIFE TYRES: REAL BENEFITS

GENERAL PRINCIPLES OF REGROOVING

WHY REGROOVE?

WHY RETREAD?

MICHELIN, A PARTNER IN SUSTAINABLE MOBILITY

REGROOVING / RETREADING

GENERAL PRINCIPLES ON REGROOVING

- Regrooving involves removing rubber from the layer of existing rubber to restore tread pattern depth.
- Regroovable MICHELIN tyres are marked with the symbol “U” on the sidewall or the word “REGROOVABLE”.
- Regrooving Truck tyres is an operation authorised by country specific laws and recommended by E.T.R.T.O. and A.F.N.O.R. (standard NFR12714) for the safety and increase in performance which it brings about.

WHY REGROOVE?

- **LONGEVITY** - By re-establishing the height of the tyre’s tread pattern again, regrooving extends the mileage of the tyre by **25 % kilometres*** on average
- **FUEL SAVINGS** - Regrooving which is carried out when the tyre has its lowest rolling resistance, also optimises fuel consumption. The potential 25 % extra mileage provided by regrooving is obtained during the period when fuel consumption is at its lowest.
- **BETTER GRIP** – For improved safety. Regrooving re-establishes a deeper tyre tread pattern, giving you better road grip to drive safely. On wet roads, regrooved tyres offer improved transversal grip and approximately 10 % higher traction than the same worn tyres*.
- **ENVIRONMENTAL IMPACT** - Regrooving extends the life of your tyre when it is using the least amount of fuel. This allows you to reduce your CO2 emissions

FOR SAFETY PRECAUTIONS AND Process on REGROOVE, please go to page 99

*MULTI-LIFE TYRES:
REAL BENEFITS*

*GENERAL PRINCIPLES
OF REGROOVING*

WHY REGROOVE?

WHY RETREAD?

*MICHELIN, A PARTNER
IN SUSTAINABLE
MOBILITY*

* Internal Michelin source:
test conducted on polished
concrete.

REGROOVING / RETREADING

WHY RETREAD?

Reduce your running costs

- Reduction in the cost per kilometre.
- Regroovability is assured.
- Excellent retreadability:
 - MICHELIN Recamic retreaded tyres guarantee levels of performance similar to new tyres.
 - Constant regrooving thickness.
- Benefit from our pledge of quality and reliability as MICHELIN Recamic retreading is carried out:
 - Exclusively on MICHELIN casings, the MICHELIN casing is an asset to exploit right down to the last kilometre.
 - With the same materials used for the production of new tyres.



SAFETY PRECAUTIONS AND PROCESS ON RETREAD, PLEASE GO TO PAGE 100

MULTI-LIFE TYRES:
REAL BENEFITS

GENERAL PRINCIPLES
OF REGROOVING

WHY REGROOVE?

WHY RETREAD?

MICHELIN, A PARTNER
IN SUSTAINABLE
MOBILITY

REGROOVING / RETREADING

MICHELIN, A PARTNER COMMITTED TO SUSTAINABLE MOBILITY



Read more in the Michelin Corporate website [HERE](#)

URL: <https://www.michelin.com/en/sustainable-development-mobility/environment/circular-economy/>

Watch the video [HERE](#)

URL: <https://youtu.be/8NnGGTwMgfc>

MULTI-LIFE TYRES: REAL BENEFITS

GENERAL PRINCIPLES OF REGROOVING

WHY REGROOVE?

WHY RETREAD?

MICHELIN, A PARTNER IN SUSTAINABLE MOBILITY

“4R” is our latest incentive to date that will combine sustainable mobility and performance in the long term

*WHY CHOOSE
MICHELIN?*

*TYRE
BASICS*

*CHOOSING THE RIGHT
MICHELIN TYRE*

*MICHELIN TYRES FOR
E2A MARKETS*

*TECHNICAL
CHARACTERISTICS*

*TYRE KNOWLEDGE
AND SAFETY*

*VEHICLES AND
TYRE DIAGNOSTICS*

*REGROOVING /
RETREADING*

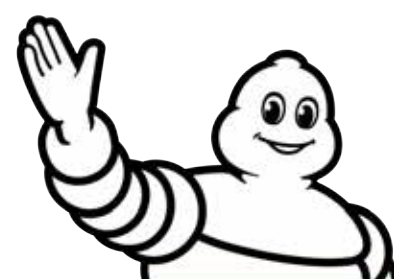

MICHELIN

FOR MORE INFORMATION



MICHELIN TRUCK AND BUS WEBSITE

<https://www.michelin.com.au/michelin-truck-and-bus>



MICHELIN TRUCK AND BUS FACEBOOK

<https://www.facebook.com/michelinaunz>